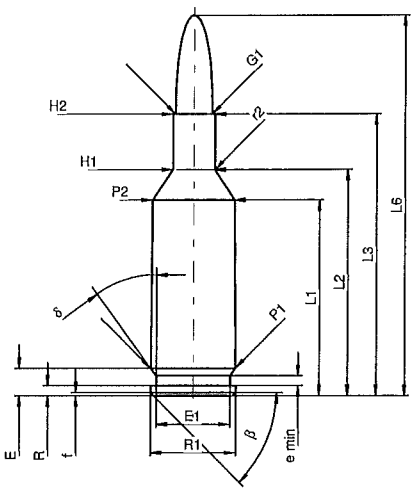
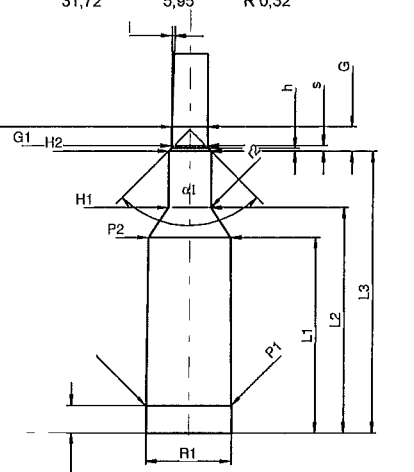
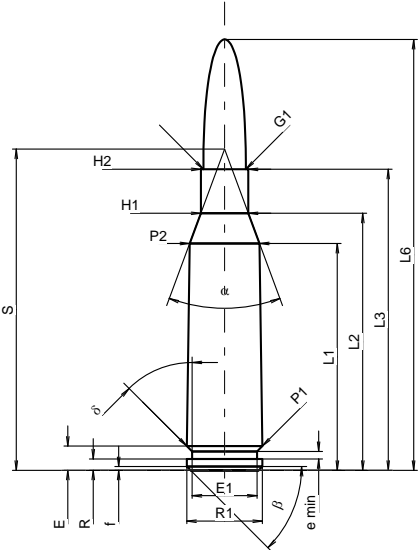
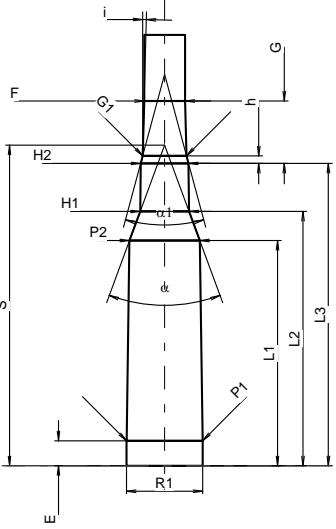
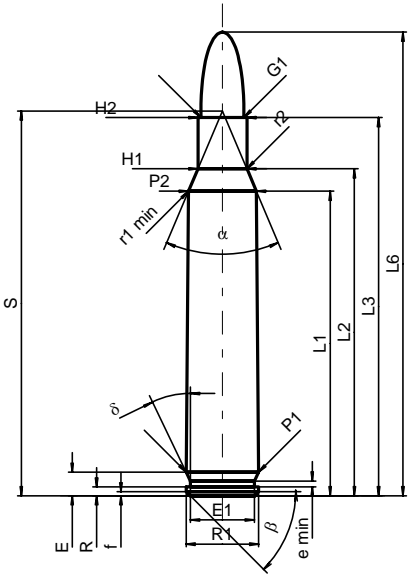
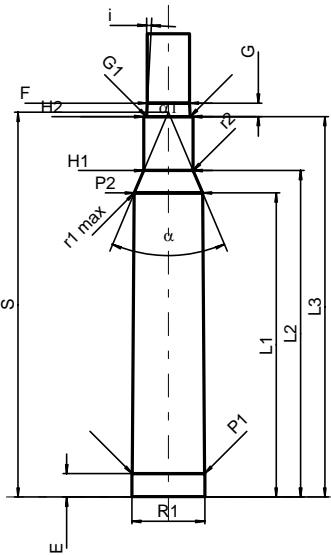

C.I.P.	4,6 x 30		TAB.	I
	Ursprungsland: DE		Datum	04-05-18
			Revision	14-05-20
	<b>PATRONE MAXI</b> <b>Längen</b> L1 <sup>1)*</sup> = 23.02 -0.20 L2 <sup>1)*</sup> = 26.03 -0.20 L3 <sup>1)</sup> = 30.50 L4 = L5 = L6 = 38.50 <b>Hülsenboden</b> R = 1.10 R1 = 8.00 R3 = E = 2.91 E1 = 6.80 e min = 0.75 delta = 30° f = 0.25 beta = 45° <b>Pulverkammer</b> P1 = 8.02 P2 <sup>1)*</sup> = 7.75 -0.20 <b>Schulterkonus</b> alpha = 44°07'37" S = 32.58 r1 min = 1.70 r2 = 2.00 <b>Hülsenhals</b> H1 * = 5.31 H2 <sup>1)</sup> = 5.31 <b>Geschoss</b> G1 <sup>1)</sup> = 4.65 G2 = F = L3+G <sup>1)</sup> = 37.55 <b>Drücke (Energien)</b> <b>Mech. elektr. Wandler</b> Pmax = 4000 bar PK = 4600 bar PE = 5200 bar M = 17.50 EE = 500 Joule <b>Verschiedene Daten</b> Fe <sup>1)3)</sup> = 0.10 delta L = 0.08		<b>PATRONENLAGER MINI</b> <b>Längen</b> L1 * = 22.98 L2 * = 25.85 L3 <sup>1)</sup> = 30.88 <b>Stoßboden</b> R = 3.15 R1 = 8.07 R2 = 3.00 R3 = r = 0.40 <b>Pulverkammer</b> E = 3.60 P1 <sup>1)</sup> = 8.03 P2 * = 7.76 <b>Schulterkonus</b> alpha <sup>1)</sup> = 45°02'28" S = 32.34 r1 max = 1.60 r2 = 2.30 <b>Hülsenhals</b> H1 * = 5.38 H2 <sup>1)</sup> = 5.36 <b>Geschossübergang</b> G1 <sup>1)*</sup> = 4.65 G <sup>1)*</sup> = 7.05 alpha l = 45° h = 0.86 s * = 4.74 i <sup>1)</sup> = 1°36'42" w = <b>Lauf</b> F <sup>1)*</sup> = 4.52 Z <sup>1)</sup> = 4.65 <b>Züge</b> b = 1.21 N = 6 u = 150.00 Q = 16.52 mm <sup>2</sup>	
Maßstab 1.53:1  Maße in << mm >> Maße und Toleranzen für Messläufe siehe Anhang CR-1.	Bemerkungen: 1) Kontrolle aus Sicherheitsgründen 3) Verschlussabstand an Schulter * Grundmaße			

C.I.P.	5 mm /35 SMc		TAB.	I																															
	Ursprungsland: US		Datum	09-05-05																															
			Revision																																
<table border="1"> <thead> <tr> <th>L</th> <th>P</th> <th><math>\alpha</math></th> </tr> </thead> <tbody> <tr><td>27,51</td><td>11,60</td><td>46,36</td></tr> <tr><td>27,99</td><td>11,15</td><td>53,24</td></tr> <tr><td>28,52</td><td>10,62</td><td>58,00</td></tr> <tr><td>29,03</td><td>10,02</td><td>63,38</td></tr> <tr><td>29,54</td><td>9,23</td><td>69,58</td></tr> <tr><td>30,05</td><td>8,60</td><td>76,90</td></tr> <tr><td>30,56</td><td>7,73</td><td>85,86</td></tr> <tr><td>31,06</td><td>6,66</td><td>97,34</td></tr> <tr><td>31,57</td><td>5,97</td><td>105,84</td></tr> <tr><td>31,72</td><td>5,92</td><td>R 0,32</td></tr> </tbody> </table> 	L	P	$\alpha$	27,51	11,60	46,36	27,99	11,15	53,24	28,52	10,62	58,00	29,03	10,02	63,38	29,54	9,23	69,58	30,05	8,60	76,90	30,56	7,73	85,86	31,06	6,66	97,34	31,57	5,97	105,84	31,72	5,92	R 0,32	<p><b>PATRONE MAXI</b></p> <p><b>Längen</b></p> <p>L1 1) = 27.51 -0.20</p> <p>L2 1) = 31.72 -0.20</p> <p>L3 1) = 39.52</p> <p>L4 =</p> <p>L5 =</p> <p>L6 = 53.34</p> <p><b>Hülsenboden</b></p> <p>R = 1.37</p> <p>R1 = 12.01</p> <p>R3 =</p> <p>E = 3.85</p> <p>E1 = 10.39</p> <p>e min = 1.40</p> <p><math>\delta</math> = 36°</p> <p>f = 0.40</p> <p><math>\beta</math> = 45°</p> <p><b>Pulverkammer</b></p> <p>P1 = 11.96</p> <p>P2 1)* = 11.60 -0.20</p> <p><b>Schulterkonus</b></p> <p><math>\alpha</math> =</p> <p>S =</p> <p>r1 min =</p> <p>r2 = 0.32</p> <p><b>Hülsenhals</b></p> <p>H1 * = 5.95</p> <p>H2 1) = 5.94</p> <p><b>Geschoss</b></p> <p>G1 1) = 5.18</p> <p>G2 =</p> <p>F =</p> <p>L3+G 1) = 44.75</p> <p><b>Drücke (Energien)</b></p> <p><b>Mech. elektr. Wandler</b></p> <p>Pmax = 4400 bar</p> <p>PK = 5060 bar</p> <p>PE = 5500 bar</p> <p>M = 17.50</p> <p>EE = 1650 Joule</p> <p><b>Verschiedene Daten</b></p> <p>Fe 1)3) = 0.10</p> <p>delta L =</p>	<p><b>PATRONELAGER MINI</b></p> <p><b>Längen</b></p> <p>L1 = 27.51</p> <p>L2 = 31.72</p> <p>L3 1) = 39.65</p> <p><b>Stoßboden</b></p> <p>R =</p> <p>R1 = 12.04</p> <p>R2 =</p> <p>R3 =</p> <p>r =</p> <p><b>Pulverkammer</b></p> <p>E = 3.85</p> <p>P1 1) = 11.99</p> <p>P2 * = 11.63</p> <p><b>Schulterkonus</b></p> <p><math>\alpha</math> =</p> <p>S =</p> <p>r1 max =</p> <p>r2 = 0.32</p> <p><b>Hülsenhals</b></p> <p>H1 * = 5.97</p> <p>H2 1) = 5.97</p> <p><b>Geschossübergang</b></p> <p>G1 1)* = 5.19</p> <p>G 1) = 3.43</p> <p><math>\alpha</math>1 = 90°</p> <p>h = 0.38</p> <p>s * = 0.76</p> <p>i 1)* = 1°30'</p> <p>w =</p> <p><b>Lauf</b></p> <p>F 1)* = 5.05</p> <p>Z 1) = 5.18</p> <p><b>Züge</b></p> <p>b = 1.30</p> <p>N = 6</p> <p>u = 305.00</p> <p>Q = 20.54 mm<sup>2</sup></p>
L	P	$\alpha$																																	
27,51	11,60	46,36																																	
27,99	11,15	53,24																																	
28,52	10,62	58,00																																	
29,03	10,02	63,38																																	
29,54	9,23	69,58																																	
30,05	8,60	76,90																																	
30,56	7,73	85,86																																	
31,06	6,66	97,34																																	
31,57	5,97	105,84																																	
31,72	5,92	R 0,32																																	
<table border="1"> <thead> <tr> <th>L</th> <th>P</th> <th><math>\alpha</math></th> </tr> </thead> <tbody> <tr><td>27,51</td><td>11,63</td><td>46,36</td></tr> <tr><td>27,99</td><td>11,15</td><td>53,24</td></tr> <tr><td>28,52</td><td>10,62</td><td>58,00</td></tr> <tr><td>29,03</td><td>10,02</td><td>63,38</td></tr> <tr><td>29,54</td><td>9,23</td><td>69,58</td></tr> <tr><td>30,05</td><td>8,60</td><td>76,90</td></tr> <tr><td>30,56</td><td>7,73</td><td>85,86</td></tr> <tr><td>31,06</td><td>6,66</td><td>97,34</td></tr> <tr><td>31,57</td><td>5,97</td><td>105,84</td></tr> <tr><td>31,72</td><td>5,95</td><td>R 0,32</td></tr> </tbody> </table> 	L	P	$\alpha$	27,51	11,63	46,36	27,99	11,15	53,24	28,52	10,62	58,00	29,03	10,02	63,38	29,54	9,23	69,58	30,05	8,60	76,90	30,56	7,73	85,86	31,06	6,66	97,34	31,57	5,97	105,84	31,72	5,95	R 0,32	<p>Maßstab 1:1</p>	<p>Bemerkungen: 1) Kontrolle aus Sicherheitsgründen 3) Verschlussabstand an Schulter * Grundmaße</p>
L	P	$\alpha$																																	
27,51	11,63	46,36																																	
27,99	11,15	53,24																																	
28,52	10,62	58,00																																	
29,03	10,02	63,38																																	
29,54	9,23	69,58																																	
30,05	8,60	76,90																																	
30,56	7,73	85,86																																	
31,06	6,66	97,34																																	
31,57	5,97	105,84																																	
31,72	5,95	R 0,32																																	
<p>Maße in &lt;&lt; mm &gt;&gt; Maße und Toleranzen für Messläufe siehe Anhang CR 1.</p>																																			

<b>C.I.P.</b>	<b>5,45 x 39</b> Ursprungsland: SU	<b>TAB.</b>	<b>I</b>
		<b>Datum</b>	<b>92-07-23</b>
		<b>Revision</b>	<b>15-05-19</b>
	<p><b>PATRONE MAXI</b></p> <p><b>Längen</b></p> <p>L1 <sup>1)</sup> = 30.00 -0.20                  L2 <sup>1)</sup> = 34.00 -0.20                  L3 <sup>1)</sup> = 39.82                  L4 =                  L5 =                  L6 = 57.00</p> <p><b>Hülsenboden</b></p> <p>R = 1.50                  R1 = 10.00                  R3 =                  E = 3.20                  E1 = 8.60                  e min = 1.00                  δ = 45°                  f = 0.50                  β = 45°</p> <p><b>Pulverkammer</b></p> <p>P1 = 10.00                  P2 <sup>1)</sup>* = 9.25 -0.20</p> <p><b>Schulterkonus</b></p> <p>α * = 40°36'32"                  S = 42.50                  r1 min =                  r2 =</p> <p><b>Hülsenhals</b></p> <p>H1 * = 6.29                  H2 <sup>1)</sup> = 6.29</p> <p><b>Geschoss</b></p> <p>G1 <sup>1)</sup> = 5.60                  G2 =                  F =                  L3+G <sup>1)</sup> = 48.08</p> <p><b>Drücke (Energien)</b></p> <p><b>Mech. elektr. Wandler</b></p> <p>Pmax = 3550 bar                  PK = 4083 bar                  PE = 4438 bar                  M = 17.50                  EE = 1800 Joule</p> <p><b>Verschiedene Daten</b></p> <p>Fe <sup>1)3)</sup> = 0.15                  delta L = 0.13</p>	<p><b>PATRONENLAGER MINI</b></p> <p><b>Längen</b></p> <p>L1 = 29.80                  L2 = 33.65                  L3 <sup>1)</sup> = 40.00</p> <p><b>Stoßboden</b></p> <p>R = 1.50                  R1 = 10.10                  R2 =                  R3 =                  r =</p> <p><b>Pulverkammer</b></p> <p>E = 3.30                  P1 <sup>1)</sup> = 10.05                  P2 * = 9.30</p> <p><b>Schulterkonus</b></p> <p>α <sup>1)</sup>* = 40°29'27"                  S * = 42.41                  r1 max =                  r2 =</p> <p><b>Hülsenhals</b></p> <p>H1 * = 6.46                  H2 <sup>1)</sup> = 6.32</p> <p><b>Geschossübergang</b></p> <p>G1 <sup>1)</sup>* = 5.78                  G <sup>1)</sup> = 8.26                  α1 = 30°                  h * = 1.01                  s =                  i <sup>1)</sup>* = 1°30'                  w =</p> <p><b>Lauf</b></p> <p>F <sup>1)</sup>* = 5.40                  Z <sup>1)</sup> = 5.60</p> <p><b>Züge</b></p> <p>b = 2.60                  N = 4                  u * = 195.00                  Q = 23.99 mm<sup>2</sup></p>	
			
<p>Maßstab 1:1</p> <p>Maße in &lt;&lt; mm &gt;&gt; Maße und Toleranzen für Messläufe siehe Anhang CR 1.</p>	<p>Bemerkungen: 1) Kontrolle aus Sicherheitsgründen                  3) Verschlussabstand an Schulter                  * Grundmaße</p>		

<b>C.I.P.</b>	<b>5,6 x 39</b> Ursprungsland: RU	<b>TAB.</b>	<b>I</b>
		<b>Datum</b>	<b>00-02-15</b>
		<b>Revision</b>	<b>07-05-14</b>
	<b>PATRONE MAXI</b>		<b>PATRONENLAGER MINI</b>
	<b>Längen</b> L1 <sup>1)*</sup> = 27.00 -0.20 L2 <sup>1)*</sup> = 32.20 -0.20 L3 <sup>1)</sup> = 38.70 L4 = L5 = L6 = 48.70  <b>Hülsenboden</b> R = 1.50 R1 = 11.35 R3 = E = 3.20 E1 = 9.56 e min = 1.00 δ = 51°58'13" f = β =  <b>Pulverkammer</b> P1 = 11.35 P2 <sup>1)*</sup> = 10.20 -0.20  <b>Schulterkonus</b> α = 41°12'31" S = 40.57 r1 min = 0.50 r2 = 2.00  <b>Hülsenhals</b> H1 * = 6.29 H2 <sup>1)</sup> = 6.29  <b>Geschoss</b> G1 <sup>1)</sup> = 5.67 G2 = F = L3+G <sup>1)</sup> = 49.01  <b>Drücke (Energien)</b> <b>Mech. elektr. Wandler</b> Pmax = 3500 bar PK = 4025 bar PE = 4375 bar M = 17.50 EE = 2100 Joule  <b>Verschiedene Daten</b> Fe <sup>1)3)</sup> = 0.15 delta L = 0.06		<b>Längen</b> L1 * = 26.88 L2 * = 32.22 L3 <sup>1)</sup> = 38.70  <b>Stoßboden</b> R = 1.50 R1 = 11.40 R2 = R3 = r =  <b>Pulverkammer</b> E = 3.50 P1 <sup>1)</sup> = 11.34 P2 * = 10.24  <b>Schulterkonus</b> α <sup>1)</sup> = 39°38'50" S = 41.08 r1 max = 0.50 r2 = 2.50  <b>Hülsenhals</b> H1 * = 6.39 H2 <sup>1)</sup> = 6.29  <b>Geschossübergang</b> G1 <sup>1)*</sup> = 5.78 G <sup>1)*</sup> = 10.31 α1 = 23°59'38" h = 1.20 s * = 6.00 i <sup>1)</sup> = 2°11'33" w =  <b>Lauf</b> F <sup>1)*</sup> = 5.45 Z <sup>1)</sup> = 5.59  <b>Züge</b> b = 2.00 N = 6 u = 420.00 Q = 24.19 mm <sup>2</sup>
Maßstab 1.27:1  Maße in << mm >> Maße und Toleranzen für Messläufe siehe Anhang CR 1.	Bemerkungen: 1) Kontrolle aus Sicherheitsgründen 3) Verschlussabstand an Schulter * Grundmaße		

<b>C.I.P.</b>	<b>5,6 x 50 Mag.</b> Ursprungsland: DE	TAB. <b>I</b>
		Datum <b>84-06-14</b>
		Revision <b>02-05-15</b>
	<b>PATRONE MAXI</b>	<b>PATRONENLAGER MINI</b>
	<p><b>Längen</b></p> <p>L1 <sup>1)</sup>* = 40.26 -0.20                  L2 <sup>1)</sup>* = 43.23 -0.20                  L3 <sup>1)</sup> = 50.00                  L4 =                  L5 =                  L6 = 61.30</p> <p><b>Hülsenboden</b></p> <p>R = 1.14                  R1 = 9.60                  R3 =                  E = 3.10                  E1 = 8.44                  e min = 0.80                  delta = 25°45'                  f = 0.50                  beta = 45°</p> <p><b>Pulverkammer</b></p> <p>P1 = 9.56                  P2 <sup>1)</sup>* = 9.00 -0.20</p> <p><b>Schulterkonus</b></p> <p>alpha = 45°58'38"                  S = 50.87                  r1 min = 0.50                  r2 = 0.50</p> <p><b>Hülsenhals</b></p> <p>H1 * = 6.48                  H2 <sup>1)</sup> = 6.48</p> <p><b>Geschoss</b></p> <p>G1 <sup>1)</sup> = 5.70                  G2 =                  F =                  L3+G <sup>1)</sup> = 51.80</p> <p><b>Drücke (Energien)</b>  <b>Mech. elektr. Wandler</b></p> <p>Pmax = 3800 bar                  PK = 4370 bar                  PE = 4750 bar                  M = 25.00                  EE = 1915 Joule</p> <p><b>Verschiedene Daten</b></p> <p>Fe <sup>1)</sup> = 0.15                  delta L =</p>	<p><b>Längen</b></p> <p>L1 * = 40.22                  L2 * = 43.17                  L3 <sup>1)</sup> = 50.30</p> <p><b>Stoßboden</b></p> <p>R = 1.14                  R1 = 9.64                  R2 =                  R3 =                  r =</p> <p><b>Pulverkammer</b></p> <p>E = 3.10                  P1 <sup>1)</sup> = 9.59                  P2 * = 9.03</p> <p><b>Schulterkonus</b></p> <p>alpha <sup>1)</sup> = 45°55'39"                  S = 50.88                  r1 max = 0.50                  r2 = 0.50</p> <p><b>Hülsenhals</b></p> <p>H1 * = 6.53                  H2 <sup>1)</sup> = 6.51</p> <p><b>Geschossübergang</b></p> <p>G1 <sup>1)</sup>* = 5.74                  G <sup>1)</sup>* = 1.80                  alpha1 = 180°                  h =                  s =                  i <sup>1)</sup> = 2°51'45"                  w =</p> <p><b>Lauf</b></p> <p>F <sup>1)</sup>* = 5.56                  Z <sup>1)</sup> = 5.69</p> <p><b>Züge</b></p> <p>b = 2.00                  N = 6                  u = 350.00                  Q = 25.08 mm<sup>2</sup></p>
	<p><b>Maßstab 1:1</b></p> <p>Maße in &lt;&lt; mm &gt;&gt;                  Maße und Toleranzen für Messläufe                  siehe Anhang CR 1.</p>	<p>Bemerkungen: 1) Kontrolle aus Sicherheitsgründen                  * Grundmaße</p>

<b>C.I.P.</b>	<b>5,6 x 57</b>		<b>TAB.</b>	<b>I</b>
	Ursprungsland: DE		<b>Datum</b>	<b>84-06-14</b>
			<b>Revision</b>	<b>02-05-15</b>
	<b>PATRONE MAXI</b>		<b>PATRONENLAGER MINI</b>	
	<p><b>Längen</b></p> <p>L1 <sup>1)</sup>* = 44.51 -0.20                  L2 <sup>1)</sup>* = 50.41 -0.20                  L3 <sup>1)</sup> = 56.70                  L4 =                  L5 =                  L6 = 69.00</p> <p><b>Hülsenboden</b></p> <p>R = 1.30                  R1 = 11.95                  R3 =                  E = 3.20                  E1 = 10.50                  e min = 1.00                  delta = 37°52'48"                  f = 0.30                  beta = 45°</p> <p><b>Pulverkammer</b></p> <p>P1 = 11.90                  P2 <sup>1)</sup>* = 10.94 -0.20</p> <p><b>Schulterkonus</b></p> <p>alpha = 34°49'06"                  S = 61.95                  r1 min = 0.50                  r2 = 0.50</p> <p><b>Hülsenhals</b></p> <p>H1 * = 7.24                  H2 <sup>1)</sup> = 7.10</p> <p><b>Geschoss</b></p> <p>G1 <sup>1)</sup> = 5.70                  G2 =                  F =                  L3+G <sup>1)</sup> = 67.50</p> <p><b>Drücke (Energien)</b></p> <p><b>Mech. elektr. Wandler</b></p> <p>Pmax = 4400 bar                  PK = 5060 bar                  PE = 5500 bar                  M = 25.00                  EE = 2725 Joule</p> <p><b>Verschiedene Daten</b></p> <p>Fe <sup>1)</sup> = 0.10                  delta L =</p>		<p><b>Längen</b></p> <p>L1 * = 44.46                  L2 * = 50.38                  L3 <sup>1)</sup> = 57.00</p> <p><b>Stoßboden</b></p> <p>R = 1.30                  R1 = 12.00                  R2 =                  R3 =                  r =</p> <p><b>Pulverkammer</b></p> <p>E = 3.20                  P1 <sup>1)</sup> = 11.93                  P2 * = 10.97</p> <p><b>Schulterkonus</b></p> <p>alpha <sup>1)</sup> = 34°47'46"                  S = 61.96                  r1 max = 0.50                  r2 = 0.50</p> <p><b>Hülsenhals</b></p> <p>H1 * = 7.26                  H2 <sup>1)</sup> = 7.12</p> <p><b>Geschossübergang</b></p> <p>G1 <sup>1)</sup>* = 5.72                  G <sup>1)</sup>* = 10.80                  alpha1 = 180°                  h =                  s =                  i <sup>1)</sup> = 0°28'39"                  w =</p> <p><b>Lauf</b></p> <p>F <sup>1)</sup>* = 5.54                  Z <sup>1)</sup> = 5.69</p> <p><b>Züge</b></p> <p>b = 2.00                  N = 6                  u = 250.00                  Q = 25.03 mm<sup>2</sup></p>	
<p>Maßstab 1:1</p> <p>Maße in &lt;&lt; mm &gt;&gt;                  Maße und Toleranzen für Messläufe                  siehe Anhang CR 1.</p>		<p>Bemerkungen: 1) Kontrolle aus Sicherheitsgründen                  * Grundmaße</p>		

<b>C.I.P.</b>	<b>5,6 x 61 SE.v.H.</b>		<b>TAB.</b>	<b>I</b>
	Ursprungsland: DE		Datum	84-06-14
			Revision	08-09-23
	<b>PATRONE MAXI</b>		<b>PATRONENLAGER MINI</b>	
	<p><b>Längen</b></p> <p>L1 <sup>1)</sup>* = 44.01 -0.20</p> <p>L2 <sup>1)</sup>* = 53.06 -0.20</p> <p>L3 <sup>1)</sup> = 61.00</p> <p>L4 =</p> <p>L5 =</p> <p>L6 = 80.00</p> <p><b>Hülsenboden</b></p> <p>R = 1.50</p> <p>R1 = 12.20</p> <p>R3 =</p> <p>E = 3.00</p> <p>E1 = 10.50</p> <p>e min = 1.00</p> <p>δ = 59°31'48"</p> <p>f = 0.30</p> <p>β = 45°</p> <p><b>Pulverkammer</b></p> <p>P1 = 12.20</p> <p>P2 <sup>1)</sup>* = 11.60 -0.20</p> <p><b>Schulterkonus</b></p> <p>α = 30°00'02"</p> <p>S = 65.66</p> <p>r1 min = 0.50</p> <p>r2 = 0.50</p> <p><b>Hülsenhals</b></p> <p>H1 * = 6.75</p> <p>H2 <sup>1)</sup> = 6.68</p> <p><b>Geschoss</b></p> <p>G1 <sup>1)</sup> = 5.79</p> <p>G2 =</p> <p>F =</p> <p>L3+G <sup>1)</sup> = 75.50</p> <p><b>Drücke (Energien)</b></p> <p><b>Mech. elektr. Wandler</b></p> <p>Pmax = 4400 bar</p> <p>PK = 5060 bar</p> <p>PE = 5500 bar</p> <p>M = 25.00</p> <p>EE = 3005 Joule</p> <p><b>Verschiedene Daten</b></p> <p>Fe <sup>1)3)</sup> = 0.10</p> <p>delta L =</p>		<p><b>Längen</b></p> <p>L1 * = 43.96</p> <p>L2 * = 53.01</p> <p>L3 <sup>1)</sup> = 61.30</p> <p><b>Stoßboden</b></p> <p>R = 1.50</p> <p>R1 = 12.25</p> <p>R2 =</p> <p>R3 =</p> <p>r =</p> <p><b>Pulverkammer</b></p> <p>E = 3.00</p> <p>P1 <sup>1)</sup> = 12.23</p> <p>P2 * = 11.63</p> <p><b>Schulterkonus</b></p> <p>α <sup>1)</sup> = 30°00'02"</p> <p>S = 65.66</p> <p>r1 max = 0.50</p> <p>r2 = 0.50</p> <p><b>Hülsenhals</b></p> <p>H1 * = 6.78</p> <p>H2 <sup>1)</sup> = 6.71</p> <p><b>Geschossübergang</b></p> <p>G1 <sup>1)</sup>* = 5.87</p> <p>G <sup>1)</sup>* = 14.50</p> <p>α1 = 180°</p> <p>h =</p> <p>s =</p> <p>i <sup>1)</sup> = 0°34'22"</p> <p>w =</p> <p><b>Lauf</b></p> <p>F <sup>1)</sup>* = 5.58</p> <p>Z <sup>1)</sup> = 5.76</p> <p><b>Züge</b></p> <p>b = 2.00</p> <p>N = 6</p> <p>u = 220.00</p> <p>Q = 25.56 mm<sup>2</sup></p>	
<p>Maßstab 1:1.05</p> <p>Maße in &lt;&lt; mm &gt;&gt;</p> <p>Maße und Toleranzen für Messläufe siehe Anhang CR 1.</p>			<p>Bemerkungen: 1) Kontrolle aus Sicherheitsgründen 3) Verschlussabstand an Schulter * Grundmaße</p>	

<b>C.I.P.</b>	<b>5,7 x 28</b>		<b>TAB.</b>	<b>I</b>
	Ursprungsland: BE		<b>Datum</b>	<b>93-10-19</b>
			<b>Revision</b>	<b>02-05-15</b>
	<b>PATRONE MAXI</b>		<b>PATRONENLAGER MINI</b>	
	<p><b>Längen</b></p> <p>L1 <sup>1)</sup>* = 23.15 -0.20</p> <p>L2 <sup>1)</sup>* = 24.27 -0.20</p> <p>L3 <sup>1)</sup> = 28.90</p> <p>L4 =</p> <p>L5 = 31.44</p> <p>L6 = 40.50</p> <p><b>Hülsenboden</b></p> <p>R = 1.14</p> <p>R1 = 7.80</p> <p>R3 =</p> <p>E = 3.38</p> <p>E1 = 6.60</p> <p>e min = 0.79</p> <p>δ = 25°</p> <p>f = 0.28</p> <p>β = 45°</p> <p><b>Pulverkammer</b></p> <p>P1 = 7.95</p> <p>P2 <sup>1)</sup>* = 7.95 -0.20</p> <p><b>Schulterkonus</b></p> <p>α = 70°03'10"</p> <p>S = 28.82</p> <p>r1 min =</p> <p>r2 = 1.00</p> <p><b>Hülsenhals</b></p> <p>H1 * = 6.38</p> <p>H2 <sup>1)</sup> = 6.38</p> <p><b>Geschoss</b></p> <p>G1 <sup>1)</sup> = 5.70</p> <p>G2 = 5.26</p> <p>F =</p> <p>L3+G <sup>1)</sup> = 35.35</p> <p><b>Drücke (Energien)</b></p> <p><b>Mech. elektr. Wandler</b></p> <p>Pmax = 3450 bar</p> <p>PK = 3968 bar</p> <p>PE = 4313 bar</p> <p>M = 12.00</p> <p>EE = 1500 Joule</p> <p><b>Verschiedene Daten</b></p> <p>Fe <sup>1)3)</sup> = 0.15</p> <p>delta L = 0.08</p>		<p><b>Längen</b></p> <p>L1 * = 23.03</p> <p>L2 * = 24.18</p> <p>L3 <sup>1)</sup> = 29.03</p> <p><b>Stoßboden</b></p> <p>R = 3.02</p> <p>R1 = 8.00</p> <p>R2 = 2.90</p> <p>R3 =</p> <p>r =</p> <p><b>Pulverkammer</b></p> <p>E = 3.52</p> <p>P1 <sup>1)</sup> = 8.00</p> <p>P2 * = 8.00</p> <p><b>Schulterkonus</b></p> <p>α <sup>1)</sup> = 69°59'02"</p> <p>S = 28.74</p> <p>r1 max =</p> <p>r2 =</p> <p><b>Hülsenhals</b></p> <p>H1 * = 6.39</p> <p>H2 <sup>1)</sup> = 6.39</p> <p><b>Geschossübergang</b></p> <p>G1 <sup>1)</sup>* = 5.75</p> <p>G <sup>1)</sup>* = 6.45</p> <p>α1 = 90°</p> <p>h * = 0.32</p> <p>s =</p> <p>i <sup>1)</sup> = 1°01'41"</p> <p>w =</p> <p><b>Lauf</b></p> <p>F <sup>1)</sup>* = 5.53</p> <p>Z <sup>1)</sup> = 5.62</p> <p><b>Züge</b></p> <p>b = 1.63</p> <p>N = 8</p> <p>u = 228.60</p> <p>Q = 24.61 mm<sup>2</sup></p>	
<p>Maßstab 1.54:1</p> <p>Maße in &lt;&lt; mm &gt;&gt;</p> <p>Maße und Toleranzen für Messläufe siehe Anhang CR 1.</p>			<p>Bemerkungen: 1) Kontrolle aus Sicherheitsgründen 3) Verschlussabstand an Schulter * Grundmaße</p>	

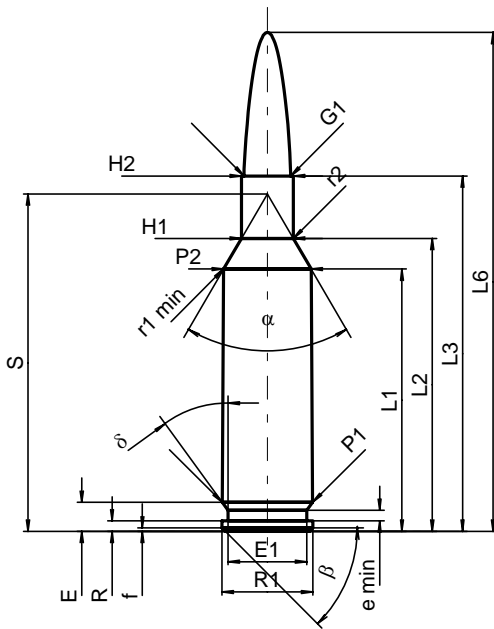
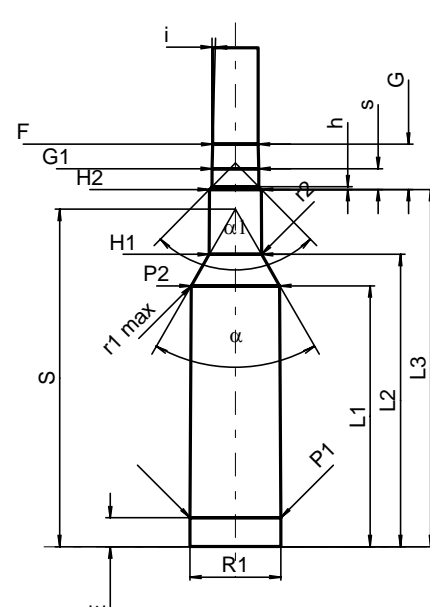

<b>C.I.P.</b>	<b>6 x 47 ATZL</b>		<b>TAB.</b>	<b>I</b>
	Ursprungsland: AT		Datum	97-11-05
			Revision	11-05-25
	<b>PATRONE MAXI</b>		<b>PATRONENLAGER MINI</b>	
	<p><b>Längen</b></p> <p>L1 <sup>1)*</sup> = 37.08 -0.20                  L2 <sup>1)*</sup> = 39.93 -0.20                  L3 <sup>1)</sup> = 47.00                  L4 =                  L5 =                  L6 = 63.00</p> <p><b>Hülsenboden</b></p> <p>R = 1.14                  R1 = 9.60                  R3 =                  E = 3.11                  E1 = 8.43                  e min = 0.76                  delta = 25°                  f = 0.45                  beta = 35°</p> <p><b>Pulverkammer</b></p> <p>P1 = 9.56                  P2 <sup>1)*</sup> = 9.07 -0.20</p> <p><b>Schulterkonus</b></p> <p>alpha * = 46°00'30"                  S * = 47.76                  r1 min = 0.64                  r2 = 2.54</p> <p><b>Hülsenhals</b></p> <p>H1 * = 6.65                  H2 <sup>1)</sup> = 6.65</p> <p><b>Geschoss</b></p> <p>G1 <sup>1)</sup> = 6.17                  G2 =                  F =                  L3+G <sup>1)</sup> = 52.57</p> <p><b>Drücke (Energien)</b></p> <p><b>Mech. elektr. Wandler</b></p> <p>Pmax = 4050 bar                  PK = 4660 bar                  PE = 5060 bar                  M = 25.00                  EE = 2100 Joule</p> <p><b>Verschiedene Daten</b></p> <p>Fe <sup>1)3)</sup> = 0.10                  delta L =</p>		<p><b>Längen</b></p> <p>L1 * = 37.07                  L2 * = 39.95                  L3 <sup>1)</sup> = 47.30</p> <p><b>Stoßboden</b></p> <p>R =                  R1 = 9.63                  R2 =                  R3 =                  r =</p> <p><b>Pulverkammer</b></p> <p>E = 3.11                  P1 <sup>1)</sup> = 9.59                  P2 * = 9.09</p> <p><b>Schulterkonus</b></p> <p>alpha <sup>1)</sup> = 45°54'58"                  S = 47.80                  r1 max = 0.64                  r2 = 3.18</p> <p><b>Hülsenhals</b></p> <p>H1 * = 6.65                  H2 <sup>1)</sup> = 6.65</p> <p><b>Geschossübergang</b></p> <p>G1 <sup>1)*</sup> = 6.18                  G <sup>1)*</sup> = 5.57                  alpha1 = 90°                  h = 0.24                  s * = 2.52                  i <sup>1)</sup> = 1°30'9"                  w =</p> <p><b>Lauf</b></p> <p>F <sup>1)*</sup> = 6.02                  Z <sup>1)</sup> = 6.17</p> <p><b>Züge</b></p> <p>b = 2.29                  N = 6                  u = 356.00                  Q = 29.52 mm<sup>2</sup></p>	
<p>Maßstab 1.29:1</p> <p>Maße in &lt;&lt; mm &gt;&gt;                  Maße und Toleranzen für Messläufe                  siehe Anhang CR 1.</p>		<p>Bemerkungen: 1) Kontrolle aus Sicherheitsgründen                  3) Verschlussabstand an Schulter                  * Grundmaße</p>		

C.I.P.	6 x 47 SM		TAB.	I
	Ursprungsland: CH		Datum	02-01-22
			Revision	02-05-15
	<b>PATRONE MAXI</b> <b>Längen</b> L1 <sup>1)</sup> = 34.69 -0.20 L2 <sup>1)</sup> = 38.74 -0.20 L3 <sup>1)</sup> = 47.00 L4 = L5 = L6 = 66.00 <b>Hülsenboden</b> R = 1.37 R1 = 12.01 R3 = E = 3.85 E1 = 10.39 e min = 1.40 delta = 36° f = 0.45 beta = 45° <b>Pulverkammer</b> P1 = 11.96 P2 <sup>1)*</sup> = 11.59 -0.20 <b>Schulterkonus</b> alpha* = 60°30' S* = 44.63 r1 min = 1.50 r2 = 1.50 <b>Hülsenhals</b> H1* = 6.87 H2 <sup>1)</sup> = 6.87 <b>Geschoss</b> G1 <sup>1)</sup> = 6.18 G2 = F = L3+G <sup>1)</sup> = 52.98 <b>Drücke (Energien)</b> <b>Mech. elektr. Wandler</b> Pmax = 3900 bar PK = 4485 bar PE = 4875 bar M = 25.00 EE = 2730 Joule <b>Verschiedene Daten</b> Fe <sup>1)</sup> = 0.10 delta L = 0.08		<b>PATRONE MINIM</b> <b>Längen</b> L1 = 34.51 L2 = 38.66 L3 <sup>1)</sup> = 47.26 <b>Stoßboden</b> R = R1 = 12.04 R2 = R3 = r = <b>Pulverkammer</b> E = 3.85 P1 <sup>1)</sup> = 11.99 P2* = 11.70 <b>Schulterkonus</b> alpha <sup>1)*</sup> = 60° S* = 44.64 r1 max = 0.64 r2 = 1.91 <b>Hülsenhals</b> H1* = 6.91 H2 <sup>1)</sup> = 6.88 <b>Geschossübergang</b> G1 <sup>1)*</sup> = 6.19 G <sup>1)</sup> = 5.98 alpha1 = 89°10'32" h = 0.35 s* = 2.74 i <sup>1)*</sup> = 1°35'24" w = <b>Lauf</b> F <sup>1)*</sup> = 6.01 Z <sup>1)</sup> = 6.17 <b>Züge</b> b = 2.15 N = 6 u = 205.00 Q = 29.42 mm <sup>2</sup>	
		Maßstab 1:1  Maße in << mm >> Maße und Toleranzen für Messläufe siehe Anhang CR 1.		Bemerkungen: 1) Kontrolle aus Sicherheitsgründen * Grundmaße

<b>C.I.P.</b>	<b>6 x 51 ATZL</b>		<b>TAB.</b>	<b>I</b>
	Ursprungsland: AT		<b>Datum</b>	<b>97-11-05</b>
			<b>Revision</b>	<b>02-05-15</b>
	<b>PATRONE MAXI</b>		<b>PATRONENLAGER MINI</b>	
	<p><b>Längen</b></p> <p>L1 <sup>1)</sup>* = 40.27 -0.20</p> <p>L2 <sup>1)</sup>* = 43.03 -0.20</p> <p>L3 <sup>1)</sup> = 51.00</p> <p>L4 =</p> <p>L5 =</p> <p>L6 = 68.00</p> <p><b>Hülsenboden</b></p> <p>R = 1.14</p> <p>R1 = 9.60</p> <p>R3 =</p> <p>E = 3.10</p> <p>E1 = 8.44</p> <p>e min = 0.80</p> <p>delta = 25°46'09"</p> <p>f = 0.50</p> <p>beta = 45°</p> <p><b>Pulverkammer</b></p> <p>P1 = 9.56</p> <p>P2 <sup>1)</sup>* = 9.00 -0.20</p> <p><b>Schulterkonus</b></p> <p>alpha = 46°07'17"</p> <p>S = 50.84</p> <p>r1 min = 0.50</p> <p>r2 = 0.50</p> <p><b>Hülsenhals</b></p> <p>H1 * = 6.65</p> <p>H2 <sup>1)</sup> = 6.65</p> <p><b>Geschoss</b></p> <p>G1 <sup>1)</sup> = 6.17</p> <p>G2 =</p> <p>F =</p> <p>L3+G <sup>1)</sup> = 56.57</p> <p><b>Drücke (Energien)</b></p> <p><b>Mech. elektr. Wandler</b></p> <p>Pmax = 4050 bar</p> <p>PK = 4658 bar</p> <p>PE = 5060 bar</p> <p>M = 25.00</p> <p>EE = 2100 Joule</p> <p><b>Verschiedene Daten</b></p> <p>Fe <sup>1)</sup> = 0.10</p> <p>delta L =</p>		<p><b>Längen</b></p> <p>L1 * = 40.22</p> <p>L2 * = 43.02</p> <p>L3 <sup>1)</sup> = 51.30</p> <p><b>Stoßboden</b></p> <p>R = 1.14</p> <p>R1 = 9.64</p> <p>R2 =</p> <p>R3 =</p> <p>r =</p> <p><b>Pulverkammer</b></p> <p>E = 3.11</p> <p>P1 <sup>1)</sup> = 9.59</p> <p>P2 * = 9.03</p> <p><b>Schulterkonus</b></p> <p>alpha <sup>1)</sup> = 46°03'04"</p> <p>S = 50.84</p> <p>r1 max = 0.50</p> <p>r2 = 0.50</p> <p><b>Hülsenhals</b></p> <p>H1 * = 6.65</p> <p>H2 <sup>1)</sup> = 6.65</p> <p><b>Geschossübergang</b></p> <p>G1 <sup>1)</sup>* = 6.18</p> <p>G <sup>1)</sup>* = 5.57</p> <p>alpha1 = 90°</p> <p>h = 0.23</p> <p>s = 2.52</p> <p>i <sup>1)</sup> = 1°30'09"</p> <p>w =</p> <p><b>Lauf</b></p> <p>F <sup>1)</sup>* = 6.02</p> <p>Z <sup>1)</sup> = 6.17</p> <p><b>Züge</b></p> <p>b = 2.29</p> <p>N = 6</p> <p>u = 356.00</p> <p>Q = 29.52 mm<sup>2</sup></p>	
	<p>Maßstab 1:1</p> <p>Maße in &lt;&lt; mm &gt;&gt;</p> <p>Maße und Toleranzen für Messläufe siehe Anhang CR 1.</p>		<p>Bemerkungen: 1) Kontrolle aus Sicherheitsgründen * Grundmaße</p>	

<b>C.I.P.</b>	<b>6 x 62 Freres</b>		<b>TAB.</b>	<b>I</b>
	Ursprungsland: DE		Datum	84-06-14
			Revision	05-02-25
	<b>PATRONE MAXI</b>		<b>PATRONENLAGER MINI</b>	
	<p><b>Längen</b></p> <p>L1 <sup>1)</sup>* = 49.40 -0.20                  L2 <sup>1)</sup>* = 55.75 -0.20                  L3 <sup>1)</sup> = 61.75                  L4 =                  L5 =                  L6 = 82.00</p> <p><b>Hülsenboden</b></p> <p>R = 1.30                  R1 = 12.10                  R3 =                  E = 3.20                  E1 = 10.50                  e min = 1.00                  delta = 41°37'48"                  f = 0.30                  beta = 45°</p> <p><b>Pulverkammer</b></p> <p>P1 = 12.10                  P2 <sup>1)</sup>* = 11.53 -0.20</p> <p><b>Schulterkonus</b></p> <p>alpha = 39°58'51"                  S = 65.25                  r1 min = 0.50                  r2 = 0.50</p> <p><b>Hülsenhals</b></p> <p>H1* = 6.91                  H2 <sup>1)</sup> = 6.91</p> <p><b>Geschoss</b></p> <p>G1 <sup>1)</sup> = 6.18                  G2 =                  F =                  L3+G <sup>1)</sup> = 68.42</p> <p><b>Drücke (Energien)</b></p> <p><b>Mech. elektr. Wandler</b></p> <p>Pmax = 4300 bar                  PK = 4945 bar                  PE = 5375 bar                  M = 25.00                  EE = 3300 Joule</p> <p><b>Verschiedene Daten</b></p> <p>Fe <sup>1)</sup> = 0.10                  delta L = 0.12</p>		<p><b>Längen</b></p> <p>L1* = 49.26                  L2* = 55.58                  L3 <sup>1)</sup> = 62.00</p> <p><b>Stoßboden</b></p> <p>R = 1.30                  R1 = 12.12                  R2 =                  R3 =                  r =</p> <p><b>Pulverkammer</b></p> <p>E = 3.20                  P1 <sup>1)</sup> = 12.12                  P2* = 11.55</p> <p><b>Schulterkonus</b></p> <p>alpha <sup>1)</sup> = 39°59'43"                  S = 65.13                  r1 max = 0.50                  r2 = 0.50</p> <p><b>Hülsenhals</b></p> <p>H1* = 6.95                  H2 <sup>1)</sup> = 6.93</p> <p><b>Geschossübergang</b></p> <p>G1 <sup>1)</sup>* = 6.19                  G <sup>1)</sup>* = 6.67                  alpha1 = 180°                  h =                  s* = 2.97                  i <sup>1)</sup> = 1°19'                  w =</p> <p><b>Lauf</b></p> <p>F <sup>1)</sup>* = 6.02                  Z <sup>1)</sup> = 6.17</p> <p><b>Züge</b></p> <p>b = 1.73                  N = 6                  u = 260.00                  Q = 29.25 mm<sup>2</sup></p>	
Maßstab 1:1				
Maße in << mm >> Maße und Toleranzen für Messläufe siehe Anhang CR 1.		Bemerkungen: 1) Kontrolle aus Sicherheitsgründen * Grundmaße		

C.I.P.	6 mm BR Farè	TAB.	I
		Datum	15-05-19
		Revision	
Ursprungsland: IT			
	<b>PATRONE MAXI</b>		<b>PATRONENLAGER MINI</b>
	<b>Längen</b> L1 <sup>1)</sup> = 30.31 -0.20 L2 <sup>1)</sup> = 33.17 -0.20 L3 <sup>1)</sup> = 39.24 L4 = L5 = L6 = 62.00  <b>Hülsenboden</b> R = 1.37 R1 = 11.97 R3 = E = 3.83 E1 = 10.39 e min = 1.40 δ = 36° f = 0.40 β = 45°  <b>Pulverkammer</b> P1 = 11.93 P2 <sup>1)</sup> * = 11.64 -0.20  <b>Schulterkonus</b> α * = 80°14'19" S * = 37.22 r1 min = 0.25 r2 = 1.50  <b>Hülsenhals</b> H1 * = 6.82 H2 <sup>1)</sup> = 6.82  <b>Geschoss</b> G1 <sup>1)</sup> = 6.17 G2 = F = L3+G <sup>1)</sup> = 46.03  <b>Drücke (Energien)</b> <b>Mech. elektr. Wandler</b> Pmax = 4400 bar PK = 5060 bar PE = 5500 bar M = 17.50 EE = 2545 Joule  <b>Verschiedene Daten</b> Fe <sup>1)3)</sup> = 0.10 delta L =	<b>Längen</b> L1 = 30.41 L2 = 33.27 L3 <sup>1)</sup> = 39.50  <b>Stoßboden</b> R = R1 = 12.00 R2 = R3 = r =  <b>Pulverkammer</b> E = 3.85 P1 <sup>1)</sup> = 11.96 P2 * = 11.67  <b>Schulterkonus</b> α <sup>1)</sup> * = 80°00'14" S * = 37.36 r1 max = 0.25 r2 = 1.50  <b>Hülsenhals</b> H1 * = 6.87 H2 <sup>1)</sup> = 6.87  <b>Geschossübergang</b> G1 <sup>1)</sup> * = 6.18 G <sup>1)</sup> = 6.79 α1 = 90° h = 0.35 s * = 3.64 i <sup>1)</sup> * = 1°27'17" w =  <b>Lauf</b> F <sup>1)</sup> * = 6.02 Z <sup>1)</sup> = 6.17  <b>Züge</b> b = 2.29 N = 6 u * = 203.20 Q = 29.52 mm <sup>2</sup>	
<p>Maßstab 1:1</p> <p>Maße in &lt;&lt; mm &gt;&gt; Maße und Toleranzen für Messläufe siehe Anhang CR1.</p>		<p>Bemerkungen: 1) Kontrolle aus Sicherheitsgründen 3) Verschlussabstand an Schulter * Grundmaße</p>	

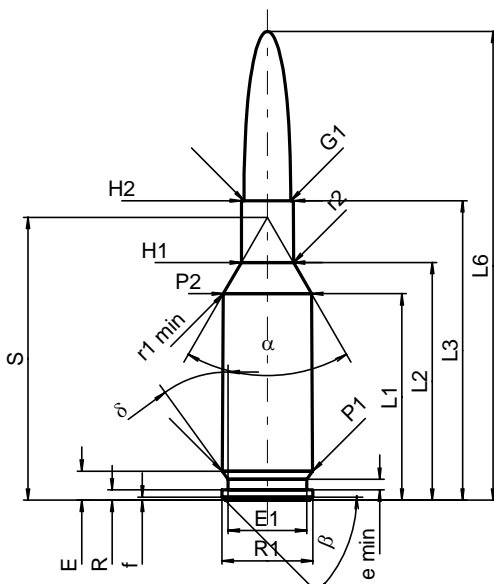
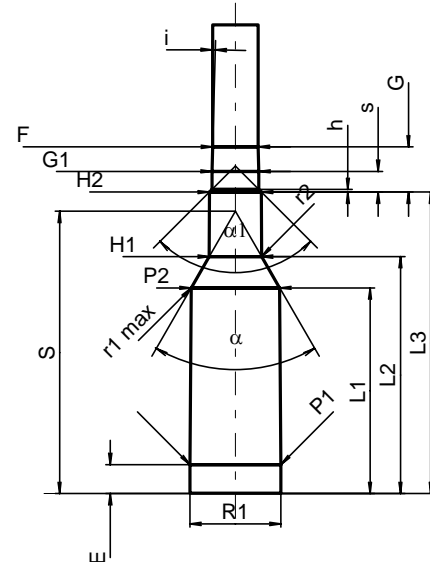
<b>C.I.P.</b>	<b>6mm BR Norma</b>  Ursprungsland: SE	TAB. <b>I</b>
		Datum <b>95-12-20</b>
		Revision <b>02-05-15</b>
	<b>PATRONE MAXI</b>	<b>PATRONENLAGER MINI</b>
	<p><b>Längen</b></p> <p>L1<sup>1)</sup> = 27.30 -0.20                  L2<sup>1)</sup> = 31.44 -0.20                  L3<sup>1)</sup> = 39.62                  L4 =                  L5 =                  L6 = 62.00</p> <p><b>Hülsenboden</b></p> <p>R = 1.37                  R1 = 12.01                  R3 =                  E = 3.85                  E1 = 10.39                  e min = 1.40                  δ = 36°                  f = 0.40                  β = 45°</p> <p><b>Pulverkammer</b></p> <p>P1 = 11.96                  P2<sup>1)*</sup> = 11.68 -0.20</p> <p><b>Schulterkonus</b></p> <p>α* = 60°                  S* = 37.42                  r1 min = 0.64                  r2 = 1.50</p> <p><b>Hülsenhals</b></p> <p>H1* = 6.90                  H2<sup>1)</sup> = 6.87</p> <p><b>Geschoss</b></p> <p>G1<sup>1)</sup> = 6.18                  G2 =                  F =                  L3+G<sup>1)</sup> = 45.61</p> <p><b>Drücke (Energien)</b> <b>Mech. elektr. Wandler</b></p> <p>Pmax = 4050 bar                  PK = 4658 bar                  PE = 5060 bar                  M = 17.50                  EE = 2545 Joule</p> <p><b>Verschiedene Daten</b></p> <p>Fe<sup>1)</sup> = 0.10                  delta L = 0.07</p>	<p><b>Längen</b></p> <p>L1 = 27.20                  L2 = 31.36                  L3<sup>1)</sup> = 39.88</p> <p><b>Stoßboden</b></p> <p>R =                  R1 = 12.04                  R2 =                  R3 =                  r =</p> <p><b>Pulverkammer</b></p> <p>E = 3.85                  P1<sup>1)</sup> = 11.99                  P2* = 11.71</p> <p><b>Schulterkonus</b></p> <p>α<sup>1)*</sup> = 60°                  S* = 37.34                  r1 max = 0.64                  r2 = 1.91</p> <p><b>Hülsenhals</b></p> <p>H1* = 6.91                  H2<sup>1)</sup> = 6.88</p> <p><b>Geschossübergang</b></p> <p>G1<sup>1)*</sup> = 6.19                  G<sup>1)</sup> = 5.98                  α1 = 90°                  h = 0.35                  s* = 2.74                  i<sup>1)*</sup> = 1°30'                  w =</p> <p><b>Lauf</b></p> <p>F<sup>1)*</sup> = 6.02                  Z<sup>1)</sup> = 6.17</p> <p><b>Züge</b></p> <p>b = 2.29                  N = 6                  u = 203.20                  Q = 29.52 mm<sup>2</sup></p>
		
Maßstab 1:1		
Maße in << mm >> Maße und Toleranzen für Messläufe siehe Anhang CR 1.	Bemerkungen: 1) Kontrolle aus Sicherheitsgründen * Grundmaße	

<b>C.I.P.</b>	<b>6 mm BR Rem.</b>		TAB.	I
	Ursprungsland: US		Datum	94-03-01
			Revision	02-05-15
	<b>PATRONE MAXI</b>		<b>PATRONENLAGER MINI</b>	
	<p><b>Längen</b></p> <p>L1 <sup>1)</sup> = 27.30 -0.20                  L2 <sup>1)</sup> = 31.44 -0.20                  L3 <sup>1)</sup> = 39.62                  L4 =                  L5 =                  L6 = 55.88</p> <p><b>Hülsenboden</b></p> <p>R = 1.37                  R1 = 12.01                  R3 =                  E = 3.85                  E1 = 10.39                  e min = 1.40                  delta = 36°                  f = 0.46                  beta = 35°</p> <p><b>Pulverkammer</b></p> <p>P1 = 11.96                  P2 <sup>1)</sup>* = 11.68 -0.20</p> <p><b>Schulterkonus</b></p> <p>alpha * = 60°                  S * = 37.42                  r1 min = 0.64                  r2 = 1.27</p> <p><b>Hülsenhals</b></p> <p>H1 * = 6.90                  H2 <sup>1)</sup> = 6.87</p> <p><b>Geschoss</b></p> <p>G1 <sup>1)</sup> = 6.18                  G2 =                  F =                  L3+G <sup>1)</sup> = 44.44</p> <p><b>Drücke (Energien)</b>  <b>Mech. elektr. Wandler</b></p> <p>Pmax = 4050 bar                  PK = 4658 bar                  PE = 5060 bar                  M = 17.50                  EE = 2525 Joule</p> <p><b>Verschiedene Daten</b></p> <p>Fe <sup>1)</sup> = 0.10                  delta L = 0.07</p>		<p><b>Längen</b></p> <p>L1 = 27.20                  L2 = 31.36                  L3 <sup>1)</sup> = 39.88</p> <p><b>Stoßboden</b></p> <p>R =                  R1 = 12.04                  R2 =                  R3 =                  r =</p> <p><b>Pulverkammer</b></p> <p>E = 3.85                  P1 <sup>1)</sup> = 11.99                  P2 * = 11.71</p> <p><b>Schulterkonus</b></p> <p>alpha <sup>1)</sup>* = 60°                  S * = 37.34                  r1 max = 0.64                  r2 = 1.91</p> <p><b>Hülsenhals</b></p> <p>H1 * = 6.91                  H2 <sup>1)</sup> = 6.88</p> <p><b>Geschossübergang</b></p> <p>G1 <sup>1)</sup>* = 6.19                  G <sup>1)</sup> = 4.82                  alpha 1 * = 90°                  h = 0.35                  s = 3.20                  i <sup>1)</sup>* = 3°                  w =</p> <p><b>Lauf</b></p> <p>F <sup>1)</sup>* = 6.02                  Z <sup>1)</sup> = 6.17</p> <p><b>Züge</b></p> <p>b = 2.29                  N = 6                  u = 228.60                  Q = 29.52 mm<sup>2</sup></p>	
Maßstab 1:1				
Maße in << mm >> Maße und Toleranzen für Messläufe siehe Anhang CR 1.		Bemerkungen: 1) Kontrolle aus Sicherheitsgründen * Grundmaße		

C.I.P.	6 mm D.B.G. Ursprungsland: IT	TAB.	I
		Datum	16-05-18
		Revision	
	<p><b>PATRONE MAXI</b></p> <p><b>Längen</b></p> <p>L1 <sup>1)</sup> = 32.82 -0.20                  L2 <sup>1)</sup> = 35.91 -0.20                  L3 <sup>1)</sup> = 41.00                  L4 =                  L5 =                  L6 = 58.00</p> <p><b>Hülsenboden</b></p> <p>R = 1.24                  R1 = 10.72                  R3 =                  E = 3.15                  E1 = 9.09                  e min = 0.84                  delta = 36°                  f = 0.38                  beta = 35°</p> <p><b>Pulverkammer</b></p> <p>P1 = 10.65                  P2 <sup>1)</sup>* = 10.34 -0.20</p> <p><b>Schulterkonus</b></p> <p>alpha * = 60°                  S * = 41.77                  r1 min =                  r2 =</p> <p><b>Hülsenhals</b></p> <p>H1 * = 6.77                  H2 <sup>1)</sup> = 6.77</p> <p><b>Geschoss</b></p> <p>G1 <sup>1)</sup> = 6.17                  G2 =                  F =                  L3+G <sup>1)</sup> = 44.84</p> <p><b>Drücke (Energien)</b></p> <p><b>Mech. elektr. Wandler</b></p> <p>Pmax = 4150 bar                  PK = 4773 bar                  PE = 5188 bar                  M = 25.00                  EE = 2100 Joule</p> <p><b>Verschiedene Daten</b></p> <p>Fe <sup>1)3)</sup> = 0.10                  delta L =</p>	<p><b>PATRONENLAGER MINI</b></p> <p><b>Längen</b></p> <p>L1 = 32.91                  L2 = 36.02                  L3 <sup>1)</sup> = 41.23</p> <p><b>Stoßboden</b></p> <p>R =                  R1 = 10.80                  R2 =                  R3 =                  r =</p> <p><b>Pulverkammer</b></p> <p>E = 3.18                  P1 <sup>1)</sup> = 10.68                  P2 * = 10.37</p> <p><b>Schulterkonus</b></p> <p>alpha <sup>1)</sup>* = 60°                  S * = 41.89                  r1 max =                  r2 =</p> <p><b>Hülsenhals</b></p> <p>H1 * = 6.78                  H2 <sup>1)</sup> = 6.78</p> <p><b>Geschossübergang</b></p> <p>G1 <sup>1)</sup>* = 6.18                  G <sup>1)</sup> = 3.84                  alpha 1 = 90°                  h = 0.30                  s * = 0.32                  i <sup>1)</sup>* = 1°18'07"                  w =</p> <p><b>Lauf</b></p> <p>F <sup>1)</sup>* = 6.02                  Z <sup>1)</sup> = 6.17</p> <p><b>Züge</b></p> <p>b = 1.73                  N = 6                  u = 254.00                  Q = 29.25 mm<sup>2</sup></p>	

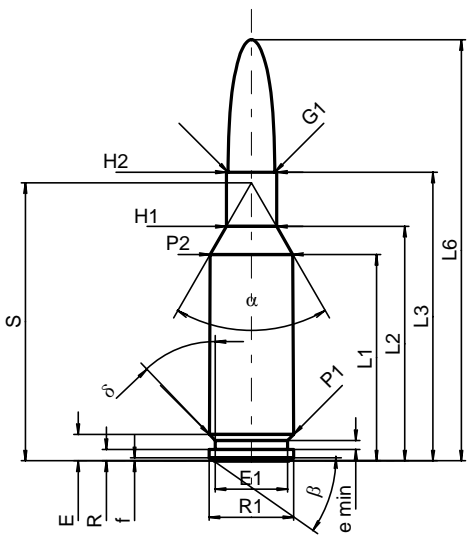
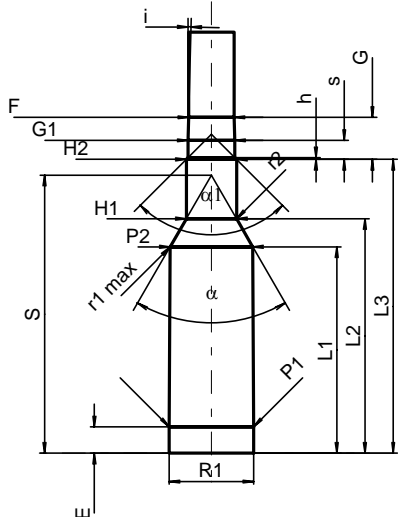

<b>C.I.P.</b>	<b>6 mm PPC</b>		<b>TAB. I</b>
	Ursprungsland: US		<b>Datum 84-06-14</b>
			<b>Revision 02-05-15</b>
	<b>PATRONE MAXI</b>		<b>PATRONENLAGER MINI</b>
	<p><b>Längen</b></p> <p>L1<sup>1)</sup> = 27.30 -0.20                  L2<sup>1)</sup> = 31.00 -0.20                  L3<sup>1)</sup> = 38.18                  L4 =                  L5 =                  L6 = 55.70</p> <p><b>Hülsenboden</b></p> <p>R = 1.50                  R1 = 11.18                  R3 =                  E = 3.50                  E1 = 9.60                  e min = 1.20                  delta = 43°43'12"                  f = 0.40                  beta = 35°</p> <p><b>Pulverkammer</b></p> <p>P1 = 11.13                  P2<sup>1)*</sup> = 10.92 -0.20</p> <p><b>Schulterkonus</b></p> <p>alpha* = 60°                  S* = 36.76                  r1 min =                  r2 =</p> <p><b>Hülsenhals</b></p> <p>H1* = 6.65                  H2<sup>1)</sup> = 6.65</p> <p><b>Geschoss</b></p> <p>G1<sup>1)</sup> = 6.17                  G2 =                  F =                  L3+G<sup>1)</sup> = 43.76</p> <p><b>Drücke (Energien)</b></p> <p><b>Mech. elektr. Wandler</b></p> <p>Pmax = 4050 bar                  PK = 4658 bar                  PE = 5060 bar                  M = 17.50                  EE = 2250 Joule</p> <p><b>Verschiedene Daten</b></p> <p>Fe<sup>1)</sup> = 0.10                  delta L =</p>		<p><b>Längen</b></p> <p>L1 = 27.30                  L2 = 31.02                  L3<sup>1)</sup> = 38.86</p> <p><b>Stoßboden</b></p> <p>R =                  R1 = 11.20                  R2 =                  R3 =                  r =</p> <p><b>Pulverkammer</b></p> <p>E = 3.50                  P1<sup>1)</sup> = 11.17                  P2* = 10.95</p> <p><b>Schulterkonus</b></p> <p>alpha<sup>1)*</sup> = 60°                  S* = 36.78                  r1 max = 1.52                  r2 = 1.52</p> <p><b>Hülsenhals</b></p> <p>H1* = 6.65                  H2<sup>1)</sup> = 6.65</p> <p><b>Geschossübergang</b></p> <p>G1<sup>1)*</sup> = 6.18                  G<sup>1)</sup> = 5.58                  alpha1* = 90°                  h = 0.24                  s = 2.52                  i<sup>1)*</sup> = 1°30'                  w =</p> <p><b>Lauf</b></p> <p>F<sup>1)*</sup> = 6.02                  Z<sup>1)</sup> = 6.17</p> <p><b>Züge</b></p> <p>b = 2.29                  N = 6                  u = 551.00                  Q = 29.52 mm<sup>2</sup></p>
			
Maßstab 1:1			
Maße in << mm >> Maße und Toleranzen für Messläufe siehe Anhang CR 1.	Bemerkungen: 1) Kontrolle aus Sicherheitsgründen * Grundmaße		

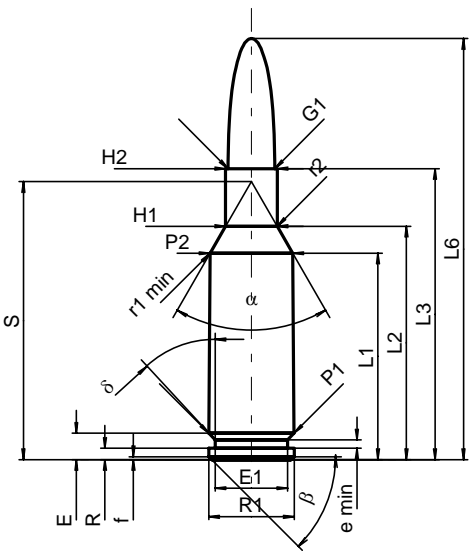
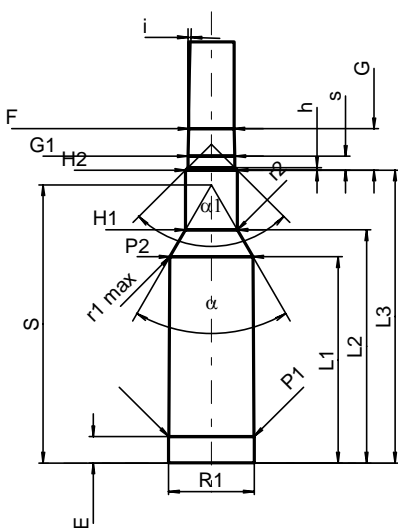

<b>C.I.P.</b>	<b>6 mm PPC-USA</b>  Ursprungsland: FI	TAB. <b>I</b>
		Datum <b>89-04-18</b>
		Revision <b>02-05-15</b>
	<b>PATRONE MAXI</b>	<b>PATRONENLAGER MINI</b>
	<p><b>Längen</b></p> <p>L1 <sup>1)</sup>* = 27.30 -0.20                  L2 <sup>1)</sup>* = 30.87 -0.20                  L3 <sup>1)</sup> = 38.48                  L4 =                  L5 =                  L6 = 55.70</p> <p><b>Hülsenboden</b></p> <p>R = 1.50                  R1 = 11.30                  R3 =                  E = 3.50                  E1 = 9.60                  e min = 1.10                  delta = 42°43'12"                  f = 0.40                  beta = 45°</p> <p><b>Pulverkammer</b></p> <p>P1 = 11.26                  P2 <sup>1)</sup>* = 10.95 -0.20</p> <p><b>Schulterkonus</b></p> <p>alpha = 60°05'34"                  S = 36.77                  r1 min = 1.00                  r2 = 3.00</p> <p><b>Hülsenhals</b></p> <p>H1 * = 6.82                  H2 <sup>1)</sup> = 6.82</p> <p><b>Geschoss</b></p> <p>G1 <sup>1)</sup> = 6.17                  G2 =                  F =                  L3+G <sup>1)</sup> = 43.96</p> <p><b>Drücke (Energien)</b>  <b>Mech. elektr. Wandler</b></p> <p>Pmax = 4050 bar                  PK = 4658 bar                  PE = 5060 bar                  M = 17.50                  EE = 2020 Joule</p> <p><b>Verschiedene Daten</b></p> <p>Fe <sup>1)</sup> = 0.10                  delta L =</p>	<p><b>Längen</b></p> <p>L1 * = 27.27                  L2 * = 30.84                  L3 <sup>1)</sup> = 38.74</p> <p><b>Stoßboden</b></p> <p>R =                  R1 = 11.32                  R2 =                  R3 =                  r =</p> <p><b>Pulverkammer</b></p> <p>E = 3.50                  P1 <sup>1)</sup> = 11.28                  P2 * = 10.98</p> <p><b>Schulterkonus</b></p> <p>alpha <sup>1)</sup> = 59°58'21"                  S = 36.78                  r1 max = 0.50                  r2 = 3.00</p> <p><b>Hülsenhals</b></p> <p>H1 * = 6.86                  H2 <sup>1)</sup> = 6.85</p> <p><b>Geschossübergang</b></p> <p>G1 <sup>1)</sup>* = 6.19                  G <sup>1)</sup>* = 5.48                  alpha1 = 90°                  h = 0.33                  s * = 1.85                  i <sup>1)</sup> = 1°30'                  w =</p> <p><b>Lauf</b></p> <p>F <sup>1)</sup>* = 6.00                  Z <sup>1)</sup> = 6.14</p> <p><b>Züge</b></p> <p>b = 2.28                  N = 6                  u = 305.00                  Q = 29.26 mm<sup>2</sup></p>
		
Maßstab 1:1		
Maße in << mm >> Maße und Toleranzen für Messläufe siehe Anhang CR 1.	Bemerkungen: 1) Kontrolle aus Sicherheitsgründen * Grundmaße	

<b>C.I.P.</b>	<b>6 mm Rem. (244 Rem.)</b>	TAB.	I
		Datum	84-06-14
		Revision	02-05-15
Ursprungsland: US			
	<b>PATRONE MAXI</b>	<b>PATRONENLAGER MINI</b>	
	<p><b>Längen</b></p> <p>L1<sup>1)</sup> = 43.81 -0.20                  L2<sup>1)</sup> = 47.81 -0.20                  L3<sup>1)</sup> = 56.72                  L4 =                  L5 =                  L6 = 71.76</p> <p><b>Hülsenboden</b></p> <p>R = 1.24                  R1 = 12.01                  R3 =                  E = 3.40                  E1 = 10.36                  e min = 0.94                  delta = 34°                  f = 0.38                  beta = 35°</p> <p><b>Pulverkammer</b></p> <p>P1 = 12.01                  P2<sup>1)*</sup> = 10.91 -0.20</p> <p><b>Schulterkonus</b></p> <p>alpha* = 52°                  S* = 55.00                  r1 min = 0.64                  r2 = 2.54</p> <p><b>Hülsenhals</b></p> <p>H1* = 7.01                  H2<sup>1)</sup> = 7.01</p> <p><b>Geschoss</b></p> <p>G1<sup>1)</sup> = 6.18                  G2 =                  F =                  L3+G<sup>1)</sup> = 61.24</p> <p><b>Drücke (Energien)</b></p> <p><b>Mech. elektr. Wandler</b></p> <p>Pmax = 4300 bar                  PK = 4945 bar                  PE = 5375 bar                  M = 25.00                  EE = 3180 Joule</p> <p><b>Verschiedene Daten</b></p> <p>Fe<sup>1)</sup> = 0.10                  delta L = 0.10</p>	<p><b>Längen</b></p> <p>L1 = 43.66                  L2 = 47.66                  L3<sup>1)</sup> = 57.25</p> <p><b>Stoßboden</b></p> <p>R =                  R1 = 12.14                  R2 =                  R3 =                  r =</p> <p><b>Pulverkammer</b></p> <p>E = 3.40                  P1<sup>1)</sup> = 12.04                  P2* = 10.96</p> <p><b>Schulterkonus</b></p> <p>alpha<sup>1)*</sup> = 52°                  S* = 54.90                  r1 max = 0.64                  r2 = 3.18</p> <p><b>Hülsenhals</b></p> <p>H1* = 7.06                  H2<sup>1)</sup> = 7.04</p> <p><b>Geschossübergang</b></p> <p>G1<sup>1)*</sup> = 6.19                  G<sup>1)</sup> = 4.52                  alpha1* = 90°                  h = 0.43                  s = 3.00                  i<sup>1)*</sup> = 3°                  w =</p> <p><b>Lauf</b></p> <p>F<sup>1)*</sup> = 6.02                  Z<sup>1)</sup> = 6.17</p> <p><b>Züge</b></p> <p>b = 2.29                  N = 6                  u = 228.60                  Q = 29.48 mm<sup>2</sup></p>	
Maßstab 1:1			
Maße in << mm >> Maße und Toleranzen für Messläufe siehe Anhang CR 1.		Bemerkungen: 1) Kontrolle aus Sicherheitsgründen * Grundmaße	

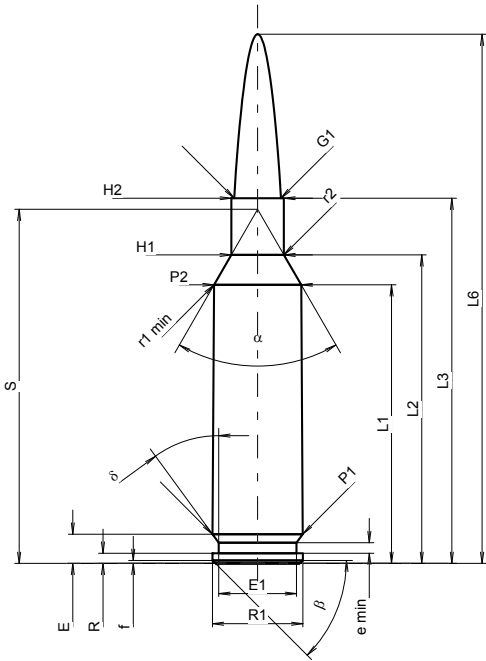
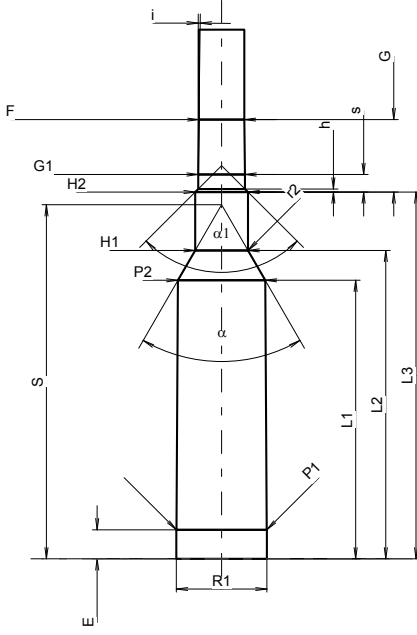
<b>C.I.P.</b>	<b>6 XC</b>		TAB.	I
	Ursprungsland: SE		Datum	08-04-15
			Revision	
	<b>PATRONE MAXI</b>		<b>PATRONENLAGER MINI</b>	
	<p><b>Längen</b></p> <p>L1 <sup>1)</sup> = 36.85 -0.20                  L2 <sup>1)</sup> = 40.81 -0.20                  L3 <sup>1)</sup> = 48.30                  L4 =                  L5 =                  L6 = 70.00</p> <p><b>Hülsenboden</b></p> <p>R = 1.35                  R1 = 11.95                  R3 =                  E = 3.86                  E1 = 10.30                  e min = 1.40                  δ = 36°                  f = 0.40                  β = 45°</p> <p><b>Pulverkammer</b></p> <p>P1 = 11.92                  P2 <sup>1)</sup>* = 11.53 -0.20</p> <p><b>Schulterkonus</b></p> <p>α * = 60°                  S * = 46.84                  r1 min = 1.00                  r2 = 1.50</p> <p><b>Hülsenhals</b></p> <p>H1 * = 6.96                  H2 <sup>1)</sup> = 6.96</p> <p><b>Geschoss</b></p> <p>G1 <sup>1)</sup> = 6.18                  G2 =                  F =                  L3+G <sup>1)</sup> = 57.87</p> <p><b>Drücke (Energien)</b></p> <p><b>Mech. elektr. Wandler</b></p> <p>Pmax = 4400 bar                  PK = 5060 bar                  PE = 5500 bar                  M = 25.00                  EE = 3080 Joule</p> <p><b>Verschiedene Daten</b></p> <p>Fe <sup>1)3)</sup> = 0.10                  delta L =</p>		<p><b>Längen</b></p> <p>L1 = 36.85                  L2 = 40.81                  L3 <sup>1)</sup> = 48.54</p> <p><b>Stoßboden</b></p> <p>R =                  R1 = 11.98                  R2 =                  R3 =                  r =</p> <p><b>Pulverkammer</b></p> <p>E = 3.83                  P1 <sup>1)</sup> = 11.94                  P2 * = 11.56</p> <p><b>Schulterkonus</b></p> <p>α <sup>1)</sup>* = 60°                  S * = 46.86                  r1 max =                  r2 = 1.52</p> <p><b>Hülsenhals</b></p> <p>H1 * = 6.98                  H2 <sup>1)</sup> = 6.98</p> <p><b>Geschossübergang</b></p> <p>G1 <sup>1)</sup>* = 6.19                  G <sup>1)</sup> = 9.57                  α1 * = 90°                  h = 0.39                  s = 2.31                  i <sup>1)</sup>* = 0°45'                  w =</p> <p><b>Lauf</b></p> <p>F <sup>1)</sup>* = 6.00                  Z <sup>1)</sup> = 6.20</p> <p><b>Züge</b></p> <p>b = 2.29                  N = 4                  u = 203.20                  Q = 29.21 mm<sup>2</sup></p>	
				
Maßstab 1:1  Maße in << mm >> Maße und Toleranzen für Messläufe siehe Anhang CR 1.		Bemerkungen: 1) Kontrolle aus Sicherheitsgründen 3) Verschlussabstand an Schulter * Grundmaße		



C.I.P.	6,5 - 284 Norma	TAB.	I
		Datum	00-02-15
		Revision	08-04-15
Ursprungsland: SE			
	<b>PATRONE MAXI</b>		<b>PATRONENLAGER MINI</b>
	<p><b>Längen</b></p> <p>L1 <sup>1)</sup> = 44.98 -0.20                  L2 <sup>1)</sup> = 48.20 -0.20                  L3 <sup>1)</sup> = 55.12                  L4 =                  L5 =                  L6 = 82.00</p> <p><b>Hülsenboden</b></p> <p>R = 1.37                  R1 = 12.01                  R3 =                  E = 3.78                  E1 = 10.39                  e min = 1.02                  delta = 40°                  f = 0.35                  beta = 45°</p> <p><b>Pulverkammer</b></p> <p>P1 = 12.72                  P2 <sup>1)</sup>* = 12.06 -0.20</p> <p><b>Schulterkonus</b></p> <p>alpha * = 70°14'46"                  S * = 53.55                  r1 min = 0.76                  r2 = 3.18</p> <p><b>Hülsenhals</b></p> <p>H1 * = 7.53                  H2 <sup>1)</sup> = 7.53</p> <p><b>Geschoss</b></p> <p>G1 <sup>1)</sup> = 6.71                  G2 =                  F =                  L3+G <sup>1)</sup> = 67.34</p> <p><b>Drücke (Energien)</b></p> <p><b>Mech. elektr. Wandler</b></p> <p>Pmax = 4100 bar                  PK = 4715 bar                  PE = 5125 bar                  M = 25.00                  EE = 3200 Joule</p> <p><b>Verschiedene Daten</b></p> <p>Fe <sup>1)3)</sup> = 0.10                  delta L =</p>		<p><b>Längen</b></p> <p>L1 = 44.96                  L2 = 48.18                  L3 <sup>1)</sup> = 55.37</p> <p><b>Stoßboden</b></p> <p>R =                  R1 = 12.81                  R2 =                  R3 =                  r =</p> <p><b>Pulverkammer</b></p> <p>E = 3.78                  P1 <sup>1)</sup> = 12.75                  P2 * = 12.09</p> <p><b>Schulterkonus</b></p> <p>alpha <sup>1)</sup>* = 70°                  S * = 53.59                  r1 max = 0.76                  r2 = 3.18</p> <p><b>Hülsenhals</b></p> <p>H1 * = 7.58                  H2 <sup>1)</sup> = 7.55</p> <p><b>Geschossübergang</b></p> <p>G1 <sup>1)</sup>* = 6.72                  G <sup>1)</sup> = 12.22                  alpha 1 * = 90°                  h = 0.42                  s = 8.02                  i <sup>1)</sup> = 1°30'                  w =</p> <p><b>Lauf</b></p> <p>F <sup>1)</sup>* = 6.50                  Z <sup>1)</sup> = 6.71</p> <p><b>Züge</b></p> <p>b = 2.29                  N = 6                  u = 228.60                  Q = 34.66 mm<sup>2</sup></p>
Maßstab 1:1.0			
Maße in << mm >> Maße und Toleranzen für Messläufe siehe Anhang CR 1.		Bemerkungen: 1) Kontrolle aus Sicherheitsgründen 3) Verschlussabstand an Schulter * Grundmaße	

C.I.P.	6,5 x 39		TAB.	I
	Ursprungsland: RU		Datum	13-05-22
			Revision	
	<b>PATRONE MAXI</b>		<b>PATRONENLAGER MINI</b>	
	<p><b>Längen</b></p> <p>L1 <sup>1)</sup> = 30.50 -0.20                      L2 <sup>1)</sup> = 32.81 -0.20                      L3 <sup>1)</sup> = 39.00                      L4 =                      L5 =                      L6 = 56.00</p> <p><b>Hülsenboden</b></p> <p>R = 1.50                      R1 = 11.35                      R3 =                      E = 3.20                      E1 = 9.56                      e min = 1.00                      delta = 52°                      f = 0.25                      beta = 45°</p> <p><b>Pulverkammer</b></p> <p>P1 = 11.35                      P2 <sup>1)</sup>* = 10.07 -0.20</p> <p><b>Schulterkonus</b></p> <p>alpha * = 60°                      S * = 39.22                      r1 min = 1.00                      r2 = 1.50</p> <p><b>Hülsenhals</b></p> <p>H1 * = 7.40                      H2 <sup>1)</sup> = 7.40</p> <p><b>Geschoss</b></p> <p>G1 <sup>1)</sup> = 6.70                      G2 =                      F =                      L3+G <sup>1)</sup> = 46.35</p> <p><b>Drücke (Energien)</b></p> <p><b>Mech. elektr. Wandler</b></p> <p>Pmax = 4100 bar                      PK = 4715 bar                      PE = 5125 bar                      M = 25.00                      EE = 2500 Joule</p> <p><b>Verschiedene Daten</b></p> <p>Fe <sup>1)3)</sup> = 0.10                      delta L = 0.22</p>		<p><b>Längen</b></p> <p>L1 = 30.24                      L2 = 32.54                      L3 <sup>1)</sup> = 41.00</p> <p><b>Stoßboden</b></p> <p>R = 1.50                      R1 = 11.37                      R2 =                      R3 =                      r =</p> <p><b>Pulverkammer</b></p> <p>E = 3.50                      P1 <sup>1)</sup> = 11.36                      P2 * = 10.12</p> <p><b>Schulterkonus</b></p> <p>alpha <sup>1)</sup>* = 60°                      S * = 39.00                      r1 max = 0.50                      r2 = 1.50</p> <p><b>Hülsenhals</b></p> <p>H1 * = 7.46                      H2 <sup>1)</sup> = 7.40</p> <p><b>Geschossübergang</b></p> <p>G1 <sup>1)</sup>* = 7.40                      G <sup>1)</sup> = 7.35                      alpha l =                      h =                      s =                      i <sup>1)</sup>* = 3°30'12"                      w =</p> <p><b>Lauf</b></p> <p>F <sup>1)</sup>* = 6.50                      Z <sup>1)</sup> = 6.70</p> <p><b>Züge</b></p> <p>b = 2.50                      N = 4                      u = 250.00                      Q = 34.21 mm<sup>2</sup></p>	
<p>Maßstab 1.19:1</p> <p>Maße in &lt;&lt; mm &gt;&gt; Maße und Toleranzen für Messläufe siehe Anhang CR 1.</p>	<p>Bemerkungen: 1) Kontrolle aus Sicherheitsgründen 3) Verschlussabstand an Schulter * Grundmaße</p>			

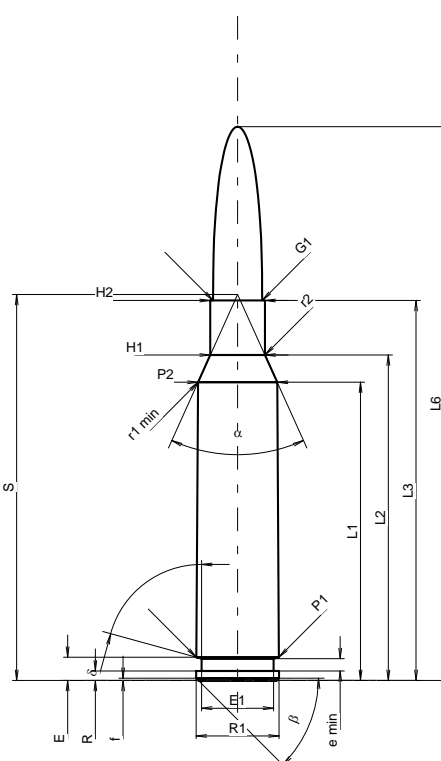
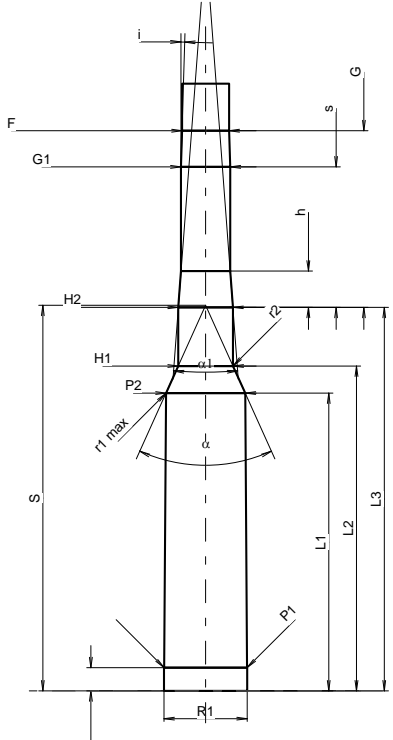

C.I.P.	6,5 x 47 Lapua	TAB.	I
		Datum	06-05-16
		Revision	14-05-20
Ursprungsland: FI			
	<b>PATRONE MAXI</b>		<b>PATRONENLAGER MINI</b>
	<b>Längen</b> L1 <sup>1)</sup> = 35.68 -0.20 L2 <sup>1)</sup> = 39.31 -0.20 L3 <sup>1)</sup> = 47.00 L4 = L5 = L6 = 71.00 <b>Hülsenboden</b> R = 1.37 R1 = 12.01 R3 = E = 3.85 E1 = 10.39 e min = 1.40 δ = 36° f = 0.38 β = 45° <b>Pulverkammer</b> P1 = 11.95 P2 <sup>1)</sup> * = 11.59 -0.20 <b>Schulterkonus</b> α * = 60° S * = 45.72 r1 min = 1.00 r2 = 1.50 <b>Hülsenhals</b> H1 * = 7.40 H2 <sup>1)</sup> = 7.40 <b>Geschoss</b> G1 <sup>1)</sup> * = 6.71 G2 = F = L3+G <sup>1)</sup> = 55.70 <b>Drücke (Energien)</b> <b>Mech. elektr. Wandler</b> Pmax = 4350 bar PK = 5003 bar PE = 5438 bar M = 25.00 EE = 3300 Joule <b>Verschiedene Daten</b> Fe <sup>1)3)</sup> = 0.10 delta L = 0.08	<b>Längen</b> L1 = 35.57 L2 = 39.19 L3 <sup>1)</sup> = 47.26 <b>Stoßboden</b> R = R1 = 12.04 R2 = R3 = r = <b>Pulverkammer</b> E = 3.85 P1 <sup>1)</sup> = 11.99 P2 * = 11.63 <b>Schulterkonus</b> α <sup>1)</sup> * = 60° S * = 45.64 r1 max = 0.75 r2 = 1.75 <b>Hülsenhals</b> H1 * = 7.45 H2 <sup>1)</sup> = 7.42 <b>Geschossübergang</b> G1 <sup>1)</sup> * = 6.72 G = 8.70 α1 = 90° h = 0.35 s * = 4.50 i <sup>1)</sup> * = 1°30' w = <b>Lauf</b> F <sup>1)</sup> * = 6.50 Z <sup>1)</sup> = 6.70 <b>Züge</b> b = 2.29 N = 6 u = 200.00 Q = 34.59 mm <sup>2</sup>	
Maßstab 1.14:1  Maße in << mm >> Maße und Toleranzen für Messläufe siehe Anhang CR 1.		Bemerkungen: 1) Kontrolle aus Sicherheitsgründen 3) Verschlussabstand an Schulter * Grundmaße	

C.I.P.	6,5 x 52 Carcano		TAB.	I
			Datum	93-09-21
	Ursprungsland: IT		Revision	14-05-20
	<b>PATRONE MAXI</b>		<b>PATRONENLAGER MINI</b>	
	<b>Längen</b> L1 <sup>1)*</sup> = 41.20 -0.20 L2 <sup>1)*</sup> = 44.96 -0.20 L3 <sup>1)</sup> = 52.50 L4 = L5 = L6 = 76.50  <b>Hülsenboden</b> R = 1.30 R1 = 11.45 R3 = E = 3.20 E1 = 9.95 e min = 1.70 δ = 74°40'48" f = 0.30 β = 45°  <b>Pulverkammer</b>  P1 = 11.41 P2 <sup>1)*</sup> = 10.94 -0.20  <b>Schulterkonus</b> α = 48°31'53" S = 53.33 r1 min = 3.00 r2 = 2.25  <b>Hülsenhals</b> H1 * = 7.55 H2 <sup>1)</sup> = 7.55  <b>Geschoss</b> G1 <sup>1)</sup> = 6.80 G2 = F = L3+G <sup>1)</sup> = 76.90  <b>Drücke (Energien)</b> <b>Mech. elektr. Wandler</b> Pmax = 2850 bar PK = 3278 bar PE = 3560 bar M = 25.00 EE = 2465 Joule  <b>Verschiedene Daten</b> Fe <sup>1)3)</sup> = 0.15 delta L = 0.05		<b>Längen</b> L1 * = 41.15 L2 * = 44.89 L3 <sup>1)</sup> = 53.00  <b>Stoßboden</b> R = R1 = 11.50 R2 = R3 = r =  <b>Pulverkammer</b> E = 3.20 P1 <sup>1)</sup> = 11.46 P2 * = 10.95  <b>Schulterkonus</b> α <sup>1)</sup> = 48°38'1" S = 53.27 r1 max = 3.00 r2 = 2.25  <b>Hülsenhals</b> H1 * = 7.57 H2 <sup>1)</sup> = 7.55  <b>Geschossübergang</b> G1 <sup>1)*</sup> = 6.80 G <sup>1)*</sup> = 24.40 α1 = 8°34'41" h = 5.00 s * = 19.40 i <sup>1)</sup> = 1°43'6" w =  <b>Lauf</b> F <sup>1)*</sup> = 6.50 Z <sup>1)</sup> = 6.80  <b>Züge</b> b = 3.00 N = 4 u = 201.50 Q = 35.05 mm <sup>2</sup>	
	Maßstab 1:1.04  Maße in << mm >> Maße und Toleranzen für Messläufe siehe Anhang CR 1.		Bemerkungen: 1) Kontrolle aus Sicherheitsgründen 3) Verschlussabstand an Schulter * Grundmaße	

<b>C.I.P.</b>	<b>6,5 x 54 Mauser</b>		<b>TAB.</b>	<b>I</b>
	Ursprungsland: DE		<b>Datum</b>	<b>84-06-14</b>
			<b>Revision</b>	<b>02-05-15</b>
	<b>PATRONE MAXI</b>		<b>PATRONENLAGER MINI</b>	
	<p><b>Längen</b></p> <p>L1 <sup>1)</sup>* = 36.50 -0.20</p> <p>L2 <sup>1)</sup>* = 43.05 -0.20</p> <p>L3 <sup>1)</sup> = 54.00</p> <p>L4 =</p> <p>L5 =</p> <p>L6 = 68.00</p> <p><b>Hülsenboden</b></p> <p>R = 1.50</p> <p>R1 = 11.80</p> <p>R3 =</p> <p>E = 3.60</p> <p>E1 = 10.20</p> <p>e min = 1.00</p> <p>δ = 38°30'</p> <p>f = 0.30</p> <p>β = 45°</p> <p><b>Pulverkammer</b></p> <p>P1 = 11.95</p> <p>P2 <sup>1)</sup>* = 11.10 -0.20</p> <p><b>Schulterkonus</b></p> <p>α = 29°59'56"</p> <p>S = 57.21</p> <p>r1 min = 0.50</p> <p>r2 = 0.50</p> <p><b>Hülsenhals</b></p> <p>H1 * = 7.59</p> <p>H2 <sup>1)</sup> = 7.59</p> <p><b>Geschoss</b></p> <p>G1 <sup>1)</sup> = 6.64</p> <p>G2 =</p> <p>F =</p> <p>L3+G <sup>1)</sup> = 68.00</p> <p><b>Drücke (Energien)</b></p> <p><b>Mech. elektr. Wandler</b></p> <p>Pmax = 3050 bar</p> <p>PK = 3508 bar</p> <p>PE = 3810 bar</p> <p>M = 25.00</p> <p>EE = 2380 Joule</p> <p><b>Verschiedene Daten</b></p> <p>Fe <sup>1)</sup> = 0.15</p> <p>delta L =</p>		<p><b>Längen</b></p> <p>L1 * = 36.44</p> <p>L2 * = 42.99</p> <p>L3 <sup>1)</sup> = 54.30</p> <p><b>Stoßboden</b></p> <p>R = 1.50</p> <p>R1 = 11.85</p> <p>R2 =</p> <p>R3 =</p> <p>r =</p> <p><b>Pulverkammer</b></p> <p>E = 3.60</p> <p>P1 <sup>1)</sup> = 11.98</p> <p>P2 * = 11.13</p> <p><b>Schulterkonus</b></p> <p>α <sup>1)</sup> = 29°59'56"</p> <p>S = 57.21</p> <p>r1 max = 0.50</p> <p>r2 = 0.50</p> <p><b>Hülsenhals</b></p> <p>H1 * = 7.62</p> <p>H2 <sup>1)</sup> = 7.61</p> <p><b>Geschossübergang</b></p> <p>G1 <sup>1)</sup>* = 6.68</p> <p>G <sup>1)</sup>* = 14.00</p> <p>α1 = 180°</p> <p>h =</p> <p>s =</p> <p>i <sup>1)</sup> = 0°34'22"</p> <p>w =</p> <p><b>Lauf</b></p> <p>F <sup>1)</sup>* = 6.40</p> <p>Z <sup>1)</sup> = 6.64</p> <p><b>Züge</b></p> <p>b = 3.50</p> <p>N = 4</p> <p>u = 200.00</p> <p>Q = 33.94 mm<sup>2</sup></p>	
	<p>Maßstab 1:1</p> <p>Maße in &lt;&lt; mm &gt;&gt;</p> <p>Maße und Toleranzen für Messläufe siehe Anhang CR 1.</p>		<p>Bemerkungen: 1) Kontrolle aus Sicherheitsgründen * Grundmaße</p>	

<b>C.I.P.</b>	<b>6,5 x 54 Mannl. Sch.</b>	TAB. <b>I</b>
		Datum <b>84-06-14</b>
		Revision <b>02-05-15</b>
Ursprungsland: AT		
	<b>PATRONE MAXI</b>	<b>PATRONENLAGER MINI</b>
	<p><b>Längen</b></p> <p>L1 <sup>1)</sup>* = 41.82 -0.20                  L2 <sup>1)</sup>* = 45.60 -0.20                  L3 <sup>1)</sup> = 53.65                  L4 =                  L5 = 57.20                  L6 = 77.80</p> <p><b>Hülsenboden</b></p> <p>R = 1.05                  R1 = 11.52                  R3 =                  E = 3.40                  E1 = 9.70                  e min = 1.00                  delta = 33°15'                  f =                  beta = 45°</p> <p><b>Pulverkammer</b></p> <p>P1 = 11.47                  P2 <sup>1)</sup>* = 10.87 -0.20</p> <p><b>Schulterkonus</b></p> <p>alpha = 47°17'26"                  S = 54.24                  r1 min = 0.50                  r2 = 0.50</p> <p><b>Hülsenhals</b></p> <p>H1* = 7.56                  H2 <sup>1)</sup> = 7.49</p> <p><b>Geschoss</b></p> <p>G1 <sup>1)</sup> = 6.70                  G2 = 6.70                  F =                  L3+G <sup>1)</sup> = 74.80</p> <p><b>Drücke (Energien)</b></p> <p><b>Mech. elektr. Wandler</b></p> <p>Pmax = 3650 bar                  PK = 4198 bar                  PE = 4560 bar                  M = 25.00                  EE = 2430 Joule</p> <p><b>Verschiedene Daten</b></p> <p>Fe <sup>1)</sup> = 0.15                  delta L =</p>	<p><b>Längen</b></p> <p>L1* = 41.82                  L2* = 45.60                  L3 <sup>1)</sup> = 53.65</p> <p><b>Stoßboden</b></p> <p>R = 1.05                  R1 = 11.57                  R2 =                  R3 =                  r =</p> <p><b>Pulverkammer</b></p> <p>E = 3.30                  P1 <sup>1)</sup> = 11.52                  P2* = 10.92</p> <p><b>Schulterkonus</b></p> <p>alpha <sup>1)</sup> = 47°16'59"                  S = 54.29                  r1 max = 0.50                  r2 = 0.50</p> <p><b>Hülsenhals</b></p> <p>H1* = 7.61                  H2 <sup>1)</sup> = 7.54</p> <p><b>Geschossübergang</b></p> <p>G1 <sup>1)</sup>* = 6.90                  G <sup>1)</sup>* = 21.15                  alpha1 = 180°                  h =                  s =                  i <sup>1)</sup> = 0°34'08"                  w =</p> <p><b>Lauf</b></p> <p>F <sup>1)</sup>* = 6.48                  Z <sup>1)</sup> = 6.78</p> <p><b>Züge</b></p> <p>b = 3.50                  N = 4                  u = 200.00                  Q = 35.16 mm<sup>2</sup></p>
Maßstab 1:1		
Maße in << mm >> Maße und Toleranzen für Messläufe siehe Anhang CR 1.		Bemerkungen: 1) Kontrolle aus Sicherheitsgründen * Grundmaße

C.I.P.	6,5 x 55 SE	TAB.	I
		Datum	84-06-14
		Revision	13-05-22
		<b>PATRONE MAXI</b>	
		<b>PATRONE MIN</b>	
		<b>PATRONE MAXI</b>	
		<b>PATRONE MIN</b>	
<p>Maßstab 1.02:1</p> <p>Maße in &lt;&lt; mm &gt;&gt; Maße und Toleranzen für Messläufe siehe Anhang CR 1.</p>		<p>Bemerkungen: 1) Kontrolle aus Sicherheitsgründen 3) Verschlussabstand an Schulter * Grundmaße</p>	

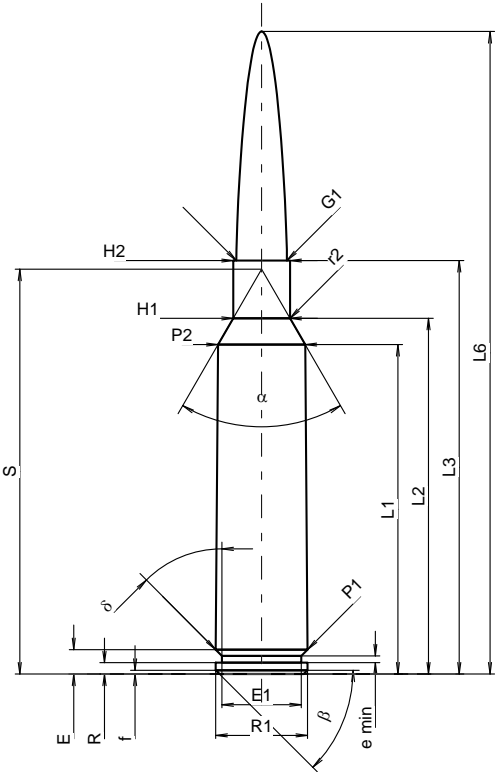
C.I.P.	6,5 x 55 T.R.I.	TAB.	I
		Datum	15-05-19
		Revision	
	<b>PATRONE MAXI</b> <b>Längen</b> L1 <sup>1)</sup> = 43.59 -0.20 L2 <sup>1)</sup> = 47.06 -0.20 L3 <sup>1)</sup> = 54.70 L4 = L5 = L6 = 85.00 <b>Hülsenboden</b> R = 1.50 R1 = 12.13 R3 = E = 3.23 E1 = 10.50 e min = 0.90 delta = 45° f = 0.50 beta = 45° <b>Pulverkammer</b> P1 = 12.15 P2 <sup>1)*</sup> = 11.52 -0.20 <b>Schulterkonus</b> alpha * = 60° S * = 53.56 r1 min = r2 = 1.52 <b>Hülsenhals</b> H1 * = 7.51 H2 <sup>1)</sup> = 7.51 <b>Geschoss</b> G1 <sup>1)</sup> = 6.70 G2 = F = L3+G <sup>1)</sup> = 64.15 <b>Drücke (Energien)</b> <b>Mech. elektr. Wandler</b> Pmax = 3800 bar PK = 4370 bar PE = 4750 bar M = 25.00 EE = 3400 Joule <b>Verschiedene Daten</b> Fe <sup>1)3)</sup> = 0.15 delta L =	<b>PATRONELAGER MINI</b> <b>Längen</b> L1 = 43.62 L2 = 47.12 L3 <sup>1)</sup> = 54.86 <b>Stoßboden</b> R = R1 = 12.18 R2 = R3 = r = <b>Pulverkammer</b> E = 3.23 P1 <sup>1)</sup> = 12.18 P2 * = 11.56 <b>Schulterkonus</b> alpha <sup>1)*</sup> = 60° S * = 53.63 r1 max = r2 = 1.52 <b>Hülsenhals</b> H1 * = 7.52 H2 <sup>1)</sup> = 7.52 <b>Geschossübergang</b> G1 <sup>1)*</sup> = 6.72 G <sup>1)</sup> = 9.45 alpha l = 90° h = 0.40 s * = 5.25 i <sup>1)*</sup> = 1°30' w = <b>Lauf</b> F <sup>1)*</sup> = 6.50 Z <sup>1)</sup> = 6.70 <b>Züge</b> b = 2.50 N = 4 u * = 203.20 Q = 34.21 mm <sup>2</sup>	
			<b>Ursprungsland: IT</b>
<p>Maßstab 1:1</p> <p>Maße in &lt;&lt; mm &gt;&gt;  Maße und Toleranzen für Messläufe  siehe Anhang CR1.</p>		<p>Bemerkungen: 1) Kontrolle aus Sicherheitsgründen  3) Verschlussabstand an Schulter  * Grundmaße</p>	

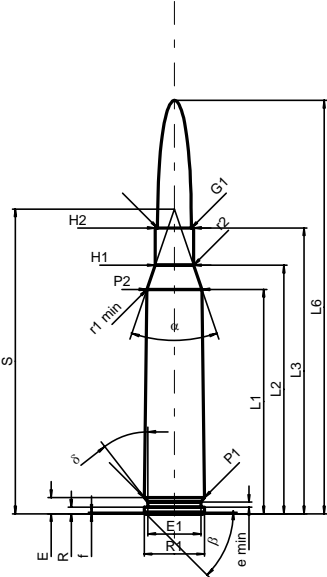
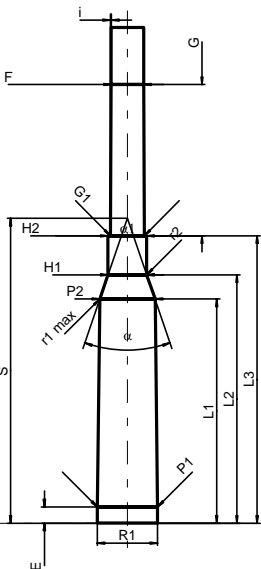
<b>C.I.P.</b>	<b>6,5 x 57</b>		<b>TAB. I</b>
	Ursprungsland: DE		<b>Datum 84-06-14</b>
			<b>Revision 02-05-15</b>
	<b>PATRONE MAXI</b>		<b>PATRONENLAGER MINI</b>
	<p><b>Längen</b></p> <p>L1 <sup>1)</sup>* = 44.50 -0.20                  L2 <sup>1)</sup>* = 49.30 -0.20                  L3 <sup>1)</sup> = 56.70                  L4 =                  L5 = 59.00                  L6 = 82.00</p> <p><b>Hülsenboden</b></p> <p>R = 1.30                  R1 = 11.95                  R3 =                  E = 3.20                  E1 = 10.50                  e min = 1.00                  δ = 37°52'48"                  f = 0.30                  β = 45°</p> <p><b>Pulverkammer</b></p> <p>P1 = 11.90                  P2 <sup>1)</sup>* = 10.94 -0.20</p> <p><b>Schulterkonus</b></p> <p>α = 37°50'02"                  S = 60.46                  r1 min = 0.50                  r2 = 0.50</p> <p><b>Hülsenhals</b></p> <p>H1 * = 7.65                  H2 <sup>1)</sup> = 7.65</p> <p><b>Geschoss</b></p> <p>G1 <sup>1)</sup> = 6.70                  G2 = 6.70                  F =                  L3+G <sup>1)</sup> = 86.70</p> <p><b>Drücke (Energien)</b>  <b>Mech. elektr. Wandler</b></p> <p>Pmax = 3900 bar                  PK = 4485 bar                  PE = 4875 bar                  M = 25.00                  EE = 3260 Joule</p> <p><b>Verschiedene Daten</b></p> <p>Fe <sup>1)</sup> = 0.10                  delta L =</p>		<p><b>Längen</b></p> <p>L1 * = 44.46                  L2 * = 49.26                  L3 <sup>1)</sup> = 57.00</p> <p><b>Stoßboden</b></p> <p>R = 1.30                  R1 = 12.00                  R2 =                  R3 =                  r =</p> <p><b>Pulverkammer</b></p> <p>E = 3.20                  P1 <sup>1)</sup> = 11.93                  P2 * = 10.97</p> <p><b>Schulterkonus</b></p> <p>α <sup>1)</sup> = 37°49'59"                  S = 60.46                  r1 max = 0.50                  r2 = 0.50</p> <p><b>Hülsenhals</b></p> <p>H1 * = 7.68                  H2 <sup>1)</sup> = 7.67</p> <p><b>Geschossübergang</b></p> <p>G1 <sup>1)</sup>* = 6.75                  G <sup>1)</sup>* = 30.00                  α1 = 180°                  h =                  s =                  i <sup>1)</sup> = 0°17'11"                  w =</p> <p><b>Lauf</b></p> <p>F <sup>1)</sup>* = 6.45                  Z <sup>1)</sup> = 6.70</p> <p><b>Züge</b></p> <p>b = 3.50                  N = 4                  u = 200.00                  Q = 34.52 mm<sup>2</sup></p>
			
Maßstab 1:1.5			
Maße in << mm >> Maße und Toleranzen für Messläufe siehe Anhang CR 1.		Bemerkungen: 1) Kontrolle aus Sicherheitsgründen * Grundmaße	

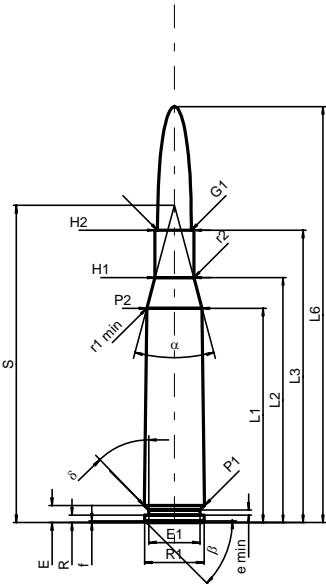
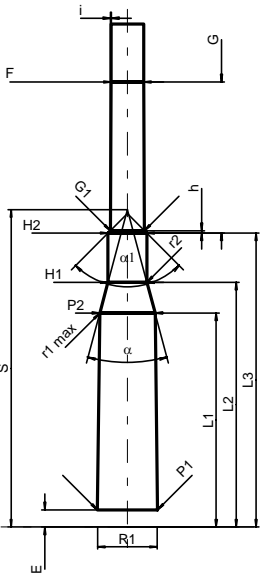
<b>C.I.P.</b>	<b>6,5 x 58 Mauser</b>  Ursprungsland: DE	<b>TAB.</b>	<b>I</b>
		Datum	84-06-14
		Revision	02-05-15
	<b>PATRONE MAXI</b>	<b>PATRONENLAGER MINI</b>	
	<p><b>Längen</b></p> <p>L1 <sup>1)</sup>* = 42.52 -0.20                      L2 <sup>1)</sup>* = 48.58 -0.20                      L3 <sup>1)</sup> = 58.00                      L4 =                      L5 =                      L6 = 82.50</p> <p><b>Hülsenboden</b></p> <p>R = 1.50                      R1 = 11.80                      R3 =                      E = 3.40                      E1 = 10.20                      e min = 1.00                      delta = 45°                      f = 0.30                      beta = 45°</p> <p><b>Pulverkammer</b></p> <p>P1 = 11.95                      P2 <sup>1)</sup>* = 10.95 -0.20</p> <p><b>Schulterkonus</b></p> <p>alpha = 30°01'18"                      S = 62.94                      r1 min = 0.50                      r2 = 0.50</p> <p><b>Hülsenhals</b></p> <p>H1 * = 7.70                      H2 <sup>1)</sup> = 7.70</p> <p><b>Geschoss</b></p> <p>G1 <sup>1)</sup> = 6.70                      G2 =                      F =                      L3+G <sup>1)</sup> = 88.00</p> <p><b>Drücke (Energien)</b></p> <p><b>Mech. elektr. Wandler</b></p> <p>Pmax = 3550 bar                      PK = 4083 bar                      PE = 4440 bar                      M = 25.00                      EE = 3330 Joule</p> <p><b>Verschiedene Daten</b></p> <p>Fe <sup>1)</sup> = 0.15                      delta L =</p>	<p><b>Längen</b></p> <p>L1 * = 42.46                      L2 * = 48.53                      L3 <sup>1)</sup> = 58.30</p> <p><b>Stoßboden</b></p> <p>R = 1.50                      R1 = 11.85                      R2 =                      R3 =                      r =</p> <p><b>Pulverkammer</b></p> <p>E = 3.40                      P1 <sup>1)</sup> = 11.98                      P2 * = 10.98</p> <p><b>Schulterkonus</b></p> <p>alpha <sup>1)</sup> = 29°58'28"                      S = 62.97                      r1 max = 0.50                      r2 = 0.50</p> <p><b>Hülsenhals</b></p> <p>H1 * = 7.73                      H2 <sup>1)</sup> = 7.72</p> <p><b>Geschossübergang</b></p> <p>G1 <sup>1)</sup>* = 6.75                      G <sup>1)</sup>* = 30.00                      alpha1 = 90°                      h * = 0.49                      s <sup>1)</sup> =                      i = 0°17'28"                      w =</p> <p><b>Lauf</b></p> <p>F <sup>1)</sup>* = 6.45                      Z <sup>1)</sup> = 6.70</p> <p><b>Züge</b></p> <p>b = 3.50                      N = 4                      u = 200.00                      Q = 34.52 mm<sup>2</sup></p>	
	<p>Maßstab 1:1.5</p> <p>Maße in &lt;&lt; mm &gt;&gt; Maße und Toleranzen für Messläufe siehe Anhang CR 1.</p>		
<p>Bemerkungen: 1) Kontrolle aus Sicherheitsgründen * Grundmaße</p>			



<b>C.I.P.</b>	<b>6,5 x 63 Messner Mag.</b>	TAB.	I
		Datum	02-01-22
		Revision	02-05-15
Ursprungsland: FR			
	<b>PATRONE MAXI</b>	<b>PATRONENLAGER MINI</b>	
	<p><b>Längen</b></p> <p>L1 <sup>1)</sup>* = 51.55 -0.20</p> <p>L2 <sup>1)</sup>* = 55.96 -0.20</p> <p>L3 <sup>1)</sup> = 63.00</p> <p>L4 =</p> <p>L5 =</p> <p>L6 = 84.50</p> <p><b>Hülsenboden</b></p> <p>R = 1.30</p> <p>R1 = 12.63</p> <p>R3 =</p> <p>E = 3.20</p> <p>E1 = 11.20</p> <p>e min = 1.00</p> <p>δ = 43°</p> <p>f = 0.30</p> <p>β = 45°</p> <p><b>Pulverkammer</b></p> <p>P1 = 12.85</p> <p>P2 <sup>1)</sup>* = 12.40 -0.20</p> <p><b>Schulterkonus</b></p> <p>α = 57°54'38"</p> <p>S = 62.76</p> <p>r1 min = 0.67</p> <p>r2 = 2.00</p> <p><b>Hülsenhals</b></p> <p>H1 <sup>*</sup> = 7.52</p> <p>H2 <sup>1)</sup> = 7.52</p> <p><b>Geschoss</b></p> <p>G1 <sup>1)</sup> = 6.71</p> <p>G2 =</p> <p>F =</p> <p>L3+G <sup>1)</sup> = 89.41</p> <p><b>Drücke (Energien)</b></p> <p><b>Mech. elektr. Wandler</b></p> <p>Pmax = 4400 bar</p> <p>PK = 5060 bar</p> <p>PE = 5500 bar</p> <p>M = 25.00</p> <p>EE = 4200 Joule</p> <p><b>Verschiedene Daten</b></p> <p>Fe <sup>1)</sup> = 0.10</p> <p>delta L =</p>	<p><b>Längen</b></p> <p>L1 <sup>*</sup> = 51.53</p> <p>L2 <sup>*</sup> = 55.93</p> <p>L3 <sup>1)</sup> = 63.25</p> <p><b>Stoßboden</b></p> <p>R = 1.30</p> <p>R1 = 12.65</p> <p>R2 =</p> <p>R3 =</p> <p>r =</p> <p><b>Pulverkammer</b></p> <p>E = 3.20</p> <p>P1 <sup>1)</sup> = 12.88</p> <p>P2 <sup>*</sup> = 12.43</p> <p><b>Schulterkonus</b></p> <p>α <sup>1)</sup> = 58°01'15"</p> <p>S = 62.74</p> <p>r1 max = 0.34</p> <p>r2 = 2.00</p> <p><b>Hülsenhals</b></p> <p>H1 <sup>*</sup> = 7.55</p> <p>H2 <sup>1)</sup> = 7.55</p> <p><b>Geschossübergang</b></p> <p>G1 <sup>1)</sup>* = 6.71</p> <p>G <sup>1)</sup>* = 26.41</p> <p>α1 = 90°</p> <p>h <sup>*</sup> = 0.42</p> <p>s =</p> <p>i <sup>1)</sup> = 0°17'12"</p> <p>w =</p> <p><b>Lauf</b></p> <p>F <sup>1)</sup>* = 6.45</p> <p>Z <sup>1)</sup> = 6.70</p> <p><b>Züge</b></p> <p>b = 3.50</p> <p>N = 4</p> <p>u = 200.00</p> <p>Q = 34.52 mm<sup>2</sup></p>	
<p>Maßstab 1:1.19</p> <p style="text-align: center;">Maße in &lt;&lt; mm &gt;&gt;</p> <p style="text-align: center;">Maße und Toleranzen für Messläufe siehe Anhang CR 1.</p>		<p>Bemerkungen: 1) Kontrolle aus Sicherheitsgründen * Grundmaße</p>	

<b>C.I.P.</b>	<b>6,5 x 64</b>		<b>TAB.</b>	<b>I</b>
	Ursprungsland: DE		Datum	92-02-27
			Revision	02-05-15
	<b>PATRONE MAXI</b>		<b>PATRONENLAGER MINI</b>	
	<p><b>Längen</b></p> <p>L1 <sup>1)</sup>* = 51.97 -0.20</p> <p>L2 <sup>1)</sup>* = 54.32 -0.20</p> <p>L3 <sup>1)</sup> = 64.00</p> <p>L4 =</p> <p>L5 =</p> <p>L6 = 84.00</p> <p><b>Hülsenboden</b></p> <p>R = 1.30</p> <p>R1 = 11.95</p> <p>R3 =</p> <p>E = 3.20</p> <p>E1 = 10.50</p> <p>e min = 1.00</p> <p>δ = 36°15'</p> <p>f = 0.30</p> <p>β = 45°</p> <p><b>Pulverkammer</b></p> <p>P1 = 11.82</p> <p>P2 <sup>1)</sup>* = 11.60 -0.20</p> <p><b>Schulterkonus</b></p> <p>α = 80°05'21"</p> <p>S = 58.87</p> <p>r1 min =</p> <p>r2 =</p> <p><b>Hülsenhals</b></p> <p>H1* = 7.65</p> <p>H2 <sup>1)</sup> = 7.64</p> <p><b>Geschoss</b></p> <p>G1 <sup>1)</sup> = 6.70</p> <p>G2 =</p> <p>F =</p> <p>L3+G <sup>1)</sup> = 72.00</p> <p><b>Drücke (Energien)</b></p> <p><b>Mech. elektr. Wandler</b></p> <p>Pmax = 4300 bar</p> <p>PK = 4945 bar</p> <p>PE = 5375 bar</p> <p>M = 25.00</p> <p>EE = 3645 Joule</p> <p><b>Verschiedene Daten</b></p> <p>Fe <sup>1)</sup> = 0.10</p> <p>delta L =</p>		<p><b>Längen</b></p> <p>L1* = 51.95</p> <p>L2* = 54.30</p> <p>L3 <sup>1)</sup> = 64.30</p> <p><b>Stoßboden</b></p> <p>R = 1.30</p> <p>R1 = 12.00</p> <p>R2 =</p> <p>R3 =</p> <p>r =</p> <p><b>Pulverkammer</b></p> <p>E = 3.20</p> <p>P1 <sup>1)</sup> = 11.84</p> <p>P2* = 11.63</p> <p><b>Schulterkonus</b></p> <p>α <sup>1)</sup> = 80°05'21"</p> <p>S = 58.87</p> <p>r1 max =</p> <p>r2 =</p> <p><b>Hülsenhals</b></p> <p>H1* = 7.68</p> <p>H2 <sup>1)</sup> = 7.67</p> <p><b>Geschossübergang</b></p> <p>G1 <sup>1)</sup>* = 6.72</p> <p>G <sup>1)</sup>* = 8.00</p> <p>α1 = 180°</p> <p>h =</p> <p>s =</p> <p>i <sup>1)</sup> = 0°58'</p> <p>w =</p> <p><b>Lauf</b></p> <p>F <sup>1)</sup>* = 6.45</p> <p>Z <sup>1)</sup> = 6.70</p> <p><b>Züge</b></p> <p>b = 3.60</p> <p>N = 4</p> <p>u = 228.00</p> <p>Q = 34.58 mm<sup>2</sup></p>	
Maßstab 1:1				
<p>Maße in &lt;&lt; mm &gt;&gt;</p> <p>Maße und Toleranzen für Messläufe siehe Anhang CR 1.</p>		<p>Bemerkungen: 1) Kontrolle aus Sicherheitsgründen * Grundmaße</p>		

<b>C.I.P.</b>	<b>6,5 x 64 Brenneke</b>	<b>TAB. I</b>	
		<b>Datum</b>	<b>92-02-27</b>
		<b>Revision</b>	<b>13-05-22</b>
Ursprungsland: DE			
	<b>PATRONE MAXI</b>		
	<p><b>Längen</b></p> <p>L1 <sup>1)</sup>* = 49.50 -0.20                  L2 <sup>1)</sup>* = 55.40 -0.20                  L3 <sup>1)</sup> = 64.52                  L4 =                  L5 =                  L6 = 84.84</p> <p><b>Hülsenboden</b></p> <p>R = 1.24                  R1 = 12.01                  R3 =                  E = 3.23                  E1 = 10.39                  e min = 0.90                  delta = 36°                  f = 0.91                  beta = 72°</p> <p><b>Pulverkammer</b></p> <p>P1 = 11.97                  P2 <sup>1)</sup>* = 11.21 -0.20</p> <p><b>Schulterkonus</b></p> <p>alpha = 35°20'54"                  S = 67.09                  r1 min = 1.02                  r2 = 3.18</p> <p><b>Hülsenhals</b></p> <p>H1 * = 7.45                  H2 <sup>1)</sup> = 7.42</p> <p><b>Geschoss</b></p> <p>G1 <sup>1)</sup> = 6.70                  G2 =                  F =                  L3+G <sup>1)</sup> = 71.10</p> <p><b>Drücke (Energien)</b></p> <p><b>Mech. elektr. Wandler</b></p> <p>Pmax = 4300 bar                  PK = 4945 bar                  PE = 5190 bar                  M = 25.00                  EE = 3645 Joule</p> <p><b>Verschiedene Daten</b></p> <p>Fe <sup>1)3)</sup> = 0.10                  delta L = 0.18</p>		<b>PATRONENLAGER MINI</b>
		<p><b>Längen</b></p> <p>L1 * = 49.28                  L2 * = 55.32                  L3 <sup>1)</sup> = 65.02</p> <p><b>Stoßboden</b></p> <p>R =                  R1 = 12.04                  R2 =                  R3 =                  r =</p> <p><b>Pulverkammer</b></p> <p>E = 3.17                  P1 <sup>1)</sup> = 11.98                  P2 * = 11.23</p> <p><b>Schulterkonus</b></p> <p>alpha <sup>1)</sup> = 34°29'30"                  S = 67.37                  r1 max = 0.76                  r2 = 3.18</p> <p><b>Hülsenhals</b></p> <p>H1 * = 7.48                  H2 <sup>1)</sup> = 7.45</p> <p><b>Geschossübergang</b></p> <p>G1 <sup>1)</sup>* = 6.70                  G <sup>1)</sup>* = 6.58                  alpha1 = 75°                  h = 0.49                  s * = 3.00                  i <sup>1)</sup> = 1°59'35"                  w =</p> <p><b>Lauf</b></p> <p>F <sup>1)</sup>* = 6.45                  Z <sup>1)</sup> = 6.70</p> <p><b>Züge</b></p> <p>b = 3.50                  N = 4                  u = 255.00                  Q = 34.52 mm<sup>2</sup></p>	
Maßstab 1:1.09  Maße in << mm >> Maße und Toleranzen für Messläufe siehe Anhang CR 1.		Bemerkungen: 1) Kontrolle aus Sicherheitsgründen 3) Verschlussabstand an Schulter * Grundmaße	

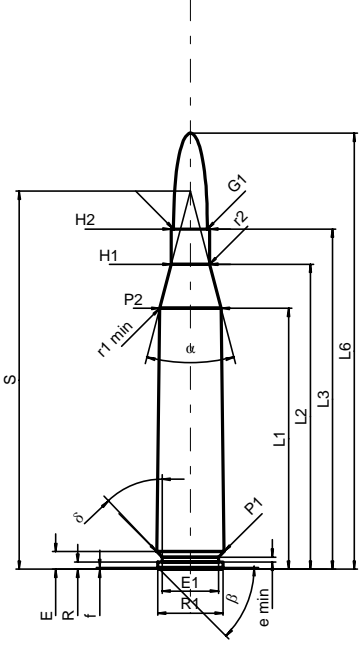
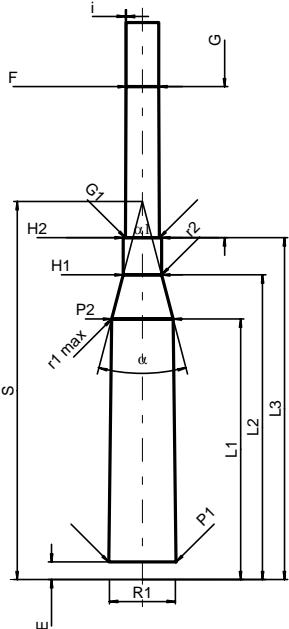

<b>C.I.P.</b>	<b>6,5 x 68</b> Ursprungsland: DE	TAB. <b>I</b>
		Datum <b>84-06-14</b>
		Revision <b>02-05-15</b>
	<b>PATRONE MAXI</b>	<b>PATRONENLAGER MINI</b>
	<p><b>Längen</b></p> <p>L1 <sup>1)</sup>* = 51.75 -0.20                  L2 <sup>1)</sup>* = 60.50 -0.20                  L3 <sup>1)</sup> = 67.50                  L4 =                  L5 = 67.90                  L6 = 86.50</p> <p><b>Hülsenboden</b></p> <p>R = 1.40                  R1 = 13.00                  R3 =                  E = 3.50                  E1 = 11.20                  e min = 1.00                  delta = 43°40'12"                  f = 0.30                  beta = 45°</p> <p><b>Pulverkammer</b></p> <p>P1 = 13.30                  P2 <sup>1)</sup>* = 12.18 -0.20</p> <p><b>Schulterkonus</b></p> <p>alpha = 29°19'56"                  S = 75.02                  r1 min = 0.50                  r2 = 0.50</p> <p><b>Hülsenhals</b></p> <p>H1 * = 7.60                  H2 = 7.60</p> <p><b>Geschoss</b></p> <p>G1 <sup>1)</sup> = 6.70                  G2 <sup>1)</sup> = 6.70                  F =                  L3+G <sup>1)</sup> = 97.50</p> <p><b>Drücke (Energien)</b></p> <p><b>Mech. elektr. Wandler</b></p> <p>Pmax = 4400 bar                  PK = 5060 bar                  PE = 5500 bar                  M = 25.00                  EE = 4045 Joule</p> <p><b>Verschiedene Daten</b></p> <p>Fe <sup>1)</sup> = 0.10                  delta L =</p>	<p><b>Längen</b></p> <p>L1 * = 51.70                  L2 * = 60.45                  L3 <sup>1)</sup> = 67.80</p> <p><b>Stoßboden</b></p> <p>R = 1.40                  R1 = 13.05                  R2 =                  R3 =                  r =</p> <p><b>Pulverkammer</b></p> <p>E = 3.50                  P1 <sup>1)</sup> = 13.33                  P2 * = 12.21</p> <p><b>Schulterkonus</b></p> <p>alpha = 29°19'56"                  S = 75.03                  r1 max = 0.50                  r2 = 0.50</p> <p><b>Hülsenhals</b></p> <p>H1 * = 7.63                  H2 <sup>1)</sup> = 7.62</p> <p><b>Geschossübergang</b></p> <p>G1 <sup>1)</sup>* = 6.75                  G <sup>1)</sup>* = 30.00                  alpha1 = 180°                  h =                  s =                  i <sup>1)</sup> = 0°17'11"                  w =</p> <p><b>Lauf</b></p> <p>F <sup>1)</sup>* = 6.45                  Z <sup>1)</sup> = 6.70</p> <p><b>Züge</b></p> <p>b = 3.50                  N = 4                  u = 250.00                  Q = 34.52 mm<sup>2</sup></p>
		
<p>Maßstab 1:1.5</p> <p>Maße in &lt;&lt; mm &gt;&gt;                  Maße und Toleranzen für Messläufe                  siehe Anhang CR 1.</p>		<p>Bemerkungen: 1) Kontrolle aus Sicherheitsgründen                  * Grundmaße</p>

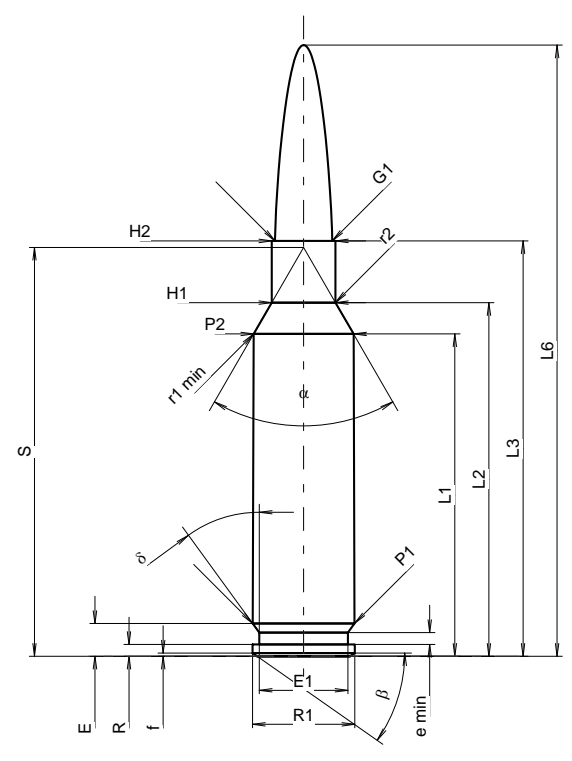
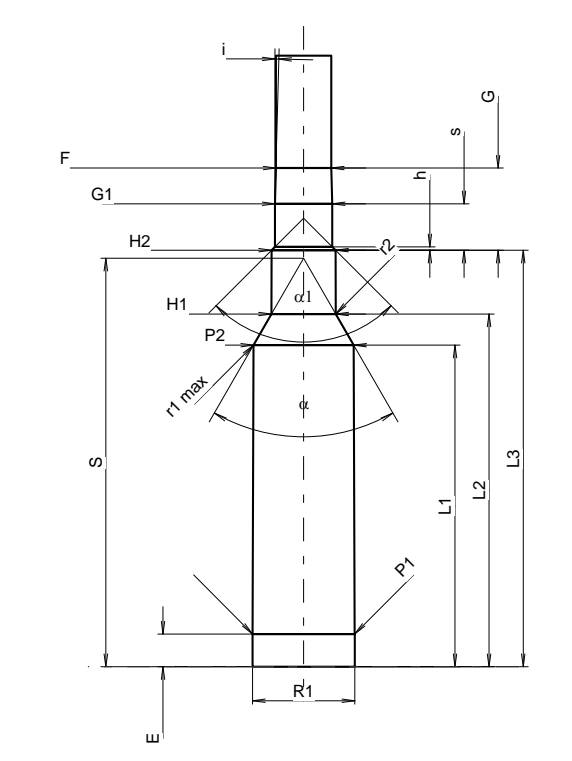
<b>C.I.P.</b>	<b>6,5 Creedmoor</b>		<b>TAB.</b>	<b>I</b>
	Ursprungsland: US		Datum	12-05-30
			Revision	
	<b>PATRONE MAXI</b>		<b>PATRONENLAGER MINI</b>	
	<p><b>Längen</b></p> <p>L1 <sup>1)</sup> = 37.84 -0.20                  L2 <sup>1)</sup> = 41.52 -0.20                  L3 <sup>1)</sup> = 48.77                  L4 =                  L5 =                  L6 = 71.76</p> <p><b>Hülsenboden</b></p> <p>R = 1.37                  R1 = 12.01                  R3 =                  E = 3.84                  E1 = 10.39                  e min = 1.40                  delta = 36°                  f = 0.38                  beta = 35°</p> <p><b>Pulverkammer</b></p> <p>P1 = 11.95                  P2 <sup>1)</sup>* = 11.74 -0.20</p> <p><b>Schulterkonus</b></p> <p>alpha * = 60°                  S * = 48.01                  r1 min = 0.76                  r2 = 3.18</p> <p><b>Hülsenhals</b></p> <p>H1 * = 7.49                  H2 <sup>1)</sup> = 7.49</p> <p><b>Geschoss</b></p> <p>G1 <sup>1)</sup> = 6.72                  G2 =                  F =                  L3+G <sup>1)</sup> = 58.42</p> <p><b>Drücke (Energien)</b></p> <p><b>Mech. elektr. Wandler</b></p> <p>Pmax = 4350 bar                  PK = 5003 bar                  PE = 5438 bar                  M = 25.00                  EE = 3400 Joule</p> <p><b>Verschiedene Daten</b></p> <p>Fe <sup>1)3)</sup> = 0.10                  delta L = 0.06</p>		<p><b>Längen</b></p> <p>L1 = 37.76                  L2 = 41.42                  L3 <sup>1)</sup> = 48.90</p> <p><b>Stoßboden</b></p> <p>R =                  R1 = 12.01                  R2 =                  R3 =                  r =</p> <p><b>Pulverkammer</b></p> <p>E = 3.84                  P1 <sup>1)</sup> = 11.98                  P2 * = 11.76</p> <p><b>Schulterkonus</b></p> <p>alpha <sup>1)</sup>* = 60°                  S * = 47.95                  r1 max = 0.76                  r2 = 3.18</p> <p><b>Hülsenhals</b></p> <p>H1 * = 7.54                  H2 <sup>1)</sup> = 7.52</p> <p><b>Geschossübergang</b></p> <p>G1 <sup>1)</sup>* = 6.72                  G <sup>1)</sup> = 9.65                  F =                  alpha l = 90°                  h = 0.40                  s * = 5.45                  i <sup>1)</sup>* = 1°30'                  w =</p> <p><b>Lauf</b></p> <p>F <sup>1)</sup>* = 6.50                  Z <sup>1)</sup> = 6.71</p> <p><b>Züge</b></p> <p>b = 2.29                  N = 6                  u = 203.00                  Q = 34.66 mm<sup>2</sup></p>	
				
Maßstab 1.13:1  Maße in << mm >> Maße und Toleranzen für Messläufe siehe Anhang CR1.		Bemerkungen: 1) Kontrolle aus Sicherheitsgründen 3) Verschlussabstand an Schulter * Grundmaße		

1. Patronen ohne Rand

# C.I.P.

# 6,5 Grendel

Country of Origin: **US**

TAB: 39 von 185

Date: 13-05-22

Revision: 15-05-19

Alternative Names: -

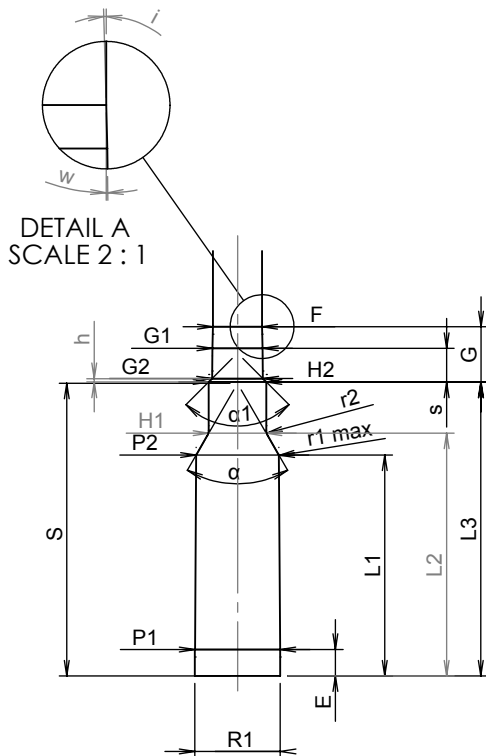
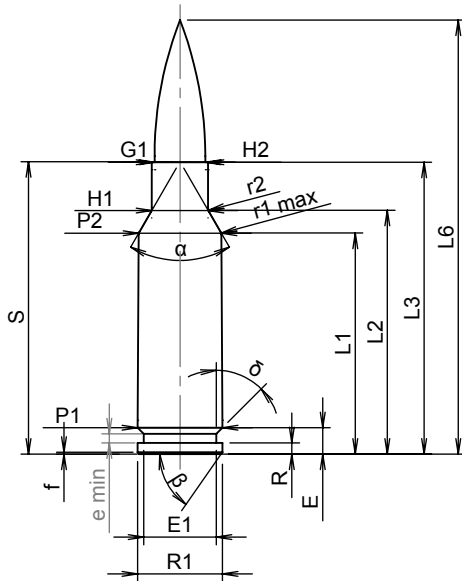

**CARTRIDGE MAXI**

**Lengths**

- L1<sup>1)</sup> = **29.23**    **-0.20**
- L2<sup>1)</sup> = **32.25**    **-0.20**
- L3<sup>1)</sup> = **38.61**
- L4 = -
- L5 = -
- L6 = **57.40**

**Case Head**

- R = **1.50**
- R1 = **11.20**
- R3 = -
- E = **3.5**
- E1 = **9.60**
- e min = **1.19**
- O = **45.00°**
- f = **0.25**
- β = **55.00°**

**Powder Chamber**

- P1 = **11.22**
- P2<sup>1)\*</sup> = **10.92**    **-0.20**

**Junction Cone**

- α\* = **60.00°**
- S\* = **38.68**
- r1 min = **0.76**
- r2 = **1.27**

**Collar**

- H1\* = **7.44**
- H2<sup>1)</sup> = **7.44**

**Projectile**

- G1<sup>1)</sup> = **6.71**
- G2 = -
- F = -
- L3+G<sup>1)</sup> = **45.93**

**Pressures(Energies)  
Method Transducer**

- Pmax = **4050 bar**
- PK = **4658 bar**
- PE = **5063 bar**
- M = **25.00**
- EE = **2800 Joule**

**Miscellaneous Dimensions**

- Fe<sup>1)3)</sup> = **0.10**
- delta L = -

**CHAMBER MINI**

**Lengths**

- L1 = **29.21**
- L2 = **32.09**
- L3<sup>1)</sup> = **38.86**

**Breech**

- R = -
- R1 = **11.30**
- R2 = -
- R3 = -
- r = -

**Powder Chamber**

- E = **3.5**
- P1<sup>1)</sup> = **11.26**
- P2\* = **10.95**

**Junction Cone**

- α<sup>1)\*</sup> = **60.00°**
- S\* = **38.69**
- r1 max = **0.51**
- r2 = **1.52**

**Collar**

- H1\* = **7.62**
- H2<sup>1)</sup> = **7.62**
- G2<sup>1)\*</sup> = **6.72**

**Commencement of Rifling**

- G1<sup>1)\*</sup> = **6.65**
- G<sup>1)</sup> = **7.32**
- α1 = **90.00°**
- h = **0.45**
- s\* = **4.46**
- j<sup>1)\*</sup> = **1°30'00"**
- w<sup>1)\*</sup> = **0°30'00"**

**Barrel**

- F<sup>1)\*</sup> = **6.50**
- Z<sup>1)</sup> = **6.71**

**Grooves**

- b = **2.29**
- N = **6**
- u = **200**
- Q = **34.66 mm<sup>2</sup>**

Dimensions in <<mm>>  
Dimensions and Tolerances for Proof Barrels  
see Appendix CR1.

Notes: 1) Check for safety reason  
3) Headspace on Shoulder  
\* Basic dimensions

<b>C.I.P.</b>	<b>6,5 mm D.B.G.</b>	TAB. <span style="float: right;">I</span>
		Datum <span style="float: right;">15-05-19</span>
		Revision
Ursprungsland: IT		
	<b>PATRONE MAXI</b>	<b>PATRONENLAGER MINI</b>
	<p><b>Längen</b></p> <p>L1 <sup>1)</sup> = 38.92 -0.20                  L2 <sup>1)</sup> = 44.19 -0.20                  L3 <sup>1)</sup> = 51.90                  L4 =                  L5 =                  L6 = 72.00</p> <p><b>Hülsenboden</b></p> <p>R = 1.27                  R1 = 13.56                  R3 =                  E = 3.75                  E1 = 12.07                  e min = 0.94                  delta = 32°                  f = 0.41                  beta = 35°</p> <p><b>Pulverkammer</b></p> <p>P1 = 14.00                  P2 <sup>1)</sup>* = 13.59 -0.20</p> <p><b>Schulterkonus</b></p> <p>alpha * = 60°02'18"                  S * = 50.68                  r1 min =                  r2 =</p> <p><b>Hülsenhals</b></p> <p>H1 * = 7.50                  H2 <sup>1)</sup> = 7.50</p> <p><b>Geschoss</b></p> <p>G1 <sup>1)</sup> = 6.71                  G2 =                  F =                  L3+G <sup>1)</sup> = 58.62</p> <p><b>Drücke (Energien)</b></p> <p><b>Mech. elektr. Wandler</b></p> <p>Pmax = 4400 bar                  PK = 5060 bar                  PE = 5500 bar                  M = 25.00                  EE = 3800 Joule</p> <p><b>Verschiedene Daten</b></p> <p>Fe <sup>1)3)</sup> = 0.10                  delta L =</p>	<p><b>Längen</b></p> <p>L1 = 38.95                  L2 = 44.22                  L3 <sup>1)</sup> = 51.93</p> <p><b>Stoßboden</b></p> <p>R =                  R1 = 14.05                  R2 =                  R3 =                  r =</p> <p><b>Pulverkammer</b></p> <p>E = 3.75                  P1 <sup>1)</sup> = 14.02                  P2 * = 13.60</p> <p><b>Schulterkonus</b></p> <p>alpha <sup>1)</sup>* = 59°57'25"                  S * = 50.74                  r1 max =                  r2 =</p> <p><b>Hülsenhals</b></p> <p>H1 * = 7.52                  H2 <sup>1)</sup> = 7.52</p> <p><b>Geschossübergang</b></p> <p>G1 <sup>1)</sup>* = 6.72                  G <sup>1)</sup> = 6.72                  alpha1 = 90°                  h = 0.40                  s * = 2.44                  i <sup>1)</sup>* = 1°28'20"                  w =</p> <p><b>Lauf</b></p> <p>F <sup>1)</sup>* = 6.50                  Z <sup>1)</sup> = 6.71</p> <p><b>Züge</b></p> <p>b = 1.73                  N = 6                  u * = 254.00                  Q = 34.29 mm<sup>2</sup></p>
<p>Maßstab 1:1</p> <p style="text-align: center;">Maße in &lt;&lt; mm &gt;&gt; Maße und Toleranzen für Messläufe siehe Anhang .</p>		<p>Bemerkungen: 1) Kontrolle aus Sicherheitsgründen                  3) Verschlussabstand an Schulter                  * Grundmaße</p>



<b>C.I.P.</b>	<b>6,5 mm Lahoz</b>		<b>TAB.</b>	<b>I</b>
	Ursprungsland: FR		Datum	11-05-25
			Revision	
	<b>PATRONE MAXI</b>		<b>PATRONENLAGER MINI</b>	
	<p><b>Längen</b></p> <p>L1 <sup>1)</sup> = 33.52 -0.20                      L2 <sup>1)</sup> = 37.30 -0.20                      L3 <sup>1)</sup> = 42.87                      L4 =                      L5 =                      L6 = 57.40</p> <p><b>Hülsenboden</b></p> <p>R = 1.50                      R1 = 11.45                      R3 =                      E = 3.20                      E1 = 9.95                      e min = 1.50                      delta = 74°40'48"                      f = 0.30                      beta = 45°</p> <p><b>Pulverkammer</b></p> <p>P1 = 11.41                      P2 <sup>1)</sup>* = 10.94 -0.20</p> <p><b>Schulterkonus</b></p> <p>alpha * = 48°18'15"                      S * = 45.72                      r1 min = 3.00                      r2 = 2.00</p> <p><b>Hülsenhals</b></p> <p>H1 * = 7.55                      H2 <sup>1)</sup> = 7.55</p> <p><b>Geschoss</b></p> <p>G1 <sup>1)</sup>* = 6.71                      G2 =                      F =                      L3+G <sup>1)</sup> = 48.49</p> <p><b>Drücke (Energien)</b></p> <p><b>Mech. elektr. Wandler</b></p> <p>Pmax = 3450 bar                      PK = 3968 bar                      PE = 4313 bar                      M = 25.00                      EE = 2010 Joule</p> <p><b>Verschiedene Daten</b></p> <p>Fe <sup>1)3)</sup> = 0.15                      delta L = 0.14</p>		<p><b>Längen</b></p> <p>L1 = 33.42                      L2 = 37.20                      L3 <sup>1)</sup> = 42.72</p> <p><b>Stoßboden</b></p> <p>R =                      R1 = 11.47                      R2 =                      R3 =                      r =</p> <p><b>Pulverkammer</b></p> <p>E = 3.20                      P1 <sup>1)</sup> = 11.46                      P2 * = 10.95</p> <p><b>Schulterkonus</b></p> <p>alpha <sup>1)</sup>* = 48°10'40"                      S * = 45.67                      r1 max = 3.00                      r2 = 2.00</p> <p><b>Hülsenhals</b></p> <p>H1 * = 7.57                      H2 <sup>1)</sup> = 7.57</p> <p><b>Geschossübergang</b></p> <p>G1 <sup>1)</sup>* = 6.73                      G <sup>1)</sup> = 5.62                      alpha l = 90°                      h = 0.42                      s = 3.43                      i <sup>1)</sup>* = 3°                      w =</p> <p><b>Lauf</b></p> <p>F <sup>1)</sup>* = 6.50                      Z <sup>1)</sup> = 6.70</p> <p><b>Züge</b></p> <p>b = 2.42                      N = 6                      u = 228.60                      Q = 34.67 mm<sup>2</sup></p>	
<p>Maßstab 1:18:1</p> <p>Maße in &lt;&lt; mm &gt;&gt;                      Maße und Toleranzen für Messläufe                      siehe Anhang CR 1.</p>		<p>Bemerkungen: 1) Kontrolle aus Sicherheitsgründen                      3) Verschlussabstand an Schulter                      * Grundmaße</p>		



<b>C.I.P.</b>	<b>7 x 33 Sako</b>		<b>TAB.</b>	<b>I</b>
	Ursprungsland: FI		<b>Datum</b>	<b>95-03-09</b>
			<b>Revision</b>	<b>02-05-15</b>
	<b>PATRONE MAXI</b>		<b>PATRONENLAGER MINI</b>	
	<p><b>Längen</b></p> <p>L1 <sup>1)</sup>* = 26.68 -0.20                  L2 <sup>1)</sup>* = 29.10 -0.20                  L3 <sup>1)</sup> = 33.33                  L4 =                  L5 =                  L6 = 44.44</p> <p><b>Hülsenboden</b></p> <p>R = 1.27                  R1 = 10.00                  R3 =                  E = 3.05                  E1 = 8.80                  e min = 0.90                  delta = 32°42'                  f = 0.30                  beta = 45°</p> <p><b>Pulverkammer</b></p> <p>P1 = 9.93                  P2 <sup>1)</sup>* = 9.52 -0.20</p> <p><b>Schulterkonus</b></p> <p>alpha = 35°56'39"                  S = 41.35                  r1 min =                  r2 =</p> <p><b>Hülsenhals</b></p> <p>H1 <sup>1)</sup>* = 7.95                  H2 = 7.90</p> <p><b>Geschoss</b></p> <p>G1 <sup>1)</sup> = 7.26                  G2 =                  F =                  L3+G <sup>1)</sup> = 41.40</p> <p><b>Drücke (Energien)</b></p> <p><b>Mech. elektr. Wandler</b></p> <p>Pmax = 2800 bar                  PK = 3220 bar                  PE = 3500 bar                  M = 17.50                  EE = 1715 Joule</p> <p><b>Verschiedene Daten</b></p> <p>Fe <sup>1)</sup> = 0.15                  delta L = 0.09</p>		<p><b>Längen</b></p> <p>L1 * = 26.54                  L2 * = 29.03                  L3 <sup>1)</sup> = 33.94</p> <p><b>Stoßboden</b></p> <p>R = 1.27                  R1 = 10.05                  R2 =                  R3 =                  r =</p> <p><b>Pulverkammer</b></p> <p>E = 3.04                  P1 <sup>1)</sup> = 9.98                  P2 * = 9.55</p> <p><b>Schulterkonus</b></p> <p>alpha <sup>1)</sup> = 34°59'46"                  S = 41.69                  r1 max =                  r2 =</p> <p><b>Hülsenhals</b></p> <p>H1 * = 7.98                  H2 <sup>1)</sup> = 7.93</p> <p><b>Geschossübergang</b></p> <p>G1 <sup>1)</sup>* = 7.29                  G <sup>1)</sup>* = 8.07                  alpha1 = 90°                  h * = 0.32                  s =                  i <sup>1)</sup> = 1°08'45"                  w =</p> <p><b>Lauf</b></p> <p>F <sup>1)</sup>* = 6.98                  Z <sup>1)</sup> = 7.23</p> <p><b>Züge</b></p> <p>b = 3.60                  N = 4                  u = 401.00                  Q = 40.15 mm<sup>2</sup></p>	
Maßstab 1:1				
Maße in << mm >> Maße und Toleranzen für Messläufe siehe Anhang CR 1.		Bemerkungen: 1) Kontrolle aus Sicherheitsgründen * Grundmaße		

<b>C.I.P.</b>	<b>7 x 44 Penna</b>	TAB.	I
		Datum	13-05-22
		Revision	
Ursprungsland: IT			
	<b>PATRONE MAXI</b>	<b>PATRONENLAGER MINI</b>	
	<p><b>Längen</b></p> <p>L1 <sup>1)</sup> = 35.00 -0.20                  L2 <sup>1)</sup> = 38.67 -0.20                  L3 <sup>1)</sup> = 44.50                  L4 =                  L5 =                  L6 = 60.00</p> <p><b>Hülsenboden</b></p> <p>R = 1.14                  R1 = 9.60                  R3 =                  E = 3.13                  E1 = 8.43                  e min = 0.76                  delta = 25°                  f = 0.45                  beta = 35°</p> <p><b>Pulverkammer</b></p> <p>P1 = 9.58                  P2 <sup>1)</sup>* = 9.03 -0.20</p> <p><b>Schulterkonus</b></p> <p>alpha * = 22°02'56"                  S * = 58.17                  r1 min = 0.60                  r2 = 2.50</p> <p><b>Hülsenhals</b></p> <p>H1 * = 7.60                  H2 <sup>1)</sup> = 7.60</p> <p><b>Geschoss</b></p> <p>G1 <sup>1)</sup> = 7.04                  G2 =                  F =                  L3+G <sup>1)</sup> = 59.66</p> <p><b>Drücke (Energien)</b></p> <p><b>Mech. elektr. Wandler</b></p> <p>Pmax = 4400 bar                  PK = 5060 bar                  PE = 5500 bar                  M = 25.00                  EE = 2000 Joule</p> <p><b>Verschiedene Daten</b></p> <p>Fe <sup>1)3)</sup> = 0.10                  delta L = 0.10</p>	<p><b>Längen</b></p> <p>L1 = 34.90                  L2 = 38.67                  L3 <sup>1)</sup> = 44.40</p> <p><b>Stoßboden</b></p> <p>R =                  R1 = 9.63                  R2 =                  R3 =                  r =</p> <p><b>Pulverkammer</b></p> <p>E = 3.13                  P1 <sup>1)</sup> = 9.61                  P2 * = 9.03</p> <p><b>Schulterkonus</b></p> <p>alpha <sup>1)</sup>* = 21°11'03"                  S * = 59.04                  r1 max = 0.60                  r2 = 2.50</p> <p><b>Hülsenhals</b></p> <p>H1 * = 7.62                  H2 <sup>1)</sup> = 7.62</p> <p><b>Geschossübergang</b></p> <p>G1 <sup>1)</sup>* = 7.04                  G <sup>1)</sup> = 15.16                  alpha l = 180°                  h =                  s * = 10.00                  i <sup>1)</sup>* = 0°59'57"                  w =</p> <p><b>Lauf</b></p> <p>F <sup>1)</sup>* = 6.86                  Z <sup>1)</sup> = 7.03</p> <p><b>Züge</b></p> <p>b = 0.85                  N = 6                  u = 254.00                  Q = 37.40 mm<sup>2</sup></p>	
Maßstab 1.2:1			
Maße in << mm >> Maße und Toleranzen für Messläufe siehe Anhang CR 1.		Bemerkungen: 1) Kontrolle aus Sicherheitsgründen 3) Verschlussabstand an Schulter * Grundmaße	





C.I.P.	7-47 GS		TAB.	I
	Ursprungsland: IT		Datum	13-05-22
			Revision	
	<b>PATRONE MAXI</b> <b>Längen</b> L1 <sup>1)</sup> = 35.68 -0.20 L2 <sup>1)</sup> = 38.90 -0.20 L3 <sup>1)</sup> = 47.00 L4 = L5 = L6 = 71.00 <b>Hülsenboden</b> R = 1.37 R1 = 12.01 R3 = E = 3.84 E1 = 10.39 e min = 1.40 delta = 36° f = 0.38 beta = 45° <b>Pulverkammer</b> P1 = 11.95 P2 <sup>1)</sup> * = 11.59 -0.20 <b>Schulterkonus</b> alpha * = 61°21' S * = 45.45 r1 min = 1.00 r2 = 1.50 <b>Hülsenhals</b> H1 * = 7.77 H2 <sup>1)</sup> = 7.77 <b>Geschoss</b> G1 * = 7.06 G2 = F = 6.86 L3+G <sup>1)</sup> = 52.57 <b>Drücke (Energien)</b> <b>Mech. elektr. Wandler</b> Pmax = 4350 bar PK = 5003 bar PE = 5438 bar M = 25.00 EE = 3600 Joule <b>Verschiedene Daten</b> Fe <sup>1)3)</sup> = 0.10 delta L = 0.09		<b>PATRONENLAGER MINI</b> <b>Längen</b> L1 = 35.57 L2 = 38.75 L3 <sup>1)</sup> = 47.26 <b>Stoßboden</b> R = R1 = 12.04 R2 = R3 = r = <b>Pulverkammer</b> E = 3.85 P1 <sup>1)</sup> = 11.99 P2 * = 11.63 <b>Schulterkonus</b> alpha <sup>1)</sup> * = 61°34'57" S * = 45.33 r1 max = 0.75 r2 = 1.75 <b>Hülsenhals</b> H1 * = 7.84 H2 <sup>1)</sup> = 7.80 <b>Geschossübergang</b> G1 <sup>1)</sup> * = 7.06 G = 5.57 alpha l = 90° h = 0.37 s * = 1.64 i <sup>1)</sup> * = 1°27'27" w = <b>Lauf</b> F <sup>1)</sup> * = 6.86 Z <sup>1)</sup> = 7.04 <b>Züge</b> b = 4.06 N = 4 u = 280.00 Q = 38.52 mm <sup>2</sup>	
Maßstab 1.14:1  Maße in << mm >> Maße und Toleranzen für Messläufe siehe Anhang CR 1.		Bemerkungen: 1) Kontrolle aus Sicherheitsgründen 3) Verschlussabstand an Schulter * Grundmaße		

<b>C.I.P.</b>	<b>7 mm - 08 Rem.</b>	TAB. <b>I</b>
		Datum <b>84-06-14</b>
		Revision <b>02-05-15</b>
Ursprungsland: US		
	<b>PATRONE MAXI</b>	<b>PATRONENLAGER MINI</b>
	<p><b>Längen</b></p> <p>L1<sup>1)</sup> = 39.62 -0.20                  L2<sup>1)</sup> = 44.47 -0.20                  L3<sup>1)</sup> = 51.69                  L4 =                  L5 =                  L6 = 71.12</p> <p><b>Hülsenboden</b></p> <p>R = 1.37                  R1 = 12.01                  R3 =                  E = 3.85                  E1 = 10.39                  e min = 1.40                  delta = 36°                  f = 0.38                  beta = 35°</p> <p><b>Pulverkammer</b></p> <p>P1 = 11.96                  P2<sup>1)*</sup> = 11.53 -0.20</p> <p><b>Schulterkonus</b></p> <p>alpha* = 40°                  S* = 55.46                  r1 min = 0.76                  r2 = 3.18</p> <p><b>Hülsenhals</b></p> <p>H1* = 8.00                  H2<sup>1)</sup> = 8.00</p> <p><b>Geschoss</b></p> <p>G1<sup>1)</sup> = 7.23                  G2 =                  F =                  L3+G<sup>1)</sup> = 56.93</p> <p><b>Drücke (Energien)</b></p> <p><b>Mech. elektr. Wandler</b></p> <p>Pmax = 4150 bar                  PK = 4773 bar                  PE = 5190 bar                  M = 25.00                  EE = 3720 Joule</p> <p><b>Verschiedene Daten</b></p> <p>Fe<sup>1)</sup> = 0.10                  delta L = 0.10</p>	<p><b>Längen</b></p> <p>L1 = 39.48                  L2 = 44.30                  L3<sup>1)</sup> = 51.94</p> <p><b>Stoßboden</b></p> <p>R =                  R1 = 12.03                  R2 =                  R3 =                  r =</p> <p><b>Pulverkammer</b></p> <p>E = 3.85                  P1<sup>1)</sup> = 11.99                  P2* = 11.56</p> <p><b>Schulterkonus</b></p> <p>alpha<sup>1)*</sup> = 40°                  S* = 55.36                  r1 max = 0.76                  r2 = 3.81</p> <p><b>Hülsenhals</b></p> <p>H1* = 8.05                  H2<sup>1)</sup> = 8.03</p> <p><b>Geschossübergang</b></p> <p>G1<sup>1)*</sup> = 7.23                  G<sup>1)</sup> = 5.24                  alpha1* = 90°                  h = 0.40                  s = 3.43                  i<sup>1)*</sup> = 3°                  w =</p> <p><b>Lauf</b></p> <p>F<sup>1)*</sup> = 7.04                  Z<sup>1)</sup> = 7.21</p> <p><b>Züge</b></p> <p>b = 2.79                  N = 6                  u = 241.00                  Q = 40.39 mm<sup>2</sup></p>
Maßstab 1:1		
Maße in << mm >> Maße und Toleranzen für Messläufe siehe Anhang CR 1.		Bemerkungen: 1) Kontrolle aus Sicherheitsgründen * Grundmaße



C.I.P.	7 mm Blaser Mag.	TAB.	I
		Datum	09-05-05
		Revision	
Ursprungsland: SE			
	<b>PATRONE MAXI</b>		<b>PATRONENLAGER MINI</b>
	<b>Längen</b> L1 <sup>1)</sup> = 47.24 -0.20 L2 <sup>1)</sup> = 51.65 -0.20 L3 <sup>1)</sup> = 59.70 L4 = L5 = L6 = 80.00 <b>Hülsenboden</b> R = 1.37 R1 = 13.59 R3 = E = 3.61 E1 = 12.19 e min = 1.42 delta = 45° f = 0.30 beta = 35° <b>Pulverkammer</b> P1 = 13.84 P2 <sup>1)</sup> * = 13.09 -0.20 <b>Schulterkonus</b> alpha * = 60° S * = 58.58 r1 min = 1.50 r2 = 2.00 <b>Hülsenhals</b> H1 * = 8.00 H2 <sup>1)</sup> = 8.00 <b>Geschoss</b> G1 <sup>1)</sup> = 7.22 G2 = F = L3+G <sup>1)</sup> = 68.96 <b>Drücke (Energien)</b> <b>Mech. elektr. Wandler</b> Pmax = 4200 bar PK = 4830 bar PE = 5250 bar M = 25.00 EE = 4585 Joule <b>Verschiedene Daten</b> Fe <sup>1)3)</sup> = 0.10 delta L =	<b>Längen</b> L1 = 47.22 L2 = 51.59 L3 <sup>1)</sup> = 60.00 <b>Stoßboden</b> R = 1.37 R1 = 13.92 R2 = R3 = r = <b>Pulverkammer</b> E = 3.61 P1 <sup>1)</sup> = 13.87 P2 * = 13.12 <b>Schulterkonus</b> alpha <sup>1)</sup> * = 60° S * = 58.58 r1 max = 1.50 r2 = 2.00 <b>Hülsenhals</b> H1 * = 8.07 H2 <sup>1)</sup> = 8.02 <b>Geschossübergang</b> G1 <sup>1)</sup> * = 7.23 G <sup>1)</sup> = 9.26 alpha1 = 90° h = 0.40 s * = 2.00 i <sup>1)</sup> * = 0°45' w = <b>Lauf</b> F <sup>1)</sup> * = 7.04 Z <sup>1)</sup> = 7.21 <b>Züge</b> b = 4.06 N = 4 u = 254.00 Q = 40.39 mm <sup>2</sup>	
Maßstab 1:1			
Maße in << mm >> Maße und Toleranzen für Messläufe siehe Anhang CR 1.	Bemerkungen: 1) Kontrolle aus Sicherheitsgründen 3) Verschlussabstand an Schulter * Grundmaße		

<b>C.I.P.</b>	<b>7 mm BR Rem.</b>	<b>TAB.</b>	<b>I</b>
		<b>Datum</b>	<b>94-03-01</b>
		<b>Revision</b>	<b>02-05-15</b>
Ursprungsland: US			
	<b>PATRONE MAXI</b>	<b>PATRONENLAGER MINI</b>	
	<p><b>Längen</b></p> <p>L1<sup>1)</sup> = 27.30 -0.20                  L2<sup>1)</sup> = 30.61 -0.20                  L3<sup>1)</sup> = 38.61                  L4 =                  L5 =                  L6 = 54.42</p> <p><b>Hülsenboden</b></p> <p>R = 1.37                  R1 = 12.01                  R3 =                  E = 3.85                  E1 = 10.39                  e min = 1.40                  delta = 36°                  f = 0.46                  beta = 35°</p> <p><b>Pulverkammer</b></p> <p>P1 = 11.96                  P2<sup>1)*</sup> = 11.68 -0.20</p> <p><b>Schulterkonus</b></p> <p>alpha* = 60°                  S* = 37.42                  r1 min = 0.64                  r2 = 1.27</p> <p><b>Hülsenhals</b></p> <p>H1* = 7.86                  H2<sup>1)</sup> = 7.84</p> <p><b>Geschoss</b></p> <p>G1<sup>1)</sup> = 7.23                  G2 =                  F =                  L3+G<sup>1)</sup> = 43.62</p> <p><b>Drücke (Energien)</b></p> <p><b>Mech. elektr. Wandler</b></p> <p>Pmax = 4050 bar                  PK = 4658 bar                  PE = 5060 bar                  M = 17.50                  EE = 3150 Joule</p> <p><b>Verschiedene Daten</b></p> <p>Fe<sup>1)</sup> = 0.10                  delta L = 0.08</p>	<p><b>Längen</b></p> <p>L1 = 27.20                  L2 = 30.52                  L3<sup>1)</sup> = 38.86</p> <p><b>Stoßboden</b></p> <p>R =                  R1 = 12.04                  R2 =                  R3 =                  r =</p> <p><b>Pulverkammer</b></p> <p>E = 3.85                  P1<sup>1)</sup> = 11.99                  P2* = 11.71</p> <p><b>Schulterkonus</b></p> <p>alpha<sup>1)*</sup> = 60°                  S* = 37.34                  r1 max = 0.64                  r2 = 1.91</p> <p><b>Hülsenhals</b></p> <p>H1* = 7.87                  H2<sup>1)</sup> = 7.85</p> <p><b>Geschossübergang</b></p> <p>G1<sup>1)*</sup> = 7.23                  G<sup>1)</sup> = 5.01                  alpha1* = 90°                  h = 0.31                  s = 3.20                  i<sup>1)*</sup> = 3°                  w =</p> <p><b>Lauf</b></p> <p>F<sup>1)*</sup> = 7.04                  Z<sup>1)</sup> = 7.21</p> <p><b>Züge</b></p> <p>b = 2.79                  N = 6                  u = 241.30                  Q = 40.39 mm<sup>2</sup></p>	
Maßstab 1:1			
Maße in << mm >> Maße und Toleranzen für Messläufe siehe Anhang CR 1.		Bemerkungen: 1) Kontrolle aus Sicherheitsgründen * Grundmaße	

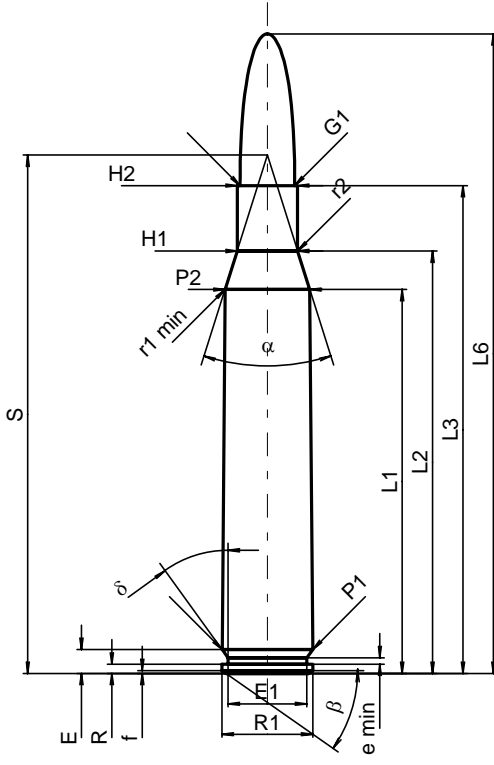
C.I.P.	7 mm Exp. Rem. Ursprungsland: US	TAB.	I	
		Datum	84-06-14	
		Revision	02-05-15	
	<b>PATRONE MAXI</b>		<b>PATRONENTLAGER MINI</b>	
	<b>Längen</b> L1 <sup>1)</sup> = 50.78 -0.20 L2 <sup>1)</sup> = 55.87 -0.20 L3 <sup>1)</sup> = 64.52 L4 = L5 = L6 = 84.58		<b>Längen</b> L1 = 50.61 L2 = 55.70 L3 <sup>1)</sup> = 65.02	
<b>Hülsenboden</b> R = 1.24 R1 = 12.01 R3 = E = 3.17 E1 = 10.39 e min = 0.84 delta = 36° f = 0.38 beta = 35°		<b>Stoßboden</b> R = R1 = 12.06 R2 = R3 = r =		
<b>Pulverkammer</b> P1 = 11.97 P2 <sup>1)*</sup> = 11.21 -0.20		<b>Pulverkammer</b> E = 3.17 P1 <sup>1)</sup> = 12.00 P2* = 11.23		
<b>Schulterkonus</b> alpha* = 35° S* = 68.56 r1 min = 0.64 r2 = 2.54		<b>Schulterkonus</b> alpha <sup>1)*</sup> = 34°30' S* = 68.69 r1 max = 0.64 r2 = 3.18		
<b>Hülsehals</b> H1* = 8.00 H2 <sup>1)</sup> = 8.00		<b>Hülsehals</b> H1* = 8.07 H2 <sup>1)</sup> = 8.02		
<b>Geschoss</b> G1 <sup>1)</sup> = 7.23 G2 = F = L3+G <sup>1)</sup> = 69.27		<b>Geschossübergang</b> G1 <sup>1)*</sup> = 7.25 G <sup>1)</sup> = 4.75 alpha1* = 90° h = 0.39 s = i <sup>1)*</sup> = 1°22'34" w =		
<b>Drücke (Energien)</b> <b>Mech. elektr. Wandler</b> Pmax = 4050 bar PK = 4658 bar PE = 5060 bar M = 25.00 EE = 3930 Joule		<b>Lauf</b> F <sup>1)*</sup> = 7.04 Z <sup>1)</sup> = 7.21		
<b>Züge</b> b = 2.79 N = 6 u = 241.00 Q = 40.39 mm <sup>2</sup>				
<b>Verschiedene Daten</b> Fe <sup>1)</sup> = 0.10 delta L = 0.14				
Maßstab 1:1  Maße in << mm >> Maße und Toleranzen für Messläufe siehe Anhang CR 1.		Bemerkungen: 1) Kontrolle aus Sicherheitsgründen * Grundmaße		

<b>C.I.P.</b>	<b>7 mm KM</b>		<b>TAB.</b>	<b>I</b>
	Ursprungsland: DE		Datum	99-09-01
			Revision	11-05-25
	<b>PATRONE MAXI</b>		<b>PATRONENLAGER MINI</b>	
	<p><b>Längen</b></p> <p>L1 <sup>1)</sup>* = 54.90 -0.20</p> <p>L2 <sup>1)</sup>* = 60.72 -0.20</p> <p>L3 <sup>1)</sup> = 69.20</p> <p>L4 =</p> <p>L5 =</p> <p>L6 = 93.50</p> <p><b>Hülsenboden</b></p> <p>R = 1.52</p> <p>R1 = 14.93</p> <p>R3 =</p> <p>E = 3.12</p> <p>E1 = 13.24</p> <p>e min = 0.90</p> <p>delta = 50°</p> <p>f = 0.50</p> <p>beta = 45°</p> <p><b>Pulverkammer</b></p> <p>P1 = 14.91</p> <p>P2 <sup>1)</sup>* = 13.82 -0.20</p> <p><b>Schulterkonus</b></p> <p>alpha = 52°01'19"</p> <p>S = 69.05</p> <p>r1 min =</p> <p>r2 = 2.00</p> <p><b>Hülsenhals</b></p> <p>H1 * = 8.14</p> <p>H2 <sup>1)</sup> = 8.12</p> <p><b>Geschoss</b></p> <p>G1 <sup>1)</sup> = 7.23</p> <p>G2 =</p> <p>F =</p> <p>L3+G <sup>1)</sup> = 76.32</p> <p><b>Drücke (Energien)</b></p> <p><b>Mech. elektr. Wandler</b></p> <p>Pmax = 4400 bar</p> <p>PK = 5060 bar</p> <p>PE = 5500 bar</p> <p>M = 25.00</p> <p>EE = 5670 Joule</p> <p><b>Verschiedene Daten</b></p> <p>Fe <sup>1)3)</sup> = 0.10</p> <p>delta L =</p>		<p><b>Längen</b></p> <p>L1 * = 54.87</p> <p>L2 * = 60.70</p> <p>L3 <sup>1)</sup> = 69.45</p> <p><b>Stoßboden</b></p> <p>R =</p> <p>R1 = 15.03</p> <p>R2 =</p> <p>R3 =</p> <p>r =</p> <p><b>Pulverkammer</b></p> <p>E = 3.12</p> <p>P1 <sup>1)</sup> = 14.96</p> <p>P2 * = 13.85</p> <p><b>Schulterkonus</b></p> <p>alpha <sup>1)</sup> = 52°01'27"</p> <p>S = 69.06</p> <p>r1 max =</p> <p>r2 = 2.50</p> <p><b>Hülsenhals</b></p> <p>H1 * = 8.16</p> <p>H2 <sup>1)</sup> = 8.14</p> <p><b>Geschossübergang</b></p> <p>G1 <sup>1)</sup>* = 7.23</p> <p>G <sup>1)</sup>* = 7.12</p> <p>alpha1 = 90°37'59"</p> <p>h = 0.45</p> <p>s * = 3.95</p> <p>i <sup>1)</sup> = 1°43'</p> <p>w =</p> <p><b>Lauf</b></p> <p>F <sup>1)</sup>* = 7.04</p> <p>Z <sup>1)</sup> = 7.21</p> <p><b>Züge</b></p> <p>b = 2.79</p> <p>N = 6</p> <p>u = 216.00</p> <p>Q = 40.39 mm<sup>2</sup></p>	
<p>Maßstab 1:1.17</p> <p>Maße in &lt;&lt; mm &gt;&gt;</p> <p>Maße und Toleranzen für Messläufe siehe Anhang CR 1.</p>		<p>Bemerkungen: 1) Kontrolle aus Sicherheitsgründen 3) Verschlussabstand an Schulter * Grundmaße</p>		

<b>C.I.P.</b>	<b>7 mm Rem. SA Ultra Mag.</b>	<b>TAB.</b>	<b>I</b>
		<b>Datum</b>	<b>02-03-01</b>
		<b>Revision</b>	<b>04-09-27</b>
Ursprungsland: US			
	<b>PATRONE MAXI</b>	<b>PATRONENLAGER MINI</b>	
	<p><b>Längen</b></p> <p>L1<sup>1)</sup> = 39.07 -0.20                      L2<sup>1)</sup> = 43.79 -0.20                      L3<sup>1)</sup> = 51.69                      L4 =                      L5 =                      L6 = 71.76</p> <p><b>Hülsenboden</b></p> <p>R = 1.27                      R1 = 13.56                      R3 =                      E = 3.75                      E1 = 12.07                      e min = 0.94                      delta = 32°                      f = 0.41                      beta = 35°</p> <p><b>Pulverkammer</b></p> <p>P1 = 14.00                      P2<sup>1)*</sup> = 13.58 -0.20</p> <p><b>Schulterkonus</b></p> <p>alpha* = 60°                      S* = 50.83                      r1 min =                      r2 = 3.18</p> <p><b>Hülsenhals</b></p> <p>H1* = 8.13                      H2<sup>1)</sup> = 8.13</p> <p><b>Geschoss</b></p> <p>G1<sup>1)</sup> = 7.23                      G2 = 7.04                      F =                      L3+G<sup>1)</sup> = 59.88</p> <p><b>Drücke (Energien)</b></p> <p><b>Mech. elektr. Wandler</b></p> <p>Pmax = 4400 bar                      PK = 5060 bar                      PE = 5500 bar                      M = 25.00                      EE = 4500 Joule</p> <p><b>Verschiedene Daten</b></p> <p>Fe = 0.10                      delta L = 0.10</p>	<p><b>Längen</b></p> <p>L1 = 38.95                      L2 = 43.65                      L3<sup>1)</sup> = 51.94</p> <p><b>Stoßboden</b></p> <p>R =                      R1 = 14.05                      R2 =                      R3 =                      r =</p> <p><b>Pulverkammer</b></p> <p>E = 3.75                      P1<sup>1)</sup> = 14.01                      P2* = 13.61</p> <p><b>Schulterkonus</b></p> <p>alpha<sup>1)*</sup> = 60°                      S* = 50.74                      r1 max =                      r2 = 3.18</p> <p><b>Hülsenhals</b></p> <p>H1* = 8.18                      H2<sup>1)</sup> = 8.15</p> <p><b>Geschossübergang</b></p> <p>G1<sup>1)*</sup> = 7.23                      G<sup>1)</sup> = 8.19                      alpha1* = 90°                      h = 0.46                      s = 2.75                      i<sup>1)*</sup> = 1°                      w =</p> <p><b>Lauf</b></p> <p>F<sup>1)*</sup> = 7.04                      Z<sup>1)</sup> = 7.21</p> <p><b>Züge</b></p> <p>b = 2.79                      N = 6                      u = 254.00                      Q = 40.39 mm<sup>2</sup></p>	
Maßstab 1:1			
Maße in << mm >> Maße und Toleranzen für Messläufe siehe Anhang CR 1.		Bemerkungen: 1) Kontrolle aus Sicherheitsgründen * Grundmaße	

<b>C.I.P.</b>	<b>7 mm Rem. Ultra Mag.</b>	TAB.	I
		Datum	02-01-22
		Revision	02-05-15
Ursprungsland: US			
	<b>PATRONE MAXI</b>	<b>PATRONENLAGER MINI</b>	
	<p><b>Längen</b></p> <p>L1<sup>1)</sup> = 60.64 -0.20                  L2<sup>1)</sup> = 65.10 -0.20                  L3<sup>1)</sup> = 72.39                  L4 =                  L5 =                  L6 = 91.44</p> <p><b>Hülsenboden</b></p> <p>R = 1.27                  R1 = 13.56                  R3 =                  E = 3.75                  E1 = 12.07                  e min = 0.94                  δ = 32°                  f = 0.41                  β = 35°</p> <p><b>Pulverkammer</b></p> <p>P1 = 13.99                  P2<sup>1)*</sup> = 13.33 -0.20</p> <p><b>Schulterkonus</b></p> <p>α* = 60°                  S* = 72.18                  r1 min = 0.76                  r2 = 3.18</p> <p><b>Hülsenhals</b></p> <p>H1* = 8.18                  H2<sup>1)</sup> = 8.18</p> <p><b>Geschoss</b></p> <p>G1<sup>1)</sup> = 7.23                  G2 =                  F =                  L3+G<sup>1)</sup> = 88.20</p> <p><b>Drücke (Energien)</b></p> <p><b>Mech. elektr. Wandler</b></p> <p>Pmax = 4400 bar                  PK = 5060 bar                  PE = 5500 bar                  M = 25.00                  EE = 5250 Joule</p> <p><b>Verschiedene Daten</b></p> <p>Fe<sup>1)</sup> = 0.10                  delta L = 0.10</p>	<p><b>Längen</b></p> <p>L1 = 60.51                  L2 = 64.96                  L3<sup>1)</sup> = 72.64</p> <p><b>Stoßboden</b></p> <p>R =                  R1 = 14.05                  R2 =                  R3 =                  r =</p> <p><b>Pulverkammer</b></p> <p>E = 3.75                  P1<sup>1)</sup> = 14.02                  P2* = 13.36</p> <p><b>Schulterkonus</b></p> <p>α<sup>1)*</sup> = 60°                  S* = 72.08                  r1 max = 0.76                  r2 = 3.18</p> <p><b>Hülsenhals</b></p> <p>H1* = 8.23                  H2<sup>1)</sup> = 8.20</p> <p><b>Geschossübergang</b></p> <p>G1<sup>1)*</sup> = 7.23                  G<sup>1)</sup> = 15.81                  α1 = 90°                  h = 0.49                  s* = 10.65                  i<sup>1)*</sup> = 1°                  w =</p> <p><b>Lauf</b></p> <p>F<sup>1)*</sup> = 7.04                  Z<sup>1)</sup> = 7.21</p> <p><b>Züge</b></p> <p>b = 2.79                  N = 6                  u = 241.30                  Q = 40.34 mm<sup>2</sup></p>	
Maßstab 1:1			
Maße in << mm >> Maße und Toleranzen für Messläufe siehe Anhang CR 1.	Bemerkungen: 1) Kontrolle aus Sicherheitsgründen * Grundmaße		

<b>C.I.P.</b>	<b>7 mm SE v. H.</b>		<b>TAB.</b>	<b>I</b>
	Ursprungsland: DE		<b>Datum</b>	<b>84-06-14</b>
			<b>Revision</b>	<b>02-05-15</b>
	<b>PATRONE MAXI</b>		<b>PATRONENLAGER MINI</b>	
	<p><b>Längen</b></p> <p>L1 <sup>1)</sup>* = 53.60 -0.20                      L2 <sup>1)</sup>* = 57.52 -0.20                      L3 <sup>1)</sup> = 66.00                      L4 =                      L5 =                      L6 = 84.00</p> <p><b>Hülsenboden</b></p> <p>R = 1.30                      R1 = 13.00                      R3 =                      E = 3.70                      E1 = 11.50                      e min = 1.00                      delta = 40°                      f = 0.30                      beta = 45°</p> <p><b>Pulverkammer</b></p> <p>P1 = 13.85                      P2 <sup>1)</sup>* = 12.70 -0.20</p> <p><b>Schulterkonus</b></p> <p>alpha = 60°02'21"                      S = 64.59                      r1 min = 0.50                      r2 = 0.50</p> <p><b>Hülsenhals</b></p> <p>H1* = 8.17                      H2 <sup>1)</sup> = 8.17</p> <p><b>Geschoss</b></p> <p>G1 <sup>1)</sup> = 7.24                      G2 =                      F =                      L3+G <sup>1)</sup> = 81.00</p> <p><b>Drücke (Energien)</b>  <b>Mech. elektr. Wandler</b></p> <p>Pmax = 4400 bar                      PK = 5060 bar                      PE = 5500 bar                      M = 25.00                      EE = 4525 Joule</p> <p><b>Verschiedene Daten</b></p> <p>Fe <sup>1)</sup> = 0.10                      delta L =</p>		<p><b>Längen</b></p> <p>L1* = 53.56                      L2* = 57.47                      L3 <sup>1)</sup> = 66.50</p> <p><b>Stoßboden</b></p> <p>R = 1.30                      R1 = 13.05                      R2 =                      R3 =                      r =</p> <p><b>Pulverkammer</b></p> <p>E = 3.70                      P1 <sup>1)</sup> = 13.88                      P2* = 12.73</p> <p><b>Schulterkonus</b></p> <p>alpha <sup>1)</sup> = 60°03'23"                      S = 64.57                      r1 max = 0.50                      r2 = 0.50</p> <p><b>Hülsenhals</b></p> <p>H1* = 8.21                      H2 <sup>1)</sup> = 8.20</p> <p><b>Geschossübergang</b></p> <p>G1 <sup>1)</sup>* = 7.28                      G <sup>1)</sup>* = 15.00                      alpha1 = 180°                      h =                      s =                      i <sup>1)</sup> = 0°34'22"                      w =</p> <p><b>Lauf</b></p> <p>F <sup>1)</sup>* = 6.98                      Z <sup>1)</sup> = 7.24</p> <p><b>Züge</b></p> <p>b = 4.00                      N = 4                      u = 260.00                      Q = 40.47 mm<sup>2</sup></p>	
Maßstab 1:1				
Maße in << mm >> Maße und Toleranzen für Messläufe siehe Anhang CR 1.		Bemerkungen: 1) Kontrolle aus Sicherheitsgründen * Grundmaße		

<b>C.I.P.</b>	<b>7 mm Win. Short Mag.</b>	TAB.	I
		Datum	02-01-22
		Revision	11-05-25
Ursprungsland: US			
	<b>PATRONE MAXI</b>	<b>PATRONENLAGER MINI</b>	
	<p><b>Längen</b></p> <p>L1 <sup>1)</sup> = 43.23 -0.20                  L2 <sup>1)</sup> = 47.17 -0.20                  L3 <sup>1)</sup> = 53.34                  L4 =                  L5 =                  L6 = 72.64</p> <p><b>Hülsenboden</b></p> <p>R = 1.37                  R1 = 13.59                  R3 =                  E = 3.35                  E1 = 12.19                  e min = 1.02                  delta = 45°                  f = 0.36                  beta = 35°</p> <p><b>Pulverkammer</b></p> <p>P1 = 14.12                  P2 <sup>1)</sup>* = 13.66 -0.20</p> <p><b>Schulterkonus</b></p> <p>alpha * = 70°                  S * = 52.99                  r1 min = 1.27                  r2 = 2.54</p> <p><b>Hülsenhals</b></p> <p>H1 * = 8.15                  H2 <sup>1)</sup> = 8.15</p> <p><b>Geschoss</b></p> <p>G1 <sup>1)</sup> = 7.23                  G2 =                  F =                  L3+G <sup>1)</sup> = 58.56</p> <p><b>Drücke (Energien)</b></p> <p><b>Mech. elektr. Wandler</b></p> <p>Pmax = 4400 bar                  PK = 5060 bar                  PE = 5500 bar                  M = 25.00                  EE = 4830 Joule</p> <p><b>Verschiedene Daten</b></p> <p>Fe <sup>1)3)</sup> = 0.10                  delta L = 0.10</p>	<p><b>Längen</b></p> <p>L1 = 43.10                  L2 = 47.02                  L3 <sup>1)</sup> = 53.59</p> <p><b>Stoßboden</b></p> <p>R =                  R1 = 14.19                  R2 =                  R3 =                  r =</p> <p><b>Pulverkammer</b></p> <p>E = 3.35                  P1 <sup>1)</sup> = 14.15                  P2 * = 13.69</p> <p><b>Schulterkonus</b></p> <p>alpha <sup>1)</sup>* = 70°                  S * = 52.88                  r1 max = 1.27                  r2 = 3.05</p> <p><b>Hülsenhals</b></p> <p>H1 * = 8.20                  H2 <sup>1)</sup> = 8.18</p> <p><b>Geschossübergang</b></p> <p>G1 <sup>1)</sup>* = 7.29                  G <sup>1)</sup> = 5.22                  alpha1 = 90°                  h = 0.45                  s =                  i <sup>1)</sup>* = 1°30'                  w =</p> <p><b>Lauf</b></p> <p>F <sup>1)</sup>* = 7.04                  Z <sup>1)</sup> = 7.21</p> <p><b>Züge</b></p> <p>b = 2.79                  N = 6                  u = 241.00                  Q = 40.39 mm<sup>2</sup></p>	
<p>Maßstab 1.0:1</p> <p style="text-align: center;">Maße in &lt;&lt; mm &gt;&gt; Maße und Toleranzen für Messläufe siehe Anhang CR 1.</p>		<p>Bemerkungen: 1) Kontrolle aus Sicherheitsgründen 3) Verschlussabstand an Schulter * Grundmaße</p>	



<b>C.I.P.</b>	<b>7,21 Firebird</b>		<b>TAB.</b>	<b>I</b>
	Ursprungsland: FI		Datum	02-01-22
			Revision	08-09-23
	<b>PATRONE MAXI</b>		<b>PATRONENLAGER MINI</b>	
	<p><b>Längen</b></p> <p>L1 <sup>1)</sup>* = 58.70 -0.20</p> <p>L2 <sup>1)</sup>* = 63.91 -0.20</p> <p>L3 <sup>1)</sup> = 71.37</p> <p>L4 =</p> <p>L5 =</p> <p>L6 = 92.20</p> <p><b>Hülsenboden</b></p> <p>R = 1.65</p> <p>R1 = 14.76</p> <p>R3 =</p> <p>E = 3.99</p> <p>E1 = 12.95</p> <p>e min = 1.40</p> <p>δ = 45°</p> <p>f = 0.64</p> <p>β = 45°</p> <p><b>Pulverkammer</b></p> <p>P1 = 14.73</p> <p>P2 <sup>1)</sup>* = 14.22 -0.20</p> <p><b>Schulterkonus</b></p> <p>α = 60°01'59"</p> <p>S = 71.01</p> <p>r1 min = 1.57</p> <p>r2 = 3.18</p> <p><b>Hülsenhals</b></p> <p>H1 * = 8.20</p> <p>H2 <sup>1)</sup> = 8.15</p> <p><b>Geschoss</b></p> <p>G1 <sup>1)</sup> = 7.24</p> <p>G2 =</p> <p>F =</p> <p>L3+G <sup>1)</sup> = 76.46</p> <p><b>Drücke (Energien)</b></p> <p><b>Mech. elektr. Wandler</b></p> <p>Pmax = 4400 bar</p> <p>PK = 5060 bar</p> <p>PE = 5500 bar</p> <p>M = 25.00</p> <p>EE = 6375 Joule</p> <p><b>Verschiedene Daten</b></p> <p>Fe <sup>1)3)</sup> = 0.10</p> <p>delta L = 0.05</p>		<p><b>Längen</b></p> <p>L1 * = 58.58</p> <p>L2 * = 63.81</p> <p>L3 <sup>1)</sup> = 71.63</p> <p><b>Stoßboden</b></p> <p>R =</p> <p>R1 = 14.81</p> <p>R2 =</p> <p>R3 =</p> <p>r =</p> <p><b>Pulverkammer</b></p> <p>E = 3.99</p> <p>P1 <sup>1)</sup> = 14.78</p> <p>P2 * = 14.30</p> <p><b>Schulterkonus</b></p> <p>α <sup>1)</sup> = 60°00'27"</p> <p>S = 70.96</p> <p>r1 max = 1.57</p> <p>r2 = 3.18</p> <p><b>Hülsenhals</b></p> <p>H1 * = 8.26</p> <p>H2 <sup>1)</sup> = 8.20</p> <p><b>Geschossübergang</b></p> <p>G1 <sup>1)</sup>* = 7.24</p> <p>G <sup>1)</sup>* = 5.09</p> <p>α1 = 90°</p> <p>h = 0.48</p> <p>s * = 2.80</p> <p>i <sup>1)</sup> = 2°30'01"</p> <p>w =</p> <p><b>Lauf</b></p> <p>F <sup>1)</sup>* = 7.04</p> <p>Z <sup>1)</sup> = 7.21</p> <p><b>Züge</b></p> <p>b = 4.06</p> <p>N = 4</p> <p>u = 254.00</p> <p>Q = 40.39 mm<sup>2</sup></p>	
<p>Maßstab 1:1.15</p> <p>Maße in &lt;&lt; mm &gt;&gt;</p> <p>Maße und Toleranzen für Messläufe siehe Anhang CR 1.</p>		<p>Bemerkungen: 1) Kontrolle aus Sicherheitsgründen 3) Verschlussabstand an Schulter * Grundmaße</p>		

<b>C.I.P.</b>	<b>7,5 x 54 MAS</b>	TAB.	I
		Datum	07-05-14
		Revision	11-05-25
Ursprungsland: FR			
	<b>PATRONE MAXI</b>	<b>PATRONENLAGER MINI</b>	
	<p><b>Längen</b></p> <p>L1 <sup>1)</sup> = 42.79 -0.20                  L2 <sup>1)</sup> = 46.42 -0.20                  L3 <sup>1)</sup> = 54.00                  L4 =                  L5 =                  L6 = 76.00</p> <p><b>Hülsenboden</b></p> <p>R = 1.40                  R1 = 12.34                  R3 =                  E = 3.20                  E1 = 10.50                  e min = 0.80                  delta = 41°11'9"                  f = 0.30                  beta = 45°</p> <p><b>Pulverkammer</b></p> <p>P1 = 12.25                  P2 <sup>1)</sup>* = 11.30 -0.20</p> <p><b>Schulterkonus</b></p> <p>alpha * = 40°                  S * = 58.32                  r1 min = 2.00                  r2 = 3.20</p> <p><b>Hülsenhals</b></p> <p>H1 * = 8.66                  H2 <sup>1)</sup> = 8.62</p> <p><b>Geschoss</b></p> <p>G1 <sup>1)</sup> = 7.84                  G2 =                  F =                  L3+G <sup>1)</sup> = 67.58</p> <p><b>Drücke (Energien)</b></p> <p><b>Mech. elektr. Wandler</b></p> <p>Pmax = 3800 bar                  PK = 4370 bar                  PE = 4750 bar                  M = 25.00                  EE = 3250 Joule</p> <p><b>Verschiedene Daten</b></p> <p>Fe <sup>1)3)</sup> = 0.15                  delta L =</p>	<p><b>Längen</b></p> <p>L1 = 42.73                  L2 = 46.37                  L3 <sup>1)</sup> = 54.32</p> <p><b>Stoßboden</b></p> <p>R =                  R1 = 12.39                  R2 =                  R3 =                  r =</p> <p><b>Pulverkammer</b></p> <p>E = 3.20                  P1 <sup>1)</sup> = 12.30                  P2 * = 11.35</p> <p><b>Schulterkonus</b></p> <p>alpha <sup>1)</sup>* = 40°                  S * = 58.32                  r1 max = 2.00                  r2 = 3.20</p> <p><b>Hülsenhals</b></p> <p>H1 * = 8.70                  H2 <sup>1)</sup> = 8.66</p> <p><b>Geschossübergang</b></p> <p>G1 <sup>1)</sup>* = 7.90                  G <sup>1)</sup> = 13.58                  alpha1 * = 90°                  h = 0.38                  s =                  i <sup>1)</sup>* = 0°42'58"                  w =</p> <p><b>Lauf</b></p> <p>F <sup>1)</sup>* = 7.57                  Z <sup>1)</sup> = 7.85</p> <p><b>Züge</b></p> <p>b = 3.70                  N = 4                  u = 270.00                  Q = 47.17 mm<sup>2</sup></p>	
<p>Maßstab 1.02:1</p> <p style="text-align: center;">Maße in &lt;&lt; mm &gt;&gt; Maße und Toleranzen für Messläufe siehe Anhang CR 1.</p>		<p>Bemerkungen: 1) Kontrolle aus Sicherheitsgründen 3) Verschlussabstand an Schulter * Grundmaße</p>	

<b>C.I.P.</b>	<b>7,5 x 55 Suisse</b>	<b>TAB.</b>	<b>I</b>
		<b>Datum</b>	<b>84-06-14</b>
		<b>Revision</b>	<b>16-05-18</b>

Ursprungsland: CH

Alternative Namen: 7,5 x 55 Swiss

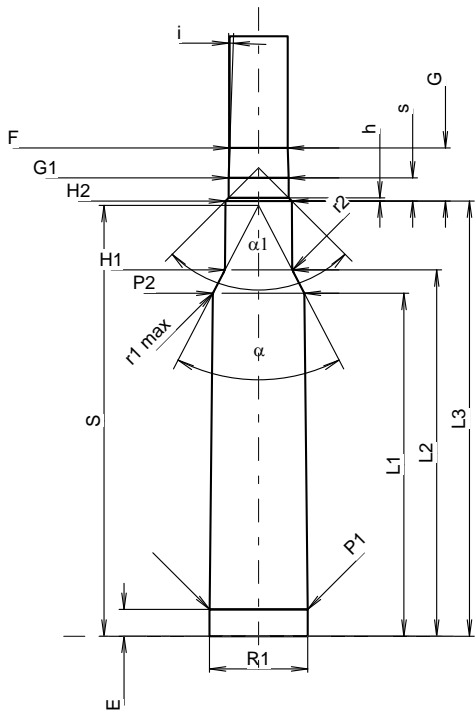
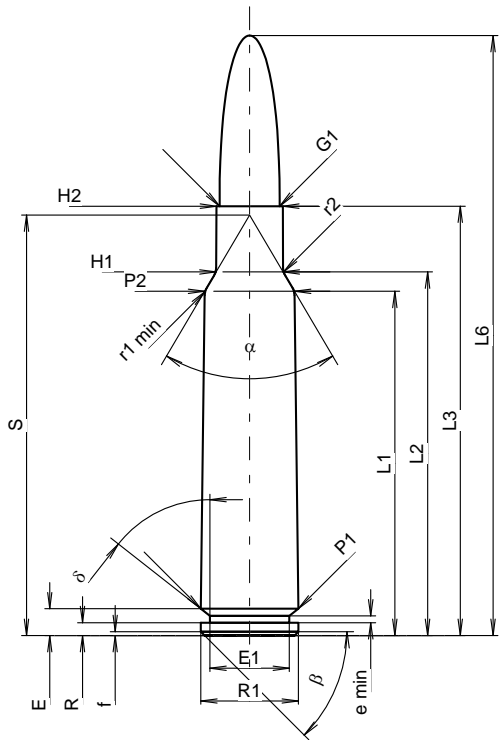

Maßstab 1.02:1

Maße in << mm >>  
Maße und Toleranzen für Messläufe  
siehe Anhang CR 1.

**PATRONE MAXI**

**Längen**

L1 <sup>1)</sup>	=	44.58	-0.20
L2 <sup>1)</sup>	=	47.08	-0.20
L3 <sup>1)</sup>	=	55.60	
L4	=		
L5	=		
L6	=	77.70	

**Hülsenboden**

R	=	1.65	
R1	=	12.65	
R3	=		
E	=	3.46	
E1	=	10.30	
e min	=	0.89	
delta	=	51°49'16"	
f	=	0.50	
beta	=	45°	

**Pulverkammer**

P1	=	12.64	
P2 <sup>1)</sup> *	=	11.63	-0.20

**Schulterkonus**

alpha *	=	61°	
S *	=	54.45	
r1 min	=	2.00	
r2	=	2.00	

**Hülsenhals**

H1 *	=	8.68	
H2 <sup>1)</sup>	=	8.58	

**Geschoss**

G1 <sup>1)</sup>	=	7.78	
G2	=		
F	=		
L3+G <sup>1)</sup>	=	62.47	

**Drücke (Energien)**

**Mech. elektr. Wandler**

Pmax	=	3800 bar	
PK	=	4370 bar	
PE	=	4750 bar	
M	=	25.00	
EE	=	3965 Joule	

**Verschiedene Daten**

Fe <sup>1)3)</sup>	=	0.15	
delta L	=		

**PATRONENLAGER MINI**

**Längen**

L1	=	44.40	
L2	=	47.43	
L3 <sup>1)</sup>	=	56.35	

**Stoßboden**

R	=	1.65	
R1	=	12.72	
R2	=		
R3	=		
r	=		

**Pulverkammer**

E	=	3.46	
P1 <sup>1)</sup>	=	12.69	
P2 *	=	11.85	

**Schulterkonus**

alpha <sup>1)</sup> *	=	55°	
S *	=	55.78	
r1 max	=	0.50	
r2	=	2.00	

**Hülsenhals**

H1 *	=	8.70	
H2 <sup>1)</sup>	=	8.60	

**Geschossübergang**

G1 <sup>1)</sup> *	=	7.78	
G <sup>1)</sup>	=	6.87	
alpha1 *	=	90°	
h	=	0.41	
s	=	3.00	
i <sup>1)</sup> *	=	2°	
w	=		

**Lauf**

F <sup>1)</sup> *	=	7.51	
Z <sup>1)</sup>	=	7.77	

**Züge**

b	=	3.75	
N	=	4	
u	=	270.00	
Q	=	46.33	mm <sup>2</sup>

Bemerkungen: 1) Kontrolle aus Sicherheitsgründen  
3) Verschlussabstand an Schulter  
\* Grundmaße

<b>C.I.P.</b>	<b>7,62 x 39</b>		<b>TAB.</b>	<b>I</b>
	Ursprungsland: SU		Datum	89-01-04
			Revision	13-05-22
	<b>PATRONE MAXI</b>		<b>PATRONENLAGER MINI</b>	
	<p><b>Längen</b></p> <p>L1 <sup>1)</sup>* = 30.50 -0.20                      L2 <sup>1)</sup>* = 33.00 -0.20                      L3 <sup>1)</sup> = 38.70                      L4 =                      L5 =                      L6 = 56.00</p> <p><b>Hülsenboden</b></p> <p>R = 1.50                      R1 = 11.35                      R3 =                      E = 3.20                      E1 = 9.56                      e min = 1.00                      δ = 51°58'12"                      f = 0.25                      β = 45°</p> <p><b>Pulverkammer</b></p> <p>P1 = 11.35                      P2 <sup>1)</sup>* = 10.07 -0.20</p> <p><b>Schulterkonus</b></p> <p>α = 32°46'                      S = 47.63                      r1 min = 4.00                      r2 = 3.00</p> <p><b>Hülsenhals</b></p> <p>H1 * = 8.60                      H2 <sup>1)</sup> = 8.60</p> <p><b>Geschoss</b></p> <p>G1 <sup>1)</sup> = 7.92                      G2 =                      F =                      L3+G <sup>1)</sup> = 46.70</p> <p><b>Drücke (Energien)</b></p> <p><b>Mech. elektr. Wandler</b></p> <p>Pmax = 3550 bar                      PK = 4083 bar                      PE = 4440 bar                      M = 25.00                      EE = 2510 Joule</p> <p><b>Verschiedene Daten</b></p> <p>Fe <sup>1)3)</sup> = 0.15                      delta L = 0.20</p>		<p><b>Längen</b></p> <p>L1 * = 30.25                      L2 * = 32.55                      L3 <sup>1)</sup> = 41.00</p> <p><b>Stoßboden</b></p> <p>R = 1.50                      R1 = 11.37                      R2 =                      R3 =                      r =</p> <p><b>Pulverkammer</b></p> <p>E = 3.50                      P1 <sup>1)</sup> = 11.36                      P2 * = 10.12</p> <p><b>Schulterkonus</b></p> <p>α <sup>1)</sup> = 33°23'54"                      S = 47.12                      r1 max = 0.50                      r2 = 3.00</p> <p><b>Hülsenhals</b></p> <p>H1 * = 8.74                      H2 <sup>1)</sup> = 8.60</p> <p><b>Geschossübergang</b></p> <p>G1 <sup>1)</sup>* = 8.60                      G <sup>1)</sup>* = 8.00                      α1 =                      h =                      s =                      i <sup>1)</sup> = 3°30'18"                      w =</p> <p><b>Lauf</b></p> <p>F <sup>1)</sup>* = 7.62                      Z <sup>1)</sup> = 7.92</p> <p><b>Züge</b></p> <p>b = 3.81                      N = 4                      u = 240.00                      Q = 47.99 mm<sup>2</sup></p>	
Maßstab 1.19:1				
Maße in << mm >> Maße und Toleranzen für Messläufe siehe Anhang CR 1.		Bemerkungen: 1) Kontrolle aus Sicherheitsgründen 3) Verschlussabstand an Schulter * Grundmaße		

<b>C.I.P.</b>	<b>7,62 x 45</b>		<b>TAB.</b>	<b>I</b>
	Ursprungsland: CS		Datum	92-08-03
			Revision	08-09-23
	<b>PATRONE MAXI</b>		<b>PATRONENLAGER MINI</b>	
	<p><b>Längen</b></p> <p>L1 <sup>1)</sup>* = 36.20 -0.20</p> <p>L2 <sup>1)</sup>* = 38.25 -0.20</p> <p>L3 <sup>1)</sup> = 45.00</p> <p>L4 =</p> <p>L5 =</p> <p>L6 = 60.00</p> <p><b>Hülsenboden</b></p> <p>R = 1.50</p> <p>R1 = 11.30</p> <p>R3 =</p> <p>E = 3.99</p> <p>E1 = 9.70</p> <p>e min = 1.10</p> <p>delta = 30°</p> <p>f = 0.50</p> <p>beta = 45°</p> <p><b>Pulverkammer</b></p> <p>P1 = 11.30</p> <p>P2 <sup>1)</sup>* = 10.56 -0.20</p> <p><b>Schulterkonus</b></p> <p>alpha = 49°43'39"</p> <p>S = 47.59</p> <p>r1 min = 0.50</p> <p>r2 = 0.50</p> <p><b>Hülsenhals</b></p> <p>H1 * = 8.66</p> <p>H2 <sup>1)</sup> = 8.66</p> <p><b>Geschoss</b></p> <p>G1 <sup>1)</sup> = 7.83</p> <p>G2 =</p> <p>F =</p> <p>L3+G <sup>1)</sup> = 65.93</p> <p><b>Drücke (Energien)</b></p> <p><b>Mech. elektr. Wandler</b></p> <p>Pmax = 4300 bar</p> <p>PK = 4945 bar</p> <p>PE = 5375 bar</p> <p>M = 25.00</p> <p>EE = 2515 Joule</p> <p><b>Verschiedene Daten</b></p> <p>Fe <sup>1)3)</sup> = 0.10</p> <p>delta L =</p>		<p><b>Längen</b></p> <p>L1 * = 36.20</p> <p>L2 * = 38.12</p> <p>L3 <sup>1)</sup> = 45.40</p> <p><b>Stoßboden</b></p> <p>R =</p> <p>R1 = 11.45</p> <p>R2 =</p> <p>R3 =</p> <p>r =</p> <p><b>Pulverkammer</b></p> <p>E = 3.99</p> <p>P1 <sup>1)</sup> = 11.35</p> <p>P2 * = 10.56</p> <p><b>Schulterkonus</b></p> <p>alpha <sup>1)</sup> = 50°13'46"</p> <p>S = 47.46</p> <p>r1 max = 0.50</p> <p>r2 = 1.00</p> <p><b>Hülsenhals</b></p> <p>H1 * = 8.76</p> <p>H2 <sup>1)</sup> = 8.70</p> <p><b>Geschossübergang</b></p> <p>G1 <sup>1)</sup>* = 7.90</p> <p>G <sup>1)</sup>* = 20.93</p> <p>alpha l = 180°</p> <p>h =</p> <p>s =</p> <p>i <sup>1)</sup> = 0°22'59"</p> <p>w =</p> <p><b>Lauf</b></p> <p>F <sup>1)</sup>* = 7.62</p> <p>Z <sup>1)</sup> = 7.88</p> <p><b>Züge</b></p> <p>b = 3.50</p> <p>N = 4</p> <p>u = 280.00</p> <p>Q = 47.49 mm<sup>2</sup></p>	
<p>Maßstab 1.06:1</p> <p>Maße in &lt;&lt; mm &gt;&gt;</p> <p>Maße und Toleranzen für Messläufe siehe Anhang CR 1.</p>			<p>Bemerkungen: 1) Kontrolle aus Sicherheitsgründen 3) Verschlussabstand an Schulter * Grundmaße</p>	

<b>C.I.P.</b>	<b>7,62 UKM</b>		<b>TAB.</b>	<b>I</b>
	Ursprungsland: DE		Datum	02-01-22
			Revision	08-09-23
	<b>PATRONE MAXI</b>		<b>PATRONENLAGER MINI</b>	
	<p><b>Längen</b></p> <p>L1 <sup>1)</sup>* = 41.57 -0.20</p> <p>L2 <sup>1)</sup>* = 48.96 -0.20</p> <p>L3 <sup>1)</sup> = 57.00</p> <p>L4 =</p> <p>L5 =</p> <p>L6 = 79.00</p> <p><b>Hülsenboden</b></p> <p>R = 1.52</p> <p>R1 = 14.93</p> <p>R3 =</p> <p>E = 3.12</p> <p>E1 = 13.24</p> <p>e min = 0.90</p> <p>δ = 50°01'33"</p> <p>f = 0.50</p> <p>β = 45°</p> <p><b>Pulverkammer</b></p> <p>P1 = 14.91</p> <p>P2 <sup>1)</sup>* = 14.08 -0.20</p> <p><b>Schulterkonus</b></p> <p>α = 40°08'26"</p> <p>S = 60.84</p> <p>r1 min =</p> <p>r2 = 2.00</p> <p><b>Hülsenhals</b></p> <p>H1 * = 8.68</p> <p>H2 <sup>1)</sup> = 8.68</p> <p><b>Geschoss</b></p> <p>G1 <sup>1)</sup> = 7.85</p> <p>G2 =</p> <p>F =</p> <p>L3+G <sup>1)</sup> = 64.89</p> <p><b>Drücke (Energien)</b></p> <p><b>Mech. elektr. Wandler</b></p> <p>Pmax = 4400 bar</p> <p>PK = 5060 bar</p> <p>PE = 5500 bar</p> <p>M = 25.00</p> <p>EE = 5565 Joule</p> <p><b>Verschiedene Daten</b></p> <p>Fe <sup>1)3)</sup> = 0.10</p> <p>delta L =</p>		<p><b>Längen</b></p> <p>L1 * = 41.50</p> <p>L2 * = 48.93</p> <p>L3 <sup>1)</sup> = 57.20</p> <p><b>Stoßboden</b></p> <p>R =</p> <p>R1 = 15.03</p> <p>R2 =</p> <p>R3 =</p> <p>r =</p> <p><b>Pulverkammer</b></p> <p>E = 3.12</p> <p>P1 <sup>1)</sup> = 14.96</p> <p>P2 * = 14.13</p> <p><b>Schulterkonus</b></p> <p>α <sup>1)</sup> = 40°00'33"</p> <p>S = 60.91</p> <p>r1 max =</p> <p>r2 = 2.50</p> <p><b>Hülsenhals</b></p> <p>H1 * = 8.72</p> <p>H2 <sup>1)</sup> = 8.70</p> <p><b>Geschossübergang</b></p> <p>G1 <sup>1)</sup>* = 7.85</p> <p>G <sup>1)</sup>* = 7.89</p> <p>α1 = 45°</p> <p>h = 1.03</p> <p>s * = 3.50</p> <p>i <sup>1)</sup> = 1°30'02"</p> <p>w =</p> <p><b>Lauf</b></p> <p>F <sup>1)</sup>* = 7.62</p> <p>Z <sup>1)</sup> = 7.82</p> <p><b>Züge</b></p> <p>b = 2.79</p> <p>N = 6</p> <p>u = 254.00</p> <p>Q = 47.32 mm<sup>2</sup></p>	
<p>Maßstab 1:1.04</p> <p>Maße in &lt;&lt; mm &gt;&gt;</p> <p>Maße und Toleranzen für Messläufe siehe Anhang CR 1.</p>			<p>Bemerkungen: 1) Kontrolle aus Sicherheitsgründen 3) Verschlussabstand an Schulter * Grundmaße</p>	

<b>C.I.P.</b>	<b>7,65 x 53 Arg.</b> Ursprungsland: DE	TAB. <b>I</b>
		Datum <b>84-06-14</b>
		Revision <b>02-05-15</b>
	<b>PATRONE MAXI</b>	<b>PATRONENLAGER MINI</b>
	<p><b>Längen</b></p> <p>L1 <sup>1)</sup>* = 44.60 -0.20                  L2 <sup>1)</sup>* = 47.20 -0.20                  L3 <sup>1)</sup> = 53.60                  L4 =                  L5 =                  L6 = 76.00</p> <p><b>Hülsenboden</b></p> <p>R = 1.00                  R1 = 12.05                  R3 =                  E = 3.20                  E1 = 10.40                  e min = 1.10                  delta = 35°41'24"                  f = 0.30                  beta = 45°</p> <p><b>Pulverkammer</b></p> <p>P1 = 12.01                  P2 <sup>1)</sup>* = 10.90 -0.20</p> <p><b>Schulterkonus</b></p> <p>alpha = 44°21'38"                  S = 57.97                  r1 min = 2.20                  r2 = 2.20</p> <p><b>Hülsenhals</b></p> <p>H1 <sup>1)</sup>* = 8.78                  H2 = 8.78</p> <p><b>Geschoss</b></p> <p>G1 <sup>1)</sup> = 7.94                  G2 =                  F =                  L3+G <sup>1)</sup> = 73.60</p> <p><b>Drücke (Energien)</b>  <b>Mech. elektr. Wandler</b></p> <p>Pmax = 3900 bar                  PK = 4485 bar                  PE = 4875 bar                  M = 25.00                  EE = 3700 Joule</p> <p><b>Verschiedene Daten</b></p> <p>Fe <sup>1)</sup> = 0.10                  delta L = 0.18</p>	<p><b>Längen</b></p> <p>L1 * = 44.50                  L2 * = 47.00                  L3 <sup>1)</sup> = 53.70</p> <p><b>Stoßboden</b></p> <p>R = 1.00                  R1 = 12.13                  R2 =                  R3 =                  r =</p> <p><b>Pulverkammer</b></p> <p>E = 3.20                  P1 <sup>1)</sup> = 12.05                  P2 * = 10.93</p> <p><b>Schulterkonus</b></p> <p>alpha <sup>1)</sup> = 46°08'53"                  S = 57.33                  r1 max = 2.20                  r2 = 2.20</p> <p><b>Hülsenhals</b></p> <p>H1 * = 8.80                  H2 <sup>1)</sup> = 8.80</p> <p><b>Geschossübergang</b></p> <p>G1 <sup>1)</sup>* = 8.00                  G <sup>1)</sup>* = 20.00                  alpha1 = 90°                  h * = 0.40                  s =                  i <sup>1)</sup> = 0°30'42"                  w =</p> <p><b>Lauf</b></p> <p>F <sup>1)</sup>* = 7.65                  Z <sup>1)</sup> = 7.92</p> <p><b>Züge</b></p> <p>b = 4.20                  N = 4                  u = 280.00                  Q = 48.36 mm<sup>2</sup></p>
Maßstab 1:1		
Maße in << mm >> Maße und Toleranzen für Messläufe siehe Anhang CR 1.	Bemerkungen: 1) Kontrolle aus Sicherheitsgründen * Grundmaße	

<b>C.I.P.</b>	<b>7,82 Warbird</b>		<b>TAB.</b>	<b>I</b>
	Ursprungsland: FI		<b>Datum</b>	<b>00-02-15</b>
			<b>Revision</b>	<b>08-09-23</b>
	<b>PATRONE MAXI</b>		<b>PATRONENLAGER MINI</b>	
	<p><b>Längen</b></p> <p>L1 <sup>1)</sup>* = 58.70 -0.20</p> <p>L2 <sup>1)</sup>* = 63.40 -0.20</p> <p>L3 <sup>1)</sup> = 71.37</p> <p>L4 =</p> <p>L5 =</p> <p>L6 = 92.20</p> <p><b>Hülsenboden</b></p> <p>R = 1.65</p> <p>R1 = 14.76</p> <p>R3 =</p> <p>E = 3.94</p> <p>E1 = 12.95</p> <p>e min = 1.40</p> <p>delta = 45°</p> <p>f = 0.64</p> <p>beta = 45°</p> <p><b>Pulverkammer</b></p> <p>P1 = 14.73</p> <p>P2 <sup>1)</sup>* = 14.22 -0.20</p> <p><b>Schulterkonus</b></p> <p>alpha = 60°01'36"</p> <p>S = 71.01</p> <p>r1 min = 1.57</p> <p>r2 = 1.57</p> <p><b>Hülsenhals</b></p> <p>H1 * = 8.79</p> <p>H2 <sup>1)</sup> = 8.76</p> <p><b>Geschoss</b></p> <p>G1 <sup>1)</sup> = 7.84</p> <p>G2 =</p> <p>F =</p> <p>L3+G <sup>1)</sup> = 76.33</p> <p><b>Drücke (Energien)</b></p> <p><b>Mech. elektr. Wandler</b></p> <p>Pmax = 4400 bar</p> <p>PK = 5060 bar</p> <p>PE = 5500 bar</p> <p>M = 25.00</p> <p>EE = 6760 Joule</p> <p><b>Verschiedene Daten</b></p> <p>Fe <sup>1)3)</sup> = 0.10</p> <p>delta L = 0.05</p>		<p><b>Längen</b></p> <p>L1 * = 58.58</p> <p>L2 * = 63.31</p> <p>L3 <sup>1)</sup> = 71.63</p> <p><b>Stoßboden</b></p> <p>R =</p> <p>R1 = 14.81</p> <p>R2 =</p> <p>R3 =</p> <p>r =</p> <p><b>Pulverkammer</b></p> <p>E = 3.94</p> <p>P1 <sup>1)</sup> = 14.78</p> <p>P2 * = 14.30</p> <p><b>Schulterkonus</b></p> <p>alpha <sup>1)</sup> = 59°59'03"</p> <p>S = 70.97</p> <p>r1 max = 1.57</p> <p>r2 = 1.57</p> <p><b>Hülsenhals</b></p> <p>H1 * = 8.84</p> <p>H2 <sup>1)</sup> = 8.81</p> <p><b>Geschossübergang</b></p> <p>G1 <sup>1)</sup>* = 7.85</p> <p>G <sup>1)</sup>* = 4.96</p> <p>alpha1 = 90°</p> <p>h = 0.48</p> <p>s * = 2.33</p> <p>i <sup>1)</sup> = 2°30'12"</p> <p>w =</p> <p><b>Lauf</b></p> <p>F <sup>1)</sup>* = 7.62</p> <p>Z <sup>1)</sup> = 7.82</p> <p><b>Züge</b></p> <p>b = 2.91</p> <p>N = 6</p> <p>u = 305.00</p> <p>Q = 47.38 mm<sup>2</sup></p>	
<p>Maßstab 1:1.15</p> <p>Maße in &lt;&lt; mm &gt;&gt;</p> <p>Maße und Toleranzen für Messläufe siehe Anhang CR 1.</p>		<p>Bemerkungen: 1) Kontrolle aus Sicherheitsgründen 3) Verschlussabstand an Schulter * Grundmaße</p>		



<b>C.I.P.</b>	<b>7,92 x 24 VBR</b>	TAB.	I
		Datum	07-05-14
		Revision	
Ursprungsland: BE			
	<b>PATRONE MAXI</b>	<b>PATRONENLAGER MINI</b>	
	<b>Längen</b> L1 = -0.20 L2 = -0.20 L3 <sup>1)</sup> = 24.00 L4 = 25.24 L5 = L6 = 32.10  <b>Hülsenboden</b> R = 1.27 R1 = 9.14 R3 = E = 2.90 E1 = 7.87 e min = 0.84 delta = 37° f = 0.38 beta = 35°  <b>Pulverkammer</b> P1 = 9.06 P2 = -0.20  <b>Schulterkonus</b> alpha = S = r1 min = r2 =  <b>Hülsenhals</b> H1 = H2 <sup>1)</sup> = 8.62  <b>Geschoss</b> G1 <sup>1)</sup> = 7.92 G2 = 7.92 F = L3+G <sup>1)</sup> = 29.09  <b>Drücke (Energien)</b> <b>Mech. elektr. Wandler</b> Pmax = 3310 bar PK = 3807 bar PE = 4300 bar M = 17.50 EE = 660 Joule  <b>Verschiedene Daten</b> Fe <sup>1)6)</sup> = 0.15 delta L =	<b>Längen</b> L1 = L2 = L3 <sup>1)</sup> = 24.00  <b>Stoßboden</b> R = 1.27 R1 = 9.40 R2 = R3 = r =  <b>Pulverkammer</b> E = 2.90 P1 <sup>1)</sup> = 9.15 P2 =  <b>Schulterkonus</b> alpha = S = r1 max = r2 =  <b>Hülsenhals</b> H1 = H2 <sup>1)</sup> = 8.69  <b>Geschossübergang</b> G1 <sup>1)</sup> * = 8.03 G <sup>1)</sup> * = 3.91 alpha <sup>1)</sup> * = 180° h = s = i <sup>1)</sup> * = 3°00'04" w =  <b>Lauf</b> F <sup>1)</sup> * = 7.62 Z <sup>1)</sup> = 7.82  <b>Züge</b> b = 2.92 N = 6 u = 250.00 Q = 47.40 mm <sup>2</sup>	
Maßstab 1.5:1  Maße in << mm >> Maße und Toleranzen für Messläufe siehe Anhang CR 1.		Bemerkungen: 1) Kontrolle aus Sicherheitsgründen 6) Verschlussabstand an Hülsenmund * Grundmaße	

<b>C.I.P.</b>	<b>7,92 x 33 kurz</b>		<b>TAB.</b>	<b>I</b>
	Ursprungsland: DE		Datum	84-06-14
			Revision	14-05-20
	<b>PATRONE MAXI</b>		<b>PATRONENLAGER MINI</b>	
	<p><b>Längen</b></p> <p>L1 * = 24.38 -0.20                      L2 * = 28.03 -0.20                      L3 <sup>1)</sup> = 33.00                      L4 =                      L5 =                      L6 = 48.00</p> <p><b>Hülsenboden</b></p> <p>R = 1.30                      R1 = 11.95                      R3 =                      E = 3.50                      E1 = 10.50                      e min = 1.00                      delta = 31°                      f = 0.30                      beta = 45°</p> <p><b>Pulverkammer</b></p> <p>P1 = 11.94                      P2 <sup>1)</sup>* = 11.40 -0.20</p> <p><b>Schulterkonus</b></p> <p>alpha = 34°58'34"                      S = 42.47                      r1 min = 0.50                      r2 = 0.50</p> <p><b>Hülsenhals</b></p> <p>H1 * = 9.10                      H2 <sup>1)</sup> = 9.04</p> <p><b>Geschoss</b></p> <p>G1 <sup>1)</sup> = 8.22                      G2 =                      F =                      L3+G <sup>1)</sup> = 39.53</p> <p><b>Drücke (Energien)</b></p> <p><b>Mech. elektr. Wandler</b></p> <p>Pmax = 3400 bar                      PK = 3910 bar                      PE = 4250 bar                      M = 17.50                      EE = 1770 Joule</p> <p><b>Verschiedene Daten</b></p> <p>Fe <sup>1)3)</sup> = 0.15                      delta L =</p>		<p><b>Längen</b></p> <p>L1 * = 24.35                      L2 * = 27.98                      L3 <sup>1)</sup> = 33.30</p> <p><b>Stoßboden</b></p> <p>R = 1.30                      R1 = 12.00                      R2 =                      R3 =                      r =</p> <p><b>Pulverkammer</b></p> <p>E = 3.50                      P1 <sup>1)</sup> = 11.97                      P2 * = 11.42</p> <p><b>Schulterkonus</b></p> <p>alpha <sup>1)</sup> = 35°00'48"                      S = 42.45                      r1 max = 0.50                      r2 = 0.50</p> <p><b>Hülsenhals</b></p> <p>H1 * = 9.13                      H2 <sup>1)</sup> = 9.05</p> <p><b>Geschossübergang</b></p> <p>G1 <sup>1)</sup>* = 8.24                      G <sup>1)</sup>* = 6.53                      alpha l = 180°                      h =                      s =                      i <sup>1)</sup> = 1°32'7"                      w =</p> <p><b>Lauf</b></p> <p>F <sup>1)</sup>* = 7.89                      Z <sup>1)</sup> = 8.20</p> <p><b>Züge</b></p> <p>b = 4.40                      N = 4                      u = 240.00                      Q = 51.78 mm<sup>2</sup></p>	
<p>Maßstab 1.14:1</p> <p style="text-align: center;">Maße in &lt;&lt; mm &gt;&gt; Maße und Toleranzen für Messläufe siehe Anhang .</p>		<p>Bemerkungen: 1) Kontrolle aus Sicherheitsgründen                      3) Verschlussabstand an Schulter                      * Grundmaße</p>		

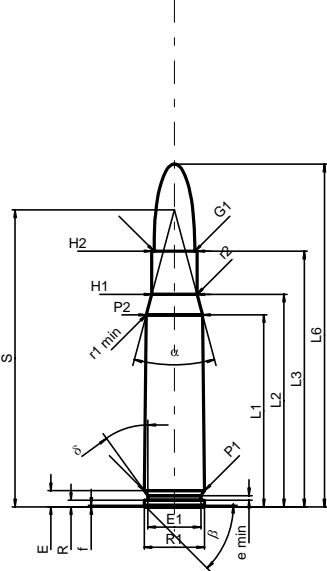
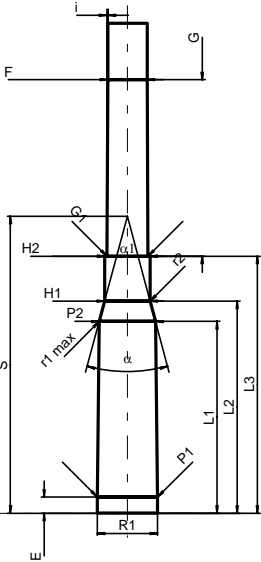
<b>C.I.P.</b>	<b>8 x 51 (Mauser K)</b>  Ursprungsland: DE	TAB. <b>I</b>
		Datum <b>84-06-14</b>
		Revision <b>02-05-15</b>
	<b>PATRONE MAXI</b>	<b>PATRONENLAGER MINI</b>
	<p><b>Längen</b></p> <p>L1 <sup>1)</sup>* = 38.09 -0.20                  L2 <sup>1)</sup>* = 42.16 -0.20                  L3 <sup>1)</sup> = 50.70                  L4 =                  L5 =                  L6 = 68.00</p> <p><b>Hülsenboden</b></p> <p>R = 1.30                  R1 = 11.95                  R3 =                  E = 3.20                  E1 = 10.50                  e min = 0.90                  delta = 36°                  f = 0.30                  beta = 45°</p> <p><b>Pulverkammer</b></p> <p>P1 = 11.95                  P2 <sup>1)</sup>* = 11.15 -0.20</p> <p><b>Schulterkonus</b></p> <p>alpha = 29°59'08"                  S = 58.91                  r1 min = 0.50                  r2 = 0.50</p> <p><b>Hülsenhals</b></p> <p>H1 * = 8.97                  H2 <sup>1)</sup> = 8.97</p> <p><b>Geschoss</b></p> <p>G1 <sup>1)</sup> = 8.07                  G2 =                  F =                  L3+G <sup>1)</sup> = 85.70</p> <p><b>Drücke (Energien)</b>  <b>Mech. elektr. Wandler</b></p> <p>Pmax = 3400 bar                  PK = 3910 bar                  PE = 4250 bar                  M = 25.00                  EE = 2635 Joule</p> <p><b>Verschiedene Daten</b></p> <p>Fe <sup>1)</sup> = 0.15                  delta L =</p>	<p><b>Längen</b></p> <p>L1 * = 38.04                  L2 * = 42.09                  L3 <sup>1)</sup> = 51.00</p> <p><b>Stoßboden</b></p> <p>R = 1.30                  R1 = 12.00                  R2 =                  R3 =                  r =</p> <p><b>Pulverkammer</b></p> <p>E = 3.20                  P1 <sup>1)</sup> = 11.98                  P2 * = 11.18</p> <p><b>Schulterkonus</b></p> <p>alpha <sup>1)</sup> = 29°59'42"                  S = 58.91                  r1 max = 0.50                  r2 = 0.50</p> <p><b>Hülsenhals</b></p> <p>H1 * = 9.01                  H2 <sup>1)</sup> = 9.00</p> <p><b>Geschossübergang</b></p> <p>G1 <sup>1)</sup>* = 8.15                  G <sup>1)</sup>* = 35.00                  alpha1 = 180°                  h =                  s =                  i <sup>1)</sup> = 0°17'11"                  w =</p> <p><b>Lauf</b></p> <p>F <sup>1)</sup>* = 7.80                  Z <sup>1)</sup> = 8.07</p> <p><b>Züge</b></p> <p>b = 4.40                  N = 4                  u = 240.00                  Q = 50.30 mm<sup>2</sup></p>
		
Maßstab 1:1.5		
Maße in << mm >> Maße und Toleranzen für Messläufe siehe Anhang CR 1.	Bemerkungen: 1) Kontrolle aus Sicherheitsgründen * Grundmaße	

<b>C.I.P.</b>	<b>8 x 56 M.-Sch.</b> Ursprungsland: AT	TAB. <b>I</b>
		Datum <b>84-06-14</b>
		Revision <b>02-05-15</b>
	<b>PATRONE MAXI</b>	<b>PATRONENLAGER MINI</b>
	<p><b>Längen</b></p> <p>L1 <sup>1)</sup>* = 46.00 -0.20                  L2 <sup>1)</sup>* = 48.30 -0.20                  L3 <sup>1)</sup> = 56.40                  L4 =                  L5 = 56.70                  L6 = 77.80</p> <p><b>Hülsenboden</b></p> <p>R = 1.20                  R1 = 11.85                  R3 =                  E = 3.30                  E1 = 10.30                  e min = 1.00                  delta = 33°45'                  f =                  beta = 90°</p> <p><b>Pulverkammer</b></p> <p>P1 = 11.77                  P2 <sup>1)</sup>* = 10.80 +0.20</p> <p><b>Schulterkonus</b></p> <p>alpha = 43°49'02"                  S = 59.43                  r1 min = 0.50                  r2 = 0.50</p> <p><b>Hülsenhals</b></p> <p>H1* = 8.95                  H2 <sup>1)</sup> = 8.90</p> <p><b>Geschoss</b></p> <p>G1 <sup>1)</sup> = 8.25                  G2 = 8.25                  F =                  L3+G <sup>1)</sup> = 77.50</p> <p><b>Drücke (Energien)</b></p> <p><b>Mech. elektr. Wandler</b></p> <p>Pmax = 3200 bar                  PK = 3680 bar                  PE = 4000 bar                  M = 25.00                  EE = 2860 Joule</p> <p><b>Verschiedene Daten</b></p> <p>Fe <sup>1)</sup> = 0.15                  delta L =</p>	<p><b>Längen</b></p> <p>L1* = 46.00                  L2* = 48.30                  L3 <sup>1)</sup> = 56.40</p> <p><b>Stoßboden</b></p> <p>R = 1.20                  R1 = 11.90                  R2 =                  R3 =                  r =</p> <p><b>Pulverkammer</b></p> <p>E = 3.30                  P1 <sup>1)</sup> = 11.83                  P2* = 10.85</p> <p><b>Schulterkonus</b></p> <p>alpha <sup>1)</sup> = 43°49'02"                  S = 59.49                  r1 max = 0.50                  r2 = 0.50</p> <p><b>Hülsenhals</b></p> <p>H1* = 9.00                  H2 <sup>1)</sup> = 8.95</p> <p><b>Geschossübergang</b></p> <p>G1 <sup>1)</sup>* = 8.40                  G <sup>1)</sup>* = 21.10                  alpha1 = 180°                  h =                  s =                  i <sup>1)</sup> = 0°36'39"                  w =</p> <p><b>Lauf</b></p> <p>F <sup>1)</sup>* = 7.95                  Z <sup>1)</sup> = 8.30</p> <p><b>Züge</b></p> <p>b = 3.80                  N = 4                  u = 250.00                  Q = 52.41 mm<sup>2</sup></p>
Maßstab 1:1		
Maße in << mm >> Maße und Toleranzen für Messläufe siehe Anhang CR 1.	Bemerkungen: 1) Kontrolle aus Sicherheitsgründen * Grundmaße	

<b>C.I.P.</b>	<b>8 x 57 I</b>		<b>TAB.</b>	<b>I</b>
	Ursprungsland: DE		<b>Datum</b>	<b>84-06-14</b>
			<b>Revision</b>	<b>02-05-15</b>
	<b>PATRONE MAXI</b>		<b>PATRONENLAGER MINI</b>	
	<p><b>Längen</b></p> <p>L1 <sup>1)</sup>* = 46.20 -0.20</p> <p>L2 <sup>1)</sup>* = 49.03 -0.20</p> <p>L3 <sup>1)</sup> = 57.00</p> <p>L4 =</p> <p>L5 =</p> <p>L6 = 82.00</p> <p><b>Hülsenboden</b></p> <p>R = 1.30</p> <p>R1 = 11.95</p> <p>R3 =</p> <p>E = 3.20</p> <p>E1 = 10.50</p> <p>e min = 1.00</p> <p>δ = 38°39'36"</p> <p>f = 0.30</p> <p>β = 45°</p> <p><b>Pulverkammer</b></p> <p>P1 = 11.94</p> <p>P2 <sup>1)</sup>* = 10.95 -0.20</p> <p><b>Schulterkonus</b></p> <p>α = 38°12'02"</p> <p>S = 62.01</p> <p>r1 min = 0.50</p> <p>r2 = 0.50</p> <p><b>Hülsenhals</b></p> <p>H1 * = 8.99</p> <p>H2 <sup>1)</sup> = 8.99</p> <p><b>Geschoss</b></p> <p>G1 <sup>1)</sup> = 8.09</p> <p>G2 =</p> <p>F =</p> <p>L3+G <sup>1)</sup> = 99.00</p> <p><b>Drücke (Energien)</b></p> <p><b>Mech. elektr. Wandler</b></p> <p>Pmax = 3800 bar</p> <p>PK = 4370 bar</p> <p>PE = 4750 bar</p> <p>M = 25.00</p> <p>EE = 3950 Joule</p> <p><b>Verschiedene Daten</b></p> <p>Fe <sup>1)</sup> = 0.15</p> <p>delta L =</p>		<p><b>Längen</b></p> <p>L1 * = 46.16</p> <p>L2 * = 48.98</p> <p>L3 <sup>1)</sup> = 57.30</p> <p><b>Stoßboden</b></p> <p>R = 1.30</p> <p>R1 = 12.00</p> <p>R2 =</p> <p>R3 =</p> <p>r =</p> <p><b>Pulverkammer</b></p> <p>E = 3.20</p> <p>P1 <sup>1)</sup> = 11.97</p> <p>P2 * = 10.98</p> <p><b>Schulterkonus</b></p> <p>α <sup>1)</sup> = 38°19'34"</p> <p>S = 61.96</p> <p>r1 max = 0.50</p> <p>r2 = 0.50</p> <p><b>Hülsenhals</b></p> <p>H1 * = 9.02</p> <p>H2 <sup>1)</sup> = 9.01</p> <p><b>Geschossübergang</b></p> <p>G1 <sup>1)</sup>* = 8.15</p> <p>G <sup>1)</sup>* = 42.00</p> <p>α1 = 90°</p> <p>h * = 0.43</p> <p>s =</p> <p>i <sup>1)</sup> = 0°14'28"</p> <p>w =</p> <p><b>Lauf</b></p> <p>F <sup>1)</sup>* = 7.80</p> <p>Z <sup>1)</sup> = 8.07</p> <p><b>Züge</b></p> <p>b = 4.40</p> <p>N = 4</p> <p>u = 240.00</p> <p>Q = 50.30 mm<sup>2</sup></p>	
<p>Maßstab 1:1.5</p> <p>Maße in &lt;&lt; mm &gt;&gt;</p> <p>Maße und Toleranzen für Messläufe siehe Anhang CR 1.</p>		<p>Bemerkungen: 1) Kontrolle aus Sicherheitsgründen * Grundmaße</p>		

<b>C.I.P.</b>	<b>8 x 57 IS</b> Ursprungsland: DE	TAB.	I	
		Datum	84-06-14	
		Revision	16-05-18	
Alternative Namen: 8 x 57 JS				
	<b>PATRONE MAXI</b>		<b>PATRONENLAGER MINI</b>	
	<b>Längen</b> L1 <sup>1)</sup> * = 46.20 -0.20 L2 <sup>1)</sup> * = 48.90 -0.20 L3 <sup>1)</sup> = 57.00 L4 = L5 = L6 = 82.00  <b>Hülsenboden</b> R = 1.30 R1 = 11.95 R3 = E = 3.19 E1 = 10.50 e min = 0.90 delta = 36° f = 0.30 beta = 45°  <b>Pulverkammer</b> P1 = 11.94 P2 <sup>1)</sup> * = 10.95 -0.20  <b>Schulterkonus</b> alpha = 38°12'06" S = 62.01 r1 min = 0.50 r2 = 0.50  <b>Hülsenhals</b> H1 * = 9.08 H2 <sup>1)</sup> = 9.08  <b>Geschoss</b> G1 <sup>1)</sup> = 8.22 G2 = F = L3+G <sup>1)</sup> = 92.00  <b>Drücke (Energien)</b> <b>Mech. elektr. Wandler</b> Pmax = 3900 bar PK = 4485 bar PE = 4875 bar M = 25.00 EE = 4300 Joule  <b>Verschiedene Daten</b> Fe <sup>1)3)</sup> = 0.10 delta L =		<b>Längen</b> L1 * = 46.16 L2 * = 48.85 L3 <sup>1)</sup> = 57.30  <b>Stoßboden</b> R = 1.30 R1 = 12.00 R2 = R3 = r =  <b>Pulverkammer</b> E = 3.19 P1 <sup>1)</sup> = 11.97 P2 * = 10.98  <b>Schulterkonus</b> alpha <sup>1)</sup> = 38°20' S = 61.95 r1 max = 0.50 r2 = 0.50  <b>Hülsenhals</b> H1 * = 9.11 H2 <sup>1)</sup> = 9.10  <b>Geschossübergang</b> G1 <sup>1)</sup> * = 8.24 G <sup>1)</sup> * = 35.00 alpha l = 180° h * = s = i <sup>1)</sup> = 0°17'11" w =  <b>Lauf</b> F <sup>1)</sup> * = 7.89 Z <sup>1)</sup> = 8.20  <b>Züge</b> b = 4.40 N = 4 u = 240.00 Q = 51.78 mm <sup>2</sup>	
	Maßstab 1:1.22  Maße in << mm >> Maße und Toleranzen für Messläufe siehe Anhang CR 1.			
Bemerkungen: 1) Kontrolle aus Sicherheitsgründen 3) Verschlussabstand an Schulter * Grundmaße				

<b>C.I.P.</b>	<b>8 x 57 PCC</b>	TAB.	I
		Datum	09-05-05
		Revision	
Ursprungsland: IT			
	<b>PATRONE MAXI</b>	<b>PATRONENLAGER MINI</b>	
	<p><b>Längen</b></p> <p>L1 <sup>1)</sup> = 45.82 -0.20                  L2 <sup>1)</sup> = 48.49 -0.20                  L3 <sup>1)</sup> = 57.00                  L4 =                  L5 =                  L6 = 82.00</p> <p><b>Hülsenboden</b></p> <p>R = 1.40                  R1 = 13.60                  R3 =                  E = 3.74                  E1 = 11.70                  e min = 1.20                  delta = 45°                  f =                  beta =</p> <p><b>Pulverkammer</b></p> <p>P1 = 13.97                  P2 <sup>1)</sup>* = 13.53 -0.20</p> <p><b>Schulterkonus</b></p> <p>alpha * = 79°51'50"                  S * = 53.90                  r1 min = 1.30                  r2 = 1.52</p> <p><b>Hülsenhals</b></p> <p>H1 * = 9.06                  H2 <sup>1)</sup> = 9.05</p> <p><b>Geschoss</b></p> <p>G1 <sup>1)</sup> = 8.20                  G2 =                  F =                  L3+G <sup>1)</sup> = 90.54</p> <p><b>Drücke (Energien)</b></p> <p><b>Mech. elektr. Wandler</b></p> <p>Pmax = 4400 bar                  PK = 5060 bar                  PE = 5500 bar                  M = 25.00                  EE = 5200 Joule</p> <p><b>Verschiedene Daten</b></p> <p>Fe <sup>1)3)</sup> = 0.10                  delta L =</p>	<p><b>Längen</b></p> <p>L1 = 46.17                  L2 = 48.84                  L3 <sup>1)</sup> = 57.51</p> <p><b>Stoßboden</b></p> <p>R = 1.40                  R1 = 14.00                  R2 =                  R3 =                  r =</p> <p><b>Pulverkammer</b></p> <p>E = 3.71                  P1 <sup>1)</sup> = 14.00                  P2 * = 13.60</p> <p><b>Schulterkonus</b></p> <p>alpha <sup>1)</sup>* = 80°06'57"                  S * = 54.26                  r1 max = 1.30                  r2 = 1.52</p> <p><b>Hülsenhals</b></p> <p>H1 * = 9.11                  H2 <sup>1)</sup> = 9.10</p> <p><b>Geschossübergang</b></p> <p>G1 <sup>1)</sup>* = 8.24                  G <sup>1)</sup> = 33.54                  alpha l = 90°                  h * = 0.43                  s =                  i <sup>1)</sup>* = 0°18'10"                  w =</p> <p><b>Lauf</b></p> <p>F <sup>1)</sup>* = 7.89                  Z <sup>1)</sup> = 8.20</p> <p><b>Züge</b></p> <p>b = 4.40                  N = 4                  u = 240.00                  Q = 51.78 mm<sup>2</sup></p>	
<p>Maßstab 1:1.5</p> <p>Maße in &lt;&lt; mm &gt;&gt; Maße und Toleranzen für Messläufe siehe Anhang CR 1.</p>		<p>Bemerkungen: 1) Kontrolle aus Sicherheitsgründen 3) Verschlussabstand an Schulter * Grundmaße</p>	

<b>C.I.P.</b>	<b>8 x 60</b>		<b>TAB.</b>	<b>I</b>
	Ursprungsland: DE		Datum	84-06-13
			Revision	11-05-25
	<b>PATRONE MAXI</b>		<b>PATRONENLAGER MINI</b>	
	<p><b>Längen</b></p> <p>L1 <sup>1)</sup>* = 48.20 -0.20</p> <p>L2 <sup>1)</sup>* = 51.04 -0.20</p> <p>L3 <sup>1)</sup> = 60.00</p> <p>L4 =</p> <p>L5 =</p> <p>L6 = 82.00</p> <p><b>Hülsenboden</b></p> <p>R = 1.30</p> <p>R1 = 11.95</p> <p>R3 =</p> <p>E = 3.20</p> <p>E1 = 10.50</p> <p>e min = 1.00</p> <p>δ = 39°25'12"</p> <p>f = 0.30</p> <p>β = 45°</p> <p><b>Pulverkammer</b></p> <p>P1 = 11.98</p> <p>P2 <sup>1)</sup>* = 10.95 -0.20</p> <p><b>Schulterkonus</b></p> <p>α = 38°15'22"</p> <p>S = 63.99</p> <p>r1 min = 0.50</p> <p>r2 = 0.50</p> <p><b>Hülsenhals</b></p> <p>H1 * = 8.98</p> <p>H2 <sup>1)</sup> = 8.98</p> <p><b>Geschoss</b></p> <p>G1 <sup>1)</sup> = 8.09</p> <p>G2 =</p> <p>F =</p> <p>L3+G <sup>1)</sup> = 99.00</p> <p><b>Drücke (Energien)</b></p> <p><b>Mech. elektr. Wandler</b></p> <p>Pmax = 4050 bar</p> <p>PK = 4658 bar</p> <p>PE = 5060 bar</p> <p>M = 25.00</p> <p>EE = 3900 Joule</p> <p><b>Verschiedene Daten</b></p> <p>Fe <sup>1)3)</sup> = 0.10</p> <p>delta L =</p>		<p><b>Längen</b></p> <p>L1 * = 48.16</p> <p>L2 * = 51.00</p> <p>L3 <sup>1)</sup> = 60.30</p> <p><b>Stoßboden</b></p> <p>R = 1.30</p> <p>R1 = 12.00</p> <p>R2 =</p> <p>R3 =</p> <p>r =</p> <p><b>Pulverkammer</b></p> <p>E = 3.20</p> <p>P1 <sup>1)</sup> = 12.01</p> <p>P2 * = 10.98</p> <p><b>Schulterkonus</b></p> <p>α <sup>1)</sup> = 38°15'22"</p> <p>S = 63.99</p> <p>r1 max = 0.50</p> <p>r2 = 0.50</p> <p><b>Hülsenhals</b></p> <p>H1 * = 9.01</p> <p>H2 <sup>1)</sup> = 9.00</p> <p><b>Geschossübergang</b></p> <p>G1 <sup>1)</sup>* = 8.12</p> <p>G <sup>1)</sup>* = 39.00</p> <p>α1 = 90°</p> <p>h * = 0.44</p> <p>s =</p> <p>i <sup>1)</sup> = 0°14'16"</p> <p>w =</p> <p><b>Lauf</b></p> <p>F <sup>1)</sup>* = 7.80</p> <p>Z <sup>1)</sup> = 8.07</p> <p><b>Züge</b></p> <p>b = 4.40</p> <p>N = 4</p> <p>u = 240.00</p> <p>Q = 50.30 mm<sup>2</sup></p>	
<p>Maßstab 1:1.26</p> <p>Maße in &lt;&lt; mm &gt;&gt;</p> <p>Maße und Toleranzen für Messläufe siehe Anhang CR 1.</p>		<p>Bemerkungen: 1) Kontrolle aus Sicherheitsgründen 3) Verschlussabstand an Schulter * Grundmaße</p>		



<b>C.I.P.</b>	<b>8 x 60 S</b>		<b>TAB.</b>	<b>I</b>
	Ursprungsland: DE		<b>Datum</b>	<b>84-06-14</b>
			<b>Revision</b>	<b>06-09-19</b>
	<b>PATRONE MAXI</b>		<b>PATRONENLAGER MINI</b>	
	<p><b>Längen</b></p> <p>L1 <sup>1)</sup>* = 48.20 -0.20</p> <p>L2 <sup>1)</sup>* = 50.90 -0.20</p> <p>L3 <sup>1)</sup> = 60.00</p> <p>L4 = 63.20</p> <p>L5 =</p> <p>L6 = 83.60</p> <p><b>Hülsenboden</b></p> <p>R = 1.30</p> <p>R1 = 11.95</p> <p>R3 =</p> <p>E = 3.20</p> <p>E1 = 10.50</p> <p>e min = 1.00</p> <p>δ = 39°25'48"</p> <p>f = 0.30</p> <p>β = 45°</p> <p><b>Pulverkammer</b></p> <p>P1 = 11.98</p> <p>P2 <sup>1)</sup>* = 10.95 -0.20</p> <p><b>Schulterkonus</b></p> <p>α = 38°12'06"</p> <p>S = 64.01</p> <p>r1 min = 0.50</p> <p>r2 = 0.50</p> <p><b>Hülsenhals</b></p> <p>H1 <sup>*</sup> = 9.08</p> <p>H2 <sup>1)</sup> = 9.08</p> <p><b>Geschoss</b></p> <p>G1 <sup>1)</sup> = 8.22</p> <p>G2 = 8.18</p> <p>F =</p> <p>L3+G <sup>1)</sup> = 94.00</p> <p><b>Drücke (Energien)</b></p> <p><b>Mech. elektr. Wandler</b></p> <p>Pmax = 4050 bar</p> <p>PK = 4658 bar</p> <p>PE = 5060 bar</p> <p>M = 25.00</p> <p>EE = 4285 Joule</p> <p><b>Verschiedene Daten</b></p> <p>Fe <sup>1)</sup> = 0.10</p> <p>delta L =</p>		<p><b>Längen</b></p> <p>L1 <sup>*</sup> = 48.16</p> <p>L2 <sup>*</sup> = 50.85</p> <p>L3 <sup>1)</sup> = 60.30</p> <p><b>Stoßboden</b></p> <p>R = 1.30</p> <p>R1 = 12.00</p> <p>R2 =</p> <p>R3 =</p> <p>r =</p> <p><b>Pulverkammer</b></p> <p>E = 3.20</p> <p>P1 = 12.01</p> <p>P2 <sup>1)</sup> = 10.98</p> <p><b>Schulterkonus</b></p> <p>α <sup>1)</sup> = 38°20'</p> <p>S = 63.95</p> <p>r1 max = 0.50</p> <p>r2 = 0.50</p> <p><b>Hülsenhals</b></p> <p>H1 <sup>*</sup> = 9.11</p> <p>H2 <sup>1)</sup> = 9.10</p> <p><b>Geschossübergang</b></p> <p>G1 <sup>1)</sup>* = 8.23</p> <p>G <sup>1)</sup>* = 34.00</p> <p>α1 = 180°</p> <p>h =</p> <p>s =</p> <p>i <sup>1)</sup> = 0°17'11"</p> <p>w =</p> <p><b>Lauf</b></p> <p>F <sup>1)</sup>* = 7.89</p> <p>Z <sup>1)</sup> = 8.20</p> <p><b>Züge</b></p> <p>b = 4.40</p> <p>N = 4</p> <p>u = 240.00</p> <p>Q = 51.78 mm<sup>2</sup></p>	
<p>Maßstab 1:1.21</p> <p>Maße in &lt;&lt; mm &gt;&gt;</p> <p>Maße und Toleranzen für Messläufe siehe Anhang CR 1.</p>			<p>Bemerkungen: 1) Kontrolle aus Sicherheitsgründen * Grundmaße</p>	

<b>C.I.P.</b>	<b>8 x 64</b>		<b>TAB.</b>	<b>I</b>
	Ursprungsland: DE		Datum	84-06-14
			Revision	02-05-15
	<b>PATRONE MAXI</b>		<b>PATRONENLAGER MINI</b>	
	<p><b>Längen</b></p> <p>L1 <sup>1)</sup>* = 51.80 -0.20                  L2 <sup>1)</sup>* = 55.79 -0.20                  L3 <sup>1)</sup> = 63.70                  L4 =                  L5 =                  L6 = 86.00</p> <p><b>Hülsenboden</b></p> <p>R = 1.30                  R1 = 12.00                  R3 =                  E = 3.20                  E1 = 10.60                  e min = 1.00                  delta = 36°52'12"                  f = 0.30                  beta = 45°</p> <p><b>Pulverkammer</b></p> <p>P1 = 11.95                  P2 <sup>1)</sup>* = 10.85 -0.20</p> <p><b>Schulterkonus</b></p> <p>alpha = 28°00'18"                  S = 73.55                  r1 min = 0.50                  r2 = 0.50</p> <p><b>Hülsenhals</b></p> <p>H1 * = 8.86                  H2 <sup>1)</sup> = 8.86</p> <p><b>Geschoss</b></p> <p>G1 <sup>1)</sup> = 8.09                  G2 =                  F =                  L3+G <sup>1)</sup> = 97.70</p> <p><b>Drücke (Energien)</b></p> <p><b>Mech. elektr. Wandler</b></p> <p>Pmax = 4050 bar                  PK = 4658 bar                  PE = 5060 bar                  M = 25.00                  EE = 4375 Joule</p> <p><b>Verschiedene Daten</b></p> <p>Fe <sup>1)</sup> = 0.10                  delta L =</p>		<p><b>Längen</b></p> <p>L1 * = 51.74                  L2 * = 55.73                  L3 <sup>1)</sup> = 64.00</p> <p><b>Stoßboden</b></p> <p>R = 1.30                  R1 = 12.00                  R2 =                  R3 =                  r =</p> <p><b>Pulverkammer</b></p> <p>E = 3.20                  P1 <sup>1)</sup> = 11.96                  P2 * = 10.88</p> <p><b>Schulterkonus</b></p> <p>alpha <sup>1)</sup> = 28°00'18"                  S = 73.55                  r1 max = 0.50                  r2 = 0.50</p> <p><b>Hülsenhals</b></p> <p>H1 * = 8.89                  H2 <sup>1)</sup> = 8.88</p> <p><b>Geschossübergang</b></p> <p>G1 <sup>1)</sup>* = 8.14                  G <sup>1)</sup>* = 34.00                  alpha1 = 90°                  h * = 0.37                  s =                  i <sup>1)</sup> = 0°17'22"                  w =</p> <p><b>Lauf</b></p> <p>F <sup>1)</sup>* = 7.80                  Z <sup>1)</sup> = 8.07</p> <p><b>Züge</b></p> <p>b = 4.40                  N = 4                  u = 240.00                  Q = 50.30 mm<sup>2</sup></p>	
Maßstab 1:1.5  Maße in << mm >> Maße und Toleranzen für Messläufe siehe Anhang CR 1.		Bemerkungen: 1) Kontrolle aus Sicherheitsgründen * Grundmaße		

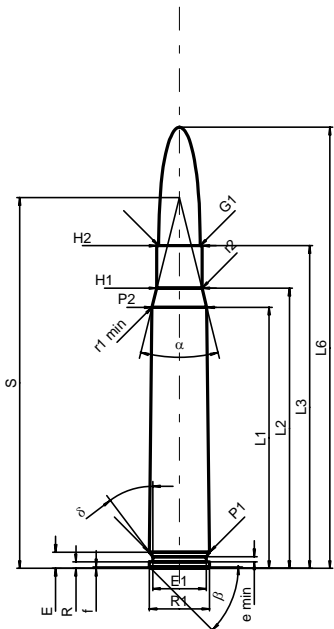
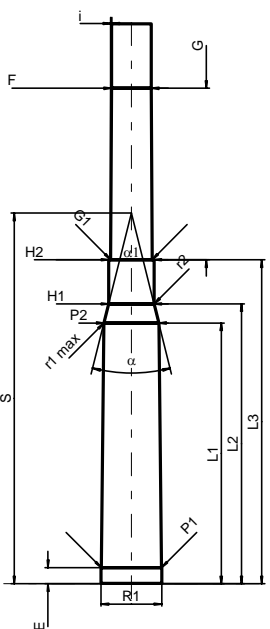
<h1>C.I.P.</h1>	<h2>8 x 64 S</h2>		TAB. <b>I</b>
	Ursprungsland: DE		<b>Datum</b> 84-06-14
			<b>Revision</b> 02-05-15
	<b>PATRONE MAXI</b>		<b>PATRONENLAGER MINI</b>
	<b>Längen</b> L1 <sup>1)*</sup> = 51.80 -0.20 L2 <sup>1)*</sup> = 55.59 -0.20 L3 <sup>1)</sup> = 64.00 L4 = L5 = 67.10 L6 = 87.50  <b>Hülsenboden</b> R = 1.30 R1 = 12.00 R3 = E = 3.20 E1 = 10.60 e min = 1.00 delta = 36°48' f = 0.30 beta = 45°  <b>Pulverkammer</b> P1 = 11.95 P2 <sup>1)*</sup> = 10.85 -0.20  <b>Schulterkonus</b> alpha = 28°00'05" S = 73.56 r1 min = 0.50 r2 = 0.50  <b>Hülsenhals</b> H1 * = 8.96 H2 <sup>1)</sup> = 8.96  <b>Geschoss</b> G1 <sup>1)</sup> = 8.22 G2 = 8.18 F = L3+G <sup>1)</sup> = 98.00  <b>Drücke (Energien)</b> <b>Mech. elektr. Wandler</b> Pmax = 4050 bar PK = 4658 bar PE = 5060 bar M = 25.00 EE = 4595 Joule  <b>Verschiedene Daten</b> Fe <sup>1)</sup> = 0.10 delta L =		<b>Längen</b> L1 * = 51.74 L2 * = 55.53 L3 <sup>1)</sup> = 64.30  <b>Stoßboden</b> R = 1.30 R1 = 12.05 R2 = R3 = r =  <b>Pulverkammer</b> E = 3.20 P1 <sup>1)</sup> = 11.98 P2 * = 10.88  <b>Schulterkonus</b> alpha <sup>1)</sup> = 28°00'05" S = 73.56 r1 max = 0.50 r2 = 0.50  <b>Hülsenhals</b> H1 * = 8.99 H2 <sup>1)</sup> = 8.98  <b>Geschossübergang</b> G1 <sup>1)*</sup> = 8.23 G <sup>1)*</sup> = 34.00 alpha1 = 180° h = s = i <sup>1)</sup> = 0°17'11" w =  <b>Lauf</b> F <sup>1)*</sup> = 7.89 Z <sup>1)</sup> = 8.20  <b>Züge</b> b = 4.40 N = 4 u = 240.00 Q = 51.78 mm <sup>2</sup>
			
	Maßstab 1:1.5  Maße in << mm >> Maße und Toleranzen für Messläufe siehe Anhang CR 1.		Bemerkungen: 1) Kontrolle aus Sicherheitsgründen * Grundmaße

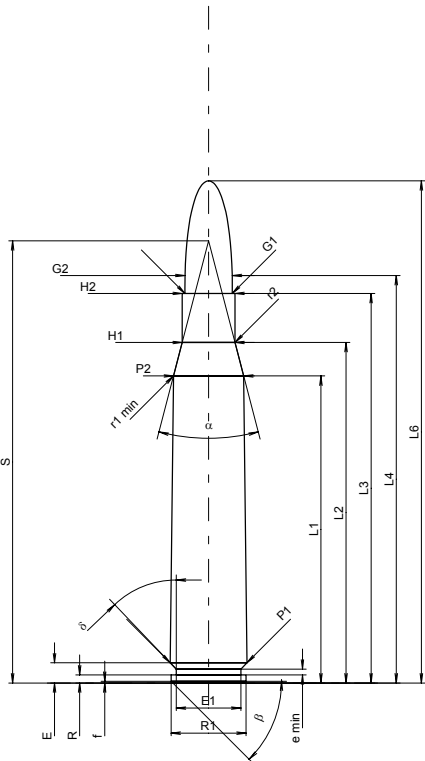
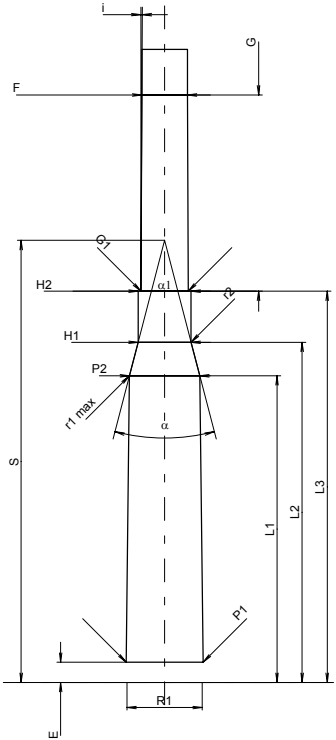
<b>C.I.P.</b>	<b>8 x 68 S</b>		<b>TAB.</b>	<b>I</b>
	Ursprungsland: DE		Datum	84-06-14
			Revision	06-09-19
	<b>PATRONE MAXI</b>		<b>PATRONENLAGER MINI</b>	
	<p><b>Längen</b></p> <p>L1 <sup>1)</sup>* = 53.20 -0.20                  L2 <sup>1)</sup>* = 59.00 -0.20                  L3 <sup>1)</sup> = 67.50                  L4 = 70.60                  L5 =                  L6 = 87.00</p> <p><b>Hülsenboden</b></p> <p>R = 1.40                  R1 = 13.00                  R3 =                  E = 3.50                  E1 = 11.20                  e min = 1.00                  δ = 43°42'                  f = 0.30                  β = 45°</p> <p><b>Pulverkammer</b></p> <p>P1 = 13.30                  P2 <sup>1)</sup>* = 12.15 -0.20</p> <p><b>Schulterkonus</b></p> <p>α = 29°05'34"                  S = 76.61                  r1 min = 0.50                  r2 = 0.50</p> <p><b>Hülsenhals</b></p> <p>H1 <sup>*</sup> = 9.14                  H2 <sup>1)</sup> = 9.14</p> <p><b>Geschoss</b></p> <p>G1 <sup>1)</sup> = 8.22                  G2 = 8.18                  F =                  L3+G <sup>1)</sup> = 101.50</p> <p><b>Drücke (Energien)</b></p> <p><b>Mech. elektr. Wandler</b></p> <p>Pmax = 4400 bar                  PK = 5060 bar                  PE = 5500 bar                  M = 25.00                  EE = 5975 Joule</p> <p><b>Verschiedene Daten</b></p> <p>Fe <sup>1)</sup> = 0.10                  delta L =</p>		<p><b>Längen</b></p> <p>L1 <sup>*</sup> = 53.14                  L2 <sup>*</sup> = 58.94                  L3 <sup>1)</sup> = 67.80</p> <p><b>Stoßboden</b></p> <p>R = 1.40                  R1 = 13.05                  R2 =                  R3 =                  r =</p> <p><b>Pulverkammer</b></p> <p>E = 3.50                  P1 <sup>1)</sup> = 13.33                  P2 <sup>*</sup> = 12.18</p> <p><b>Schulterkonus</b></p> <p>α <sup>1)</sup> = 29°05'34"                  S = 76.61                  r1 max = 0.50                  r2 = 0.50</p> <p><b>Hülsenhals</b></p> <p>H1 <sup>*</sup> = 9.17                  H2 <sup>1)</sup> = 9.16</p> <p><b>Geschossübergang</b></p> <p>G1 <sup>1)</sup>* = 8.23                  G <sup>1)</sup>* = 34.00                  α1 = 180°                  h =                  s =                  i <sup>1)</sup> = 0°17'11"                  w =</p> <p><b>Lauf</b></p> <p>F <sup>1)</sup>* = 7.89                  Z <sup>1)</sup> = 8.20</p> <p><b>Züge</b></p> <p>b = 4.40                  N = 4                  u = 280.00                  Q = 51.78 mm<sup>2</sup></p>	
	<p>Maßstab 1:1.31</p> <p style="text-align: center;">Maße in &lt;&lt; mm &gt;&gt;                  Maße und Toleranzen für Messläufe                  siehe Anhang CR 1.</p>			
		<p>Bemerkungen: 1) Kontrolle aus Sicherheitsgründen * Grundmaße</p>		

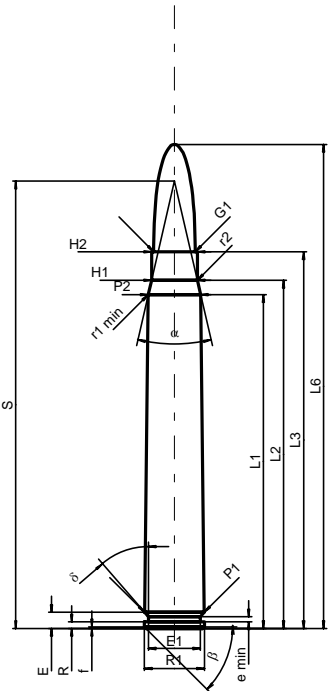
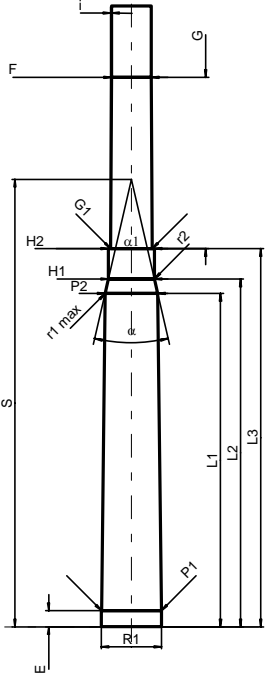
<b>C.I.P.</b>	<b>8 x 75 S</b>		<b>TAB.</b>	<b>I</b>
	Ursprungsland: DE		<b>Datum</b>	<b>84-06-14</b>
			<b>Revision</b>	<b>02-05-15</b>
	<b>PATRONE MAXI</b>		<b>PATRONENLAGER MINI</b>	
	<p><b>Längen</b></p> <p>L1 <sup>1)</sup>* = 66.20 -0.20</p> <p>L2 <sup>1)</sup>* = 69.06 -0.20</p> <p>L3 <sup>1)</sup> = 74.70</p> <p>L4 =</p> <p>L5 =</p> <p>L6 = 96.00</p> <p><b>Hülsenboden</b></p> <p>R = 1.30</p> <p>R1 = 11.90</p> <p>R3 =</p> <p>E = 3.20</p> <p>E1 = 10.30</p> <p>e min = 1.00</p> <p>δ = 40°54'</p> <p>f = 0.30</p> <p>β = 45°</p> <p><b>Pulverkammer</b></p> <p>P1 = 11.86</p> <p>P2 <sup>1)</sup>* = 10.40 -0.20</p> <p><b>Schulterkonus</b></p> <p>α = 25°59'21"</p> <p>S = 88.73</p> <p>r1 min = 0.50</p> <p>r2 = 0.50</p> <p><b>Hülsenhals</b></p> <p>H1 * = 9.08</p> <p>H2 <sup>1)</sup> = 9.08</p> <p><b>Geschoss</b></p> <p>G1 <sup>1)</sup> = 8.22</p> <p>G2 =</p> <p>F =</p> <p>L3+G <sup>1)</sup> = 108.70</p> <p><b>Drücke (Energien)</b></p> <p><b>Mech. elektr. Wandler</b></p> <p>Pmax = 4400 bar</p> <p>PK = 5060 bar</p> <p>PE = 5500 bar</p> <p>M = 25.00</p> <p>EE = 4750 Joule</p> <p><b>Verschiedene Daten</b></p> <p>Fe <sup>1)</sup> = 0.10</p> <p>delta L =</p>		<p><b>Längen</b></p> <p>L1 * = 66.13</p> <p>L2 * = 68.99</p> <p>L3 <sup>1)</sup> = 75.00</p> <p><b>Stoßboden</b></p> <p>R = 1.30</p> <p>R1 = 11.95</p> <p>R2 =</p> <p>R3 =</p> <p>r =</p> <p><b>Pulverkammer</b></p> <p>E = 3.20</p> <p>P1 <sup>1)</sup> = 11.89</p> <p>P2 * = 10.43</p> <p><b>Schulterkonus</b></p> <p>α <sup>1)</sup> = 25°59'21"</p> <p>S = 88.73</p> <p>r1 max = 0.50</p> <p>r2 = 0.50</p> <p><b>Hülsenhals</b></p> <p>H1 * = 9.11</p> <p>H2 <sup>1)</sup> = 9.10</p> <p><b>Geschossübergang</b></p> <p>G1 <sup>1)</sup>* = 8.23</p> <p>G <sup>1)</sup>* = 34.00</p> <p>α1 = 180°</p> <p>h =</p> <p>s =</p> <p>i <sup>1)</sup> = 0°17'11"</p> <p>w =</p> <p><b>Lauf</b></p> <p>F <sup>1)</sup>* = 7.89</p> <p>Z <sup>1)</sup> = 8.20</p> <p><b>Züge</b></p> <p>b = 4.40</p> <p>N = 4</p> <p>u = 240.00</p> <p>Q = 51.78 mm<sup>2</sup></p>	
				
Maßstab 1:1.5				
<p>Maße in &lt;&lt; mm &gt;&gt;</p> <p>Maße und Toleranzen für Messläufe siehe Anhang CR 1.</p>	<p>Bemerkungen: 1) Kontrolle aus Sicherheitsgründen * Grundmaße</p>			

<b>C.I.P.</b>	<b>8,5 x 63</b>		TAB.	I
			Datum	92-02-27
	Ursprungsland: DE		Revision	06-01-24
	<b>PATRONE MAXI</b>		<b>PATRONENLAGER MINI</b>	
	<b>Längen</b> L1 <sup>1)</sup> * = 53.42 -0.20 L2 <sup>1)</sup> * = 54.69 -0.20 L3 <sup>1)</sup> = 63.00 L4 = L5 = L6 = 84.00 <b>Hülisenboden</b> R = 1.24 R1 = 12.01 R3 = E = 3.20 E1 = 10.40 e min = 1.00 δ = 37°48'36" f = 0.30 β = 45° <b>Pulverkammer</b> P1 = 11.89 P2 <sup>1)</sup> * = 11.47 -0.20 <b>Schulterkonus</b> α = 80°13'46" S = 60.23 r1 min = r2 = <b>Hülisenhals</b> H1 * = 9.33 H2 <sup>1)</sup> = 9.32 <b>Geschoss</b> G1 <sup>1)</sup> = 8.59 G2 = F = L3+G <sup>1)</sup> = 72.00 <b>Drücke (Energien)</b> <b>Mech. elektr. Wandler</b> Pmax = 4300 bar PK = 4945 bar PE = 5375 bar M = 25.00 EE = 5540 Joule <b>Verschiedene Daten</b> Fe <sup>1)</sup> = 0.10 delta L =		<b>Längen</b> L1 * = 53.40 L2 * = 54.67 L3 <sup>1)</sup> = 63.55 <b>Stoßboden</b> R = 1.24 R1 = 12.04 R2 = R3 = r = <b>Pulverkammer</b> E = 3.20 P1 <sup>1)</sup> = 11.92 P2 * = 11.50 <b>Schulterkonus</b> α <sup>1)</sup> = 80°13'46" S = 60.22 r1 max = r2 = <b>Hülisenhals</b> H1 * = 9.36 H2 <sup>1)</sup> = 9.35 <b>Geschossübergang</b> G1 <sup>1)</sup> * = 8.61 G <sup>1)</sup> * = 9.00 α1 = 90° h = 0.38 s * = 5.83 i <sup>1)</sup> = 1°53'49" w = <b>Lauf</b> F <sup>1)</sup> * = 8.38 Z <sup>1)</sup> = 8.59 <b>Züge</b> b = 2.79 N = 6 u = 254.00 Q = 56.95 mm <sup>2</sup>	
	Maßstab 1:1  Maße in << mm >> Maße und Toleranzen für Messläufe siehe Anhang CR 1.		Bemerkungen: 1) Kontrolle aus Sicherheitsgründen * Grundmaße	

C.I.P.	8,5 x 68 Fanzoj		TAB.	I
	Ursprungsland: DE		Datum	12-05-30
			Revision	
	<b>PATRONE MAXI</b> <b>Längen</b> L1 <sup>1)</sup> = 53.20 -0.20 L2 <sup>1)</sup> = 58.40 -0.20 L3 <sup>1)</sup> = 67.50 L4 = L5 = L6 = 87.00 <b>Hülsenboden</b> R = 1.40 R1 = 13.00 R3 = E = 3.50 E1 = 11.20 e min = 1.00 δ = 43°42' f = 0.30 β = 45° <b>Pulverkammer</b> P1 = 13.30 P2 <sup>1)</sup> * = 12.15 -0.20 <b>Schulterkonus</b> α * = 29°06'26" S * = 76.60 r1 min = 0.50 r2 = 3.00 <b>Hülsenhals</b> H1 * = 9.45 H2 <sup>1)</sup> = 9.45 <b>Geschoss</b> G1 <sup>1)</sup> = 8.59 G2 = F = L3+G <sup>1)</sup> = 73.70 <b>Drücke (Energien)</b> <b>Mech. elektr. Wandler</b> Pmax = 4400 bar PK = 5060 bar PE = 5500 bar M = 25.00 EE = 5975 Joule <b>Verschiedene Daten</b> Fe <sup>1)3)</sup> = 0.10 delta L =		<b>PATRONENLAGER MINI</b> <b>Längen</b> L1 = 53.14 L2 = 58.32 L3 <sup>1)</sup> = 67.80 <b>Stoßboden</b> R = 1.40 R1 = 13.05 R2 = R3 = r = <b>Pulverkammer</b> E = 3.50 P1 <sup>1)</sup> = 13.33 P2 * = 12.18 <b>Schulterkonus</b> α <sup>1)</sup> * = 29°06'40" S * = 76.59 r1 max = 0.50 r2 = 3.00 <b>Hülsenhals</b> H1 * = 9.49 H2 <sup>1)</sup> = 9.49 <b>Geschossübergang</b> G1 <sup>1)</sup> * = 8.60 G <sup>1)</sup> = 6.20 α1 = 90° h = 0.45 s * = 2.00 i <sup>1)</sup> * = 1°30' w = <b>Lauf</b> F <sup>1)</sup> * = 8.38 Z <sup>1)</sup> = 8.59 <b>Züge</b> b = 2.79 N = 6 u = 254.00 Q = 56.95 mm <sup>2</sup>	
Maßstab 1:1.06  Maße in << mm >> Maße und Toleranzen für Messläufe siehe Anhang CR1.	Bemerkungen: 1) Kontrolle aus Sicherheitsgründen 3) Verschlussabstand an Schulter * Grundmaße			

C.I.P.	8,5 mm Messner Mag.	TAB.	I
		Datum	13-05-22
		Revision	
Ursprungsland: FR			
	<b>PATRONE MAXI</b>		<b>PATRONENLAGER MINI</b>
	<p><b>Längen</b></p> <p>L1 <sup>1)</sup> = 50.88 -0.20                      L2 <sup>1)</sup> = 55.01 -0.20                      L3 <sup>1)</sup> = 63.85                      L4 =                      L5 =                      L6 = 88.00</p> <p><b>Hülsenboden</b></p> <p>R = 1.38                      R1 = 13.60                      R3 =                      E = 3.48                      E1 = 12.19                      e min = 1.02                      δ = 45°                      f = 0.36                      β = 35°</p> <p><b>Pulverkammer</b></p> <p>P1 = 14.35                      P2 <sup>1)</sup>* = 13.93 -0.20</p> <p><b>Schulterkonus</b></p> <p>α * = 58°                      S * = 63.44                      r1 min = 0.66                      r2 = 1.85</p> <p><b>Hülsenhals</b></p> <p>H1 * = 9.35                      H2 <sup>1)</sup> = 9.35</p> <p><b>Geschoss</b></p> <p>G1 <sup>1)</sup> = 8.59                      G2 =                      F =                      L3+G <sup>1)</sup> = 75.10</p> <p><b>Drücke (Energien)</b></p> <p><b>Mech. elektr. Wandler</b></p> <p>Pmax = 4400 bar                      PK = 5060 bar                      PE = 5500 bar                      M = 25.00                      EE = 6400 Joule</p> <p><b>Verschiedene Daten</b></p> <p>Fe <sup>1)3)</sup> = 0.10                      delta L =</p>		<p><b>Längen</b></p> <p>L1 = 50.85                      L2 = 54.98                      L3 <sup>1)</sup> = 64.10</p> <p><b>Stoßboden</b></p> <p>R = 1.38                      R1 = 13.62                      R2 =                      R3 =                      r =</p> <p><b>Pulverkammer</b></p> <p>E = 3.35                      P1 <sup>1)</sup> = 14.38                      P2 * = 13.96</p> <p><b>Schulterkonus</b></p> <p>α <sup>1)</sup>* = 58°                      S * = 63.44                      r1 max = 0.55                      r2 = 2.22</p> <p><b>Hülsenhals</b></p> <p>H1 * = 9.38                      H2 <sup>1)</sup> = 9.38</p> <p><b>Geschossübergang</b></p> <p>G1 <sup>1)</sup> = 8.61                      G <sup>1)</sup>* = 11.25                      α1 = 90°                      h = 0.39                      s * = 7.81                      i <sup>1)</sup>* = 1°54'53"                      w =</p> <p><b>Lauf</b></p> <p>F <sup>1)</sup>* = 8.38                      Z <sup>1)</sup> = 8.59</p> <p><b>Züge</b></p> <p>b = 2.79                      N = 6                      u = 254.00                      Q = 56.95 mm<sup>2</sup></p>
<p>Maßstab 1:1.07</p> <p>Maße in &lt;&lt; mm &gt;&gt; Maße und Toleranzen für Messläufe siehe Anhang CR 1.</p>		<p>Bemerkungen: 1) Kontrolle aus Sicherheitsgründen                      3) Verschlussabstand an Schulter                      * Grundmaße</p>	



<b>C.I.P.</b>	<b>9 x 56 Mannl. Sch.</b>  Ursprungsland: AT	<b>TAB.</b>	<b>I</b>
		<b>Datum</b>	<b>95-06-28</b>
		<b>Revision</b>	<b>05-07-01</b>
	<p><b>PATRONE MAXI</b></p> <p><b>Längen</b></p> <p>L1 <sup>1)</sup>* = 46.48 -0.20                  L2 <sup>1)</sup>* = 48.00 -0.20                  L3 <sup>1)</sup> = 56.30                  L4 =                  L5 =                  L6 = 81.00</p> <p><b>Hülsenboden</b></p> <p>R = 1.20                  R1 = 11.90                  R3 =                  E = 3.20                  E1 = 10.30                  e min = 1.00                  delta = 36°52'12"                  f = 0.30                  beta = 45°</p> <p><b>Pulverkammer</b></p> <p>P1 = 11.80                  P2 <sup>1)</sup>* = 10.70 -0.20</p> <p><b>Schulterkonus</b></p> <p>alpha = 38°06'33"                  S = 61.97                  r1 min = 0.50                  r2 = 0.50</p> <p><b>Hülsenhals</b></p> <p>H1* = 9.65                  H2 <sup>1)</sup> = 9.65</p> <p><b>Geschoss</b></p> <p>G1 <sup>1)</sup> = 9.08                  G2 =                  F =                  L3+G <sup>1)</sup> = 71.50</p> <p><b>Drücke (Energien)</b>  <b>Mech. elektr. Wandler</b></p> <p>Pmax = 2080 bar                  PK = 2392 bar                  PE = 2600 bar                  M = 25.00                  EE = 2815 Joule</p> <p><b>Verschiedene Daten</b></p> <p>Fe <sup>1)</sup> = 0.15                  delta L =</p>	<p><b>PATRONE MIN</b></p> <p><b>Längen</b></p> <p>L1* = 46.41                  L2* = 47.93                  L3 <sup>1)</sup> = 56.80</p> <p><b>Stoßboden</b></p> <p>R = 1.20                  R1 = 11.95                  R2 =                  R3 =                  r =</p> <p><b>Pulverkammer</b></p> <p>E = 3.20                  P1 <sup>1)</sup> = 11.85                  P2* = 10.75</p> <p><b>Schulterkonus</b></p> <p>alpha <sup>1)</sup> = 38°06'33"                  S = 61.97                  r1 max = 0.50                  r2 = 0.50</p> <p><b>Hülsenhals</b></p> <p>H1* = 9.70                  H2 <sup>1)</sup> = 9.68</p> <p><b>Geschossübergang</b></p> <p>G1 <sup>1)</sup>* = 9.18                  G <sup>1)</sup>* = 15.20                  alpha1 = 180°                  h =                  s =                  i <sup>1)</sup> = 0°42'58"                  w =</p> <p><b>Lauf</b></p> <p>F <sup>1)</sup>* = 8.80                  Z <sup>1)</sup> = 9.15</p> <p><b>Züge</b></p> <p>b = 4.40                  N = 4                  u = 280.00                  Q = 64.04 mm<sup>2</sup></p>	
<p>Maßstab 1:1</p> <p>Maße in &lt;&lt; mm &gt;&gt;                  Maße und Toleranzen für Messläufe                  siehe Anhang CR 1.</p>	<p>Bemerkungen: 1) Kontrolle aus Sicherheitsgründen                  * Grundmaße</p>		

<b>C.I.P.</b>	<b>9 x 57</b>		<b>TAB.</b>	<b>I</b>
	Ursprungsland: DE		<b>Datum</b>	<b>84-06-14</b>
			<b>Revision</b>	<b>04-05-18</b>
	<b>PATRONE MAXI</b>		<b>PATRONENLAGER MINI</b>	
	<p><b>Längen</b></p> <p>L1 <sup>1)</sup>* = 46.20 -0.20</p> <p>L2 <sup>1)</sup>* = 47.82 -0.20</p> <p>L3 <sup>1)</sup> = 56.80</p> <p>L4 =</p> <p>L5 =</p> <p>L6 = 81.00</p> <p><b>Hülsenboden</b></p> <p>R = 1.30</p> <p>R1 = 11.95</p> <p>R3 =</p> <p>E = 3.20</p> <p>E1 = 10.50</p> <p>e min = 1.00</p> <p>δ = 38°39'35"</p> <p>f = 0.30</p> <p>β = 45°</p> <p><b>Pulverkammer</b></p> <p>P1 = 11.94</p> <p>P2 <sup>1)</sup>* = 10.95 -0.20</p> <p><b>Schulterkonus</b></p> <p>α = 38°08'18"</p> <p>S = 62.04</p> <p>r1 min = 0.50</p> <p>r2 = 0.50</p> <p><b>Hülsenhals</b></p> <p>H1 * = 9.83</p> <p>H2 <sup>1)</sup> = 9.83</p> <p><b>Geschoss</b></p> <p>G1 <sup>1)</sup> = 9.08</p> <p>G2 =</p> <p>F =</p> <p>L3+G <sup>1)</sup> = 90.10</p> <p><b>Drücke (Energien)</b></p> <p><b>Mech. elektr. Wandler</b></p> <p>Pmax = 2800 bar</p> <p>PK = 3220 bar</p> <p>PE = 3500 bar</p> <p>M = 25.00</p> <p>EE = 3650 Joule</p> <p><b>Verschiedene Daten</b></p> <p>Fe <sup>1)</sup> = 0.15</p> <p>delta L =</p>		<p><b>Längen</b></p> <p>L1 * = 46.16</p> <p>L2 * = 47.74</p> <p>L3 <sup>1)</sup> = 57.10</p> <p><b>Stoßboden</b></p> <p>R = 1.30</p> <p>R1 = 12.00</p> <p>R2 =</p> <p>R3 =</p> <p>r =</p> <p><b>Pulverkammer</b></p> <p>E = 3.20</p> <p>P1 <sup>1)</sup> = 11.97</p> <p>P2 * = 10.98</p> <p><b>Schulterkonus</b></p> <p>α <sup>1)</sup> = 38°23'10"</p> <p>S = 61.93</p> <p>r1 max = 0.50</p> <p>r2 = 0.50</p> <p><b>Hülsenhals</b></p> <p>H1 * = 9.88</p> <p>H2 <sup>1)</sup> = 9.87</p> <p><b>Geschossübergang</b></p> <p>G1 <sup>1)</sup>* = 9.15</p> <p>G <sup>1)</sup>* = 33.30</p> <p>α1 = 90°</p> <p>h = 0.36</p> <p>s =</p> <p>i <sup>1)</sup> = 0°19'06"</p> <p>w =</p> <p><b>Lauf</b></p> <p>F <sup>1)</sup>* = 8.78</p> <p>Z <sup>1)</sup> = 9.06</p> <p><b>Züge</b></p> <p>b = 4.60</p> <p>N = 4</p> <p>u = 360.00</p> <p>Q = 63.25 mm<sup>2</sup></p>	
Maßstab 1:1.5				
<p>Maße in &lt;&lt; mm &gt;&gt;</p> <p>Maße und Toleranzen für Messläufe siehe Anhang CR 1.</p>		<p>Bemerkungen: 1) Kontrolle aus Sicherheitsgründen * Grundmaße</p>		

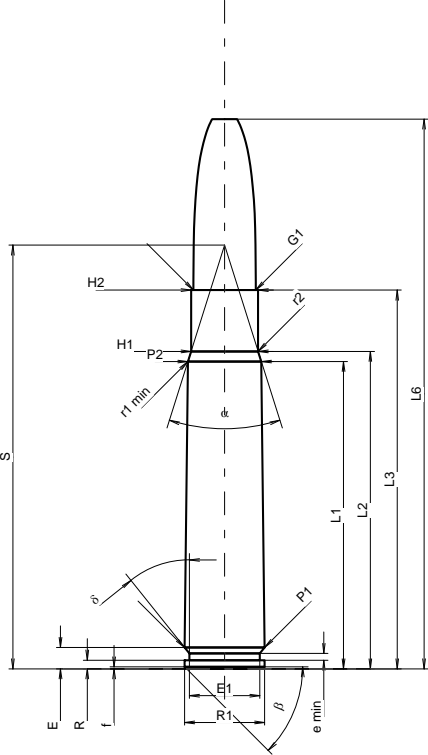
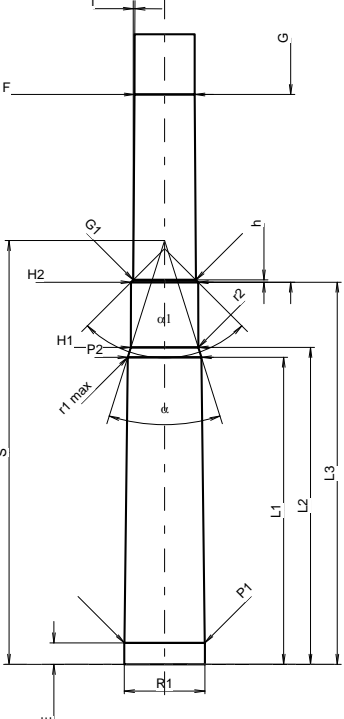
<b>C.I.P.</b>	<b>9,3 x 57</b>		<b>TAB.</b>	<b>I</b>
			<b>Datum</b>	<b>07-05-14</b>
	Ursprungsland: DE		<b>Revision</b>	<b>11-05-25</b>
	<b>PATRONE MAXI</b>		<b>PATRONENLAGER MINI</b>	
	<b>Längen</b> L1 <sup>1)</sup> = 45.85 -0.20 L2 <sup>1)</sup> = 47.36 -0.20 L3 <sup>1)</sup> = 56.50 L4 = L5 = L6 = 82.00  <b>Hülsenboden</b> R = 1.30 R1 = 11.95 R3 = E = 3.20 E1 = 10.50 e min = 1.00 δ = 38°39'36" f = 0.30 β = 45°  <b>Pulverkammer</b> P1 = 11.94 P2 <sup>1)</sup> * = 10.95 -0.20  <b>Schulterkonus</b> α * = 35° S * = 63.22 r1 min = 0.50 r2 = 0.50  <b>Hülsenhals</b> H1 * = 10.00 H2 <sup>1)</sup> = 10.00  <b>Geschoss</b> G1 <sup>1)</sup> = 9.30 G2 = F = L3+G <sup>1)</sup> = 84.50  <b>Drücke (Energien)</b> <b>Crusher-Methode</b> Pmax = 3000 bar PK = 3450 bar PE = 3750 bar M = 25.00 EE = 4250 Joule  <b>Verschiedene Daten</b> Fe <sup>1)3)</sup> = 0.15 delta L =		<b>Längen</b> L1 = 45.81 L2 = 47.28 L3 <sup>1)</sup> = 57.00  <b>Stoßboden</b> R = 1.30 R1 = 12.00 R2 = R3 = r =  <b>Pulverkammer</b> E = 3.20 P1 <sup>1)</sup> = 11.97 P2 * = 10.98  <b>Schulterkonus</b> α <sup>1)</sup> * = 35° S * = 63.22 r1 max = 0.50 r2 = 0.50  <b>Hülsenhals</b> H1 * = 10.05 H2 <sup>1)</sup> = 10.03  <b>Geschossübergang</b> G1 <sup>1)</sup> * = 9.35 G <sup>1)</sup> = 28.00 α1 <sup>1)</sup> = 90° h = 0.34 s = i <sup>1)</sup> * = 0°21'45" w =  <b>Lauf</b> F <sup>1)</sup> * = 9.00 Z <sup>1)</sup> = 9.28  <b>Züge</b> b = 4.60 N = 4 u = 360.00 Q = 66.32 mm <sup>2</sup>	
	Maßstab 1:1.13  Maße in << mm >> Maße und Toleranzen für Messläufe siehe Anhang CR 1.		Bemerkungen: 1) Kontrolle aus Sicherheitsgründen 3) Verschlussabstand an Schulter * Grundmaße	

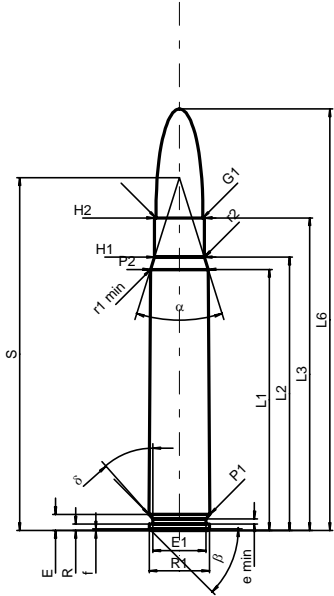
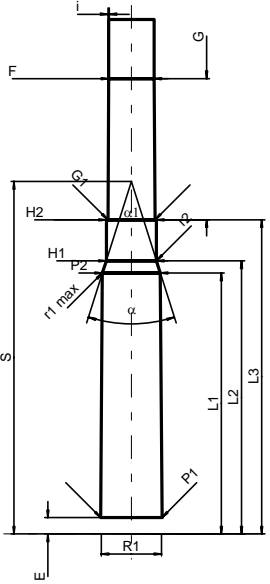
<b>C.I.P.</b>	<b>9,3 x 62</b>		<b>TAB.</b>	<b>I</b>
	Ursprungsland: DE		<b>Datum</b>	<b>84-06-14</b>
			<b>Revision</b>	<b>02-05-15</b>
	<b>PATRONE MAXI</b>		<b>PATRONENLAGER MINI</b>	
	<p><b>Längen</b></p> <p>L1 <sup>1)</sup>* = 51.79 -0.20                      L2 <sup>1)</sup>* = 54.22 -0.20                      L3 <sup>1)</sup> = 62.00                      L4 =                      L5 = 65.10                      L6 = 83.60</p> <p><b>Hülsenboden</b></p> <p>R = 1.30                      R1 = 11.95                      R3 =                      E = 3.20                      E1 = 10.50                      e min = 1.00                      delta = 41°37'48"                      f = 0.30                      beta = 45°</p> <p><b>Pulverkammer</b></p> <p>P1 = 12.10                      P2 <sup>1)</sup>* = 11.45 -0.20</p> <p><b>Schulterkonus</b></p> <p>alpha = 34°56'58"                      S = 69.98                      r1 min = 0.50                      r2 = 0.50</p> <p><b>Hülsenhals</b></p> <p>H1 * = 9.92                      H2 <sup>1)</sup> = 9.92</p> <p><b>Geschoss</b></p> <p>G1 <sup>1)</sup> = 9.30                      G2 = 9.30                      F =                      L3+G <sup>1)</sup> = 90.00</p> <p><b>Drücke (Energien)</b></p> <p><b>Mech. elektr. Wandler</b></p> <p>Pmax = 3900 bar                      PK = 4485 bar                      PE = 4875 bar                      M = 25.00                      EE = 5335 Joule</p> <p><b>Verschiedene Daten</b></p> <p>Fe <sup>1)</sup> = 0.10                      delta L =</p>		<p><b>Längen</b></p> <p>L1 * = 51.75                      L2 * = 54.17                      L3 <sup>1)</sup> = 62.30</p> <p><b>Stoßboden</b></p> <p>R = 1.30                      R1 = 12.00                      R2 =                      R3 =                      r =</p> <p><b>Pulverkammer</b></p> <p>E = 3.20                      P1 <sup>1)</sup> = 12.13                      P2 * = 11.48</p> <p><b>Schulterkonus</b></p> <p>alpha <sup>1)</sup> = 35°05'06"                      S = 69.91                      r1 max = 0.50                      r2 = 0.50</p> <p><b>Hülsenhals</b></p> <p>H1 * = 9.95                      H2 <sup>1)</sup> = 9.94</p> <p><b>Geschossübergang</b></p> <p>G1 <sup>1)</sup>* = 9.35                      G <sup>1)</sup>* = 28.00                      alpha1 = 180°                      h =                      s =                      i <sup>1)</sup> = 0°21'29"                      w =</p> <p><b>Lauf</b></p> <p>F <sup>1)</sup>* = 9.00                      Z <sup>1)</sup> = 9.28</p> <p><b>Züge</b></p> <p>b = 4.60                      N = 4                      u = 360.00                      Q = 66.32 mm<sup>2</sup></p>	
				
<p>Maßstab 1:1.5</p> <p>Maße in &lt;&lt; mm &gt;&gt;                      Maße und Toleranzen für Messläufe                      siehe Anhang CR 1.</p>		<p>Bemerkungen: 1) Kontrolle aus Sicherheitsgründen                      * Grundmaße</p>		

<b>C.I.P.</b>	<b>9,3 x 64 Brenneke</b> Ursprungsland: DE	TAB. <b>I</b>
		Datum <b>84-06-14</b>
		Revision <b>02-05-15</b>
	<b>PATRONE MAXI</b>	<b>PATRONENLAGER MINI</b>
	<p><b>Längen</b></p> <p>L1 <sup>1)</sup>* = 52.09 -0.20                  L2 <sup>1)</sup>* = 55.28 -0.20                  L3 <sup>1)</sup> = 64.00                  L4 =                  L5 = 70.00                  L6 = 85.60</p> <p><b>Hülsenboden</b></p> <p>R = 1.30                  R1 = 12.60                  R3 =                  E = 3.20                  E1 = 11.20                  e min = 1.00                  delta = 43°                  f = 0.30                  beta = 45°</p> <p><b>Pulverkammer</b></p> <p>P1 = 12.88                  P2 <sup>1)</sup>* = 12.05 -0.20</p> <p><b>Schulterkonus</b></p> <p>alpha = 34°58'26"                  S = 71.21                  r1 min = 0.50                  r2 = 0.50</p> <p><b>Hülsenhals</b></p> <p>H1 * = 10.04                  H2 <sup>1)</sup> = 10.04</p> <p><b>Geschoss</b></p> <p>G1 <sup>1)</sup> = 9.30                  G2 = 9.25                  F =                  L3+G <sup>1)</sup> = 92.00</p> <p><b>Drücke (Energien)</b></p> <p><b>Mech. elektr. Wandler</b></p> <p>Pmax = 4400 bar                  PK = 5060 bar                  PE = 5500 bar                  M = 25.00                  EE = 5335 Joule</p> <p><b>Verschiedene Daten</b></p> <p>Fe <sup>1)</sup> = 0.10                  delta L =</p>	<p><b>Längen</b></p> <p>L1 * = 52.04                  L2 * = 55.23                  L3 <sup>1)</sup> = 64.30</p> <p><b>Stoßboden</b></p> <p>R = 1.30                  R1 = 12.65                  R2 =                  R3 =                  r =</p> <p><b>Pulverkammer</b></p> <p>E = 3.20                  P1 <sup>1)</sup> = 12.91                  P2 * = 12.08</p> <p><b>Schulterkonus</b></p> <p>alpha <sup>1)</sup> = 34°58'26"                  S = 71.21                  r1 max = 0.50                  r2 = 0.50</p> <p><b>Hülsenhals</b></p> <p>H1 * = 10.07                  H2 <sup>1)</sup> = 10.06</p> <p><b>Geschossübergang</b></p> <p>G1 <sup>1)</sup>* = 9.35                  G <sup>1)</sup>* = 28.00                  alpha1 = 180°                  h =                  s =                  i <sup>1)</sup> = 0°21'29"                  w =</p> <p><b>Lauf</b></p> <p>F <sup>1)</sup>* = 9.00                  Z <sup>1)</sup> = 9.28</p> <p><b>Züge</b></p> <p>b = 4.60                  N = 4                  u = 360.00                  Q = 66.32 mm<sup>2</sup></p>
	<p>Maßstab 1:1.5</p> <p>Maße in &lt;&lt; mm &gt;&gt;                  Maße und Toleranzen für Messläufe                  siehe Anhang CR 1.</p>	
		<p>Bemerkungen: 1) Kontrolle aus Sicherheitsgründen                  * Grundmaße</p>

<b>C.I.P.</b>	<b>9,3 x 66 Sako</b>  Ursprungsland: FI	TAB.	I
		Datum	02-01-22
		Revision	02-05-15
	<b>PATRONE MAXI</b>	<b>PATRONENLAGER MINI</b>	
	<p><b>Längen</b></p> <p>L1 <sup>1)</sup>* = 55.80 -0.20                  L2 <sup>1)</sup>* = 58.20 -0.20                  L3 <sup>1)</sup> = 66.00                  L4 =                  L5 =                  L6 = 85.00</p> <p><b>Hülsenboden</b></p> <p>R = 1.30                  R1 = 11.95                  R3 =                  E = 3.24                  E1 = 10.50                  e min = 1.00                  δ = 41°                  f = 0.30                  β = 45°</p> <p><b>Pulverkammer</b></p> <p>P1 = 12.13                  P2 <sup>1)</sup>* = 11.43 -0.20</p> <p><b>Schulterkonus</b></p> <p>α = 34°55'31"                  S = 73.97                  r1 min = 0.50                  r2 = 0.50</p> <p><b>Hülsenhals</b></p> <p>H1* = 9.92                  H2 <sup>1)</sup> = 9.92</p> <p><b>Geschoss</b></p> <p>G1 <sup>1)</sup> = 9.30                  G2 =                  F =                  L3+G <sup>1)</sup> = 83.01</p> <p><b>Drücke (Energien)</b>  <b>Mech. elektr. Wandler</b></p> <p>Pmax = 4150 bar                  PK = 4773 bar                  PE = 5188 bar                  M = 25.00                  EE = 6000 Joule</p> <p><b>Verschiedene Daten</b></p> <p>Fe <sup>1)</sup> = 0.10                  delta L =</p>	<p><b>Längen</b></p> <p>L1* = 55.75                  L2* = 58.17                  L3 <sup>1)</sup> = 66.30</p> <p><b>Stoßboden</b></p> <p>R =                  R1 = 12.00                  R2 =                  R3 =                  r =</p> <p><b>Pulverkammer</b></p> <p>E = 3.24                  P1 <sup>1)</sup> = 12.18                  P2* = 11.48</p> <p><b>Schulterkonus</b></p> <p>α <sup>1)</sup> = 35°05'06"                  S = 73.91                  r1 max = 0.50                  r2 = 0.50</p> <p><b>Hülsenhals</b></p> <p>H1* = 9.95                  H2 <sup>1)</sup> = 9.94</p> <p><b>Geschossübergang</b></p> <p>G1 <sup>1)</sup>* = 9.35                  G <sup>1)</sup>* = 17.01                  α1 = 89°02'13"                  h* = 0.30                  s =                  i <sup>1)</sup> = 0°36'                  w =</p> <p><b>Lauf</b></p> <p>F <sup>1)</sup>* = 9.00                  Z <sup>1)</sup> = 9.28</p> <p><b>Züge</b></p> <p>b = 3.14                  N = 6                  u = 360.00                  Q = 66.31 mm<sup>2</sup></p>	
	<p><b>Hülsenhals</b></p> <p>H1* = 9.92                  H2 <sup>1)</sup> = 9.92</p> <p><b>Geschoss</b></p> <p>G1 <sup>1)</sup> = 9.30                  G2 =                  F =                  L3+G <sup>1)</sup> = 83.01</p> <p><b>Drücke (Energien)</b>  <b>Mech. elektr. Wandler</b></p> <p>Pmax = 4150 bar                  PK = 4773 bar                  PE = 5188 bar                  M = 25.00                  EE = 6000 Joule</p> <p><b>Verschiedene Daten</b></p> <p>Fe <sup>1)</sup> = 0.10                  delta L =</p>	<p><b>Längen</b></p> <p>L1* = 55.75                  L2* = 58.17                  L3 <sup>1)</sup> = 66.30</p> <p><b>Stoßboden</b></p> <p>R =                  R1 = 12.00                  R2 =                  R3 =                  r =</p> <p><b>Pulverkammer</b></p> <p>E = 3.24                  P1 <sup>1)</sup> = 12.18                  P2* = 11.48</p> <p><b>Schulterkonus</b></p> <p>α <sup>1)</sup> = 35°05'06"                  S = 73.91                  r1 max = 0.50                  r2 = 0.50</p> <p><b>Hülsenhals</b></p> <p>H1* = 9.95                  H2 <sup>1)</sup> = 9.94</p> <p><b>Geschossübergang</b></p> <p>G1 <sup>1)</sup>* = 9.35                  G <sup>1)</sup>* = 17.01                  α1 = 89°02'13"                  h* = 0.30                  s =                  i <sup>1)</sup> = 0°36'                  w =</p> <p><b>Lauf</b></p> <p>F <sup>1)</sup>* = 9.00                  Z <sup>1)</sup> = 9.28</p> <p><b>Züge</b></p> <p>b = 3.14                  N = 6                  u = 360.00                  Q = 66.31 mm<sup>2</sup></p>	
Maßstab 1:1  Maße in << mm >> Maße und Toleranzen für Messläufe siehe Anhang CR 1.	Bemerkungen: 1) Kontrolle aus Sicherheitsgründen * Grundmaße		

<b>C.I.P.</b>	<b>9,3 RSM</b>		<b>TAB.</b>	<b>I</b>
	Ursprungsland: DE		Datum	11-05-25
			Revision	
	<b>PATRONE MAXI</b>		<b>PATRONENLAGER MINI</b>	
	<p><b>Längen</b></p> <p>L1 <sup>1)</sup> = 42.24 -0.20                  L2 <sup>1)</sup> = 44.88 -0.20                  L3 <sup>1)</sup> = 53.32                  L4 =                  L5 =                  L6 = 75.00</p> <p><b>Hülsenboden</b></p> <p>R = 1.37                  R1 = 13.59                  R3 =                  E = 3.36                  E1 = 12.19                  e min = 1.02                  δ = 45°                  f = 0.36                  β = 45°</p> <p><b>Pulverkammer</b></p> <p>P1 = 14.12                  P2 <sup>1)</sup>* = 13.67 -0.20</p> <p><b>Schulterkonus</b></p> <p>α * = 70°                  S * = 52.00                  r1 min = 0.80                  r2 = 2.54</p> <p><b>Hülsenhals</b></p> <p>H1 * = 9.98                  H2 <sup>1)</sup> = 9.98</p> <p><b>Geschoss</b></p> <p>G1 <sup>1)</sup> = 9.30                  G2 =                  F =                  L3+G <sup>1)</sup> = 59.66</p> <p><b>Drücke (Energien)</b></p> <p><b>Mech. elektr. Wandler</b></p> <p>Pmax = 4400 bar                  PK = 5060 bar                  PE = 5720 bar                  M = 25.00                  EE = 5250 Joule</p> <p><b>Verschiedene Daten</b></p> <p>Fe <sup>1)3)</sup> = 0.10                  delta L =</p>		<p><b>Längen</b></p> <p>L1 = 42.40                  L2 = 44.87                  L3 <sup>1)</sup> = 53.59</p> <p><b>Stoßboden</b></p> <p>R = 1.37                  R1 = 14.13                  R2 =                  R3 =                  r =</p> <p><b>Pulverkammer</b></p> <p>E = 3.36                  P1 <sup>1)</sup> = 14.25                  P2 * = 13.70</p> <p><b>Schulterkonus</b></p> <p>α <sup>1)</sup>* = 70°                  S * = 52.18                  r1 max = 1.27                  r2 = 3.05</p> <p><b>Hülsenhals</b></p> <p>H1 * = 10.24                  H2 <sup>1)</sup> = 10.24</p> <p><b>Geschossübergang</b></p> <p>G1 <sup>1)</sup>* = 9.35                  G <sup>1)</sup> = 6.34                  α1 = 90°                  h = 0.45                  s = 3.48                  i <sup>1)</sup>* = 3°30'                  w =</p> <p><b>Lauf</b></p> <p>F <sup>1)</sup>* = 9.00                  Z <sup>1)</sup> = 9.28</p> <p><b>Züge</b></p> <p>b = 4.60                  N = 6                  u = 406.40                  Q = 67.67 mm<sup>2</sup></p>	
Maßstab 1.01:1  Maße in << mm >> Maße und Toleranzen für Messläufe siehe Anhang CR1.		Bemerkungen: 1) Kontrolle aus Sicherheitsgründen 3) Verschlussabstand an Schulter * Grundmaße		

<b>C.I.P.</b>	<b>9,5 x 57 Mannl. Sch.</b>  Ursprungsland: AT	TAB.	I
		Datum	95-06-28
		Revision	02-05-15
	<b>PATRONE MAXI</b>	<b>PATRONE MINIMAL</b>	
	<p><b>Längen</b></p> <p>L1 <sup>1)</sup>* = 46.50 -0.20                  L2 <sup>1)</sup>* = 48.02 -0.20                  L3 <sup>1)</sup> = 57.00                  L4 =                  L5 =                  L6 = 75.00</p> <p><b>Hülsenboden</b></p> <p>R = 1.20                  R1 = 11.90                  R3 =                  E = 3.20                  E1 = 10.30                  e min = 1.00                  delta = 38°39'35"                  f = 0.30                  beta = 45°</p> <p><b>Pulverkammer</b></p> <p>P1 = 11.90                  P2 <sup>1)</sup>* = 11.40 -0.20</p> <p><b>Schulterkonus</b></p> <p>alpha = 42°06'01"                  S = 61.31                  r1 min = 0.50                  r2 = 0.50</p> <p><b>Hülsenhals</b></p> <p>H1* = 10.23                  H2 <sup>1)</sup> = 10.18</p> <p><b>Geschoss</b></p> <p>G1 <sup>1)</sup> = 9.55                  G2 =                  F =                  L3+G <sup>1)</sup> = 68.40</p> <p><b>Drücke (Energien)</b></p> <p><b>Mech. elektr. Wandler</b></p> <p>Pmax = 3050 bar                  PK = 3508 bar                  PE = 3810 bar                  M = 25.00                  EE = 6065 Joule</p> <p><b>Verschiedene Daten</b></p> <p>Fe <sup>1)</sup> = 0.15                  delta L =</p>	<p><b>Längen</b></p> <p>L1* = 46.46                  L2* = 47.96                  L3 <sup>1)</sup> = 57.30</p> <p><b>Stoßboden</b></p> <p>R = 1.20                  R1 = 11.95                  R2 =                  R3 =                  r =</p> <p><b>Pulverkammer</b></p> <p>E = 3.20                  P1 <sup>1)</sup> = 11.93                  P2* = 11.43</p> <p><b>Schulterkonus</b></p> <p>alpha <sup>1)</sup> = 41°56'48"                  S = 61.37                  r1 max = 0.50                  r2 = 0.50</p> <p><b>Hülsenhals</b></p> <p>H1* = 10.28                  H2 <sup>1)</sup> = 10.22</p> <p><b>Geschossübergang</b></p> <p>G1 <sup>1)</sup>* = 9.65                  G <sup>1)</sup>* = 11.40                  alpha1 = 180°                  h =                  s =                  i <sup>1)</sup> = 0°57'17"                  w =</p> <p><b>Lauf</b></p> <p>F <sup>1)</sup>* = 9.27                  Z <sup>1)</sup> = 9.62</p> <p><b>Züge</b></p> <p>b = 4.60                  N = 4                  u = 300.00                  Q = 70.85 mm<sup>2</sup></p>	
	<p>Maßstab 1:1</p> <p>Maße in &lt;&lt; mm &gt;&gt;                  Maße und Toleranzen für Messläufe                  siehe Anhang CR 1.</p>		
		<p>Bemerkungen: 1) Kontrolle aus Sicherheitsgründen                  * Grundmaße</p>	



<b>C.I.P.</b>	<b>9,5 x 66 SE v. H.</b>	<b>TAB. I</b>	
		<b>Datum</b>	<b>96-05-24</b>
		<b>Revision</b>	<b>02-05-15</b>
Ursprungsland: DE			
	<b>PATRONE MAXI</b>		
	<b>Längen</b> L1 <sup>1)</sup> * = 55.00 -0.20 L2 <sup>1)</sup> * = 57.00 -0.20 L3 <sup>1)</sup> = 66.00 L4 = L5 = L6 = 85.00  <b>Hülsenboden</b> R = 1.30 R1 = 13.00 R3 = E = 3.70 E1 = 11.50 e min = 1.00 delta = 40° f = 0.30 beta = 45°  <b>Pulverkammer</b> P1 = 13.85 P2 <sup>1)</sup> * = 13.70 -0.20  <b>Schulterkonus</b> alpha = 81°23'28" S = 62.97 r1 min = 0.50 r2 = 1.00  <b>Hülsenhals</b> H1* = 10.26 H2 <sup>1)</sup> = 10.26  <b>Geschoss</b> G1 <sup>1)</sup> = 9.55 G2 = F = L3+G <sup>1)</sup> = 74.92  <b>Drücke (Energien)</b> <b>Mech. elektr. Wandler</b> Pmax = 4400 bar PK = 5060 bar PE = 5500 bar M = 25.00 EE = 6080 Joule  <b>Verschiedene Daten</b> Fe <sup>1)</sup> = 0.10 delta L =		<b>PATRONE MIN</b>  <b>Längen</b> L1* = 54.99 L2* = 56.98 L3 <sup>1)</sup> = 66.30  <b>Stoßboden</b> R = 1.30 R1 = 13.05 R2 = R3 = r =  <b>Pulverkammer</b> E = 3.70 P1 <sup>1)</sup> = 13.88 P2* = 13.73  <b>Schulterkonus</b> alpha <sup>1)</sup> = 81°30'36" S = 62.96 r1 max = 0.50 r2 = 1.00  <b>Hülsenhals</b> H1* = 10.30 H2 <sup>1)</sup> = 10.29  <b>Geschossübergang</b> G1 <sup>1)</sup> * = 9.91 G <sup>1)</sup> * = 8.92 alpha1 = 90° h* = 0.19 s = i <sup>1)</sup> = 2°00'03" w =  <b>Lauf</b> F <sup>1)</sup> * = 9.30 Z <sup>1)</sup> = 9.55  <b>Züge</b> b = 2.92 N = 6 u = 305.00 Q = 70.16 mm <sup>2</sup>
Maßstab 1:1  Maße in << mm >> Maße und Toleranzen für Messläufe siehe Anhang CR 1.		Bemerkungen: 1) Kontrolle aus Sicherheitsgründen * Grundmaße	

<b>C.I.P.</b>	<b>10,3 CSP</b> Ursprungsland: CH	<b>TAB.</b>	<b>I</b>
		<b>Datum</b>	<b>16-05-18</b>
		<b>Revision</b>	
	<p><b>PATRONE MAXI</b></p> <p><b>Längen</b></p> <p>L1 <sup>1)</sup> = 42.27 -0.20                  L2 <sup>1)</sup> = 43.89 -0.20                  L3 <sup>1)</sup> = 52.50                  L4 =                  L5 =                  L6 = 72.70</p> <p><b>Hülsenboden</b></p> <p>R = 1.37                  R1 = 13.59                  R3 =                  E = 3.36                  E1 = 12.19                  e min = 1.02                  delta = 45°                  f = 0.36                  beta = 35°</p> <p><b>Pulverkammer</b></p> <p>P1 = 14.12                  P2 <sup>1)</sup>* = 13.67 -0.20</p> <p><b>Schulterkonus</b></p> <p>alpha * = 70°                  S * = 52.03                  r1 min = 1.27                  r2 = 1.27</p> <p><b>Hülsenhals</b></p> <p>H1 * = 11.40                  H2 <sup>1)</sup> = 11.34</p> <p><b>Geschoss</b></p> <p>G1 <sup>1)</sup> = 10.54                  G2 =                  F =                  L3+G <sup>1)</sup> = 59.95</p> <p><b>Drücke (Energien)</b></p> <p><b>Mech. elektr. Wandler</b></p> <p>Pmax = 4400 bar                  PK = 5060 bar                  PE = 5500 bar                  M = 25.00                  EE = 6200 Joule</p> <p><b>Verschiedene Daten</b></p> <p>Fe <sup>1)3)</sup> = 0.10                  delta L =</p>	<p><b>PATRONENLAGER MINI</b></p> <p><b>Längen</b></p> <p>L1 = 42.30                  L2 = 43.94                  L3 <sup>1)</sup> = 52.82</p> <p><b>Stoßboden</b></p> <p>R =                  R1 = 14.19                  R2 =                  R3 =                  r =</p> <p><b>Pulverkammer</b></p> <p>E = 3.35                  P1 <sup>1)</sup> = 14.15                  P2 * = 13.70</p> <p><b>Schulterkonus</b></p> <p>alpha <sup>1)</sup>* = 70°                  S * = 52.08                  r1 max = 1.27                  r2 = 1.27</p> <p><b>Hülsenhals</b></p> <p>H1 * = 11.40                  H2 <sup>1)</sup> = 11.40</p> <p><b>Geschossübergang</b></p> <p>G1 <sup>1)</sup>* = 10.62                  G <sup>1)</sup> = 7.45                  alpha1 = 90°                  h * = 0.39                  s =                  i <sup>1)</sup>* = 1°30'                  w =</p> <p><b>Lauf</b></p> <p>F <sup>1)</sup>* = 10.25                  Z <sup>1)</sup> = 10.49</p> <p><b>Züge</b></p> <p>b = 3.60                  N = 6                  u = 450.00                  Q = 85.16 mm<sup>2</sup></p>	
			<p>Maßstab 1.03:1</p> <p>Maße in &lt;&lt; mm &gt;&gt;                  Maße und Toleranzen für Messläufe                  siehe Anhang CR1.</p>

<b>C.I.P.</b>	<b>10,75 x 68</b> Ursprungsland: DE	<b>TAB.</b>	<b>I</b>
		<b>Datum</b>	<b>84-06-14</b>
		<b>Revision</b>	<b>02-05-15</b>
	<b>PATRONE MAXI</b>	<b>PATRONENLAGER MINI</b>	
	<p><b>Längen</b></p> <p>L1 <sup>1)</sup>* = 53.35 -0.20                  L2 <sup>1)</sup>* = 54.00 -0.20                  L3 <sup>1)</sup> = 68.00                  L4 =                  L5 = 68.50                  L6 = 81.00</p> <p><b>Hülsenboden</b></p> <p>R = 1.30                  R1 = 12.57                  R3 =                  E = 3.60                  E1 = 10.60                  e min = 1.00                  delta = 37°06'36"                  f = 0.30                  beta = 45°</p> <p><b>Pulverkammer</b></p> <p>P1 = 12.57                  P2 <sup>1)</sup>* = 12.20 -0.20</p> <p><b>Schulterkonus</b></p> <p>alpha = 55°54'58"                  S = 64.84                  r1 min = 0.50                  r2 = 0.50</p> <p><b>Hülsenhals</b></p> <p>H1 * = 11.51                  H2 <sup>1)</sup> = 11.51</p> <p><b>Geschoss</b></p> <p>G1 <sup>1)</sup> = 10.78                  G2 = 10.78                  F =                  L3+G <sup>1)</sup> = 98.00</p> <p><b>Drücke (Energien)</b></p> <p><b>Mech. elektr. Wandler</b></p> <p>Pmax = 3300 bar                  PK = 3795 bar                  PE = 4125 bar                  M = 25.00                  EE = 5040 Joule</p> <p><b>Verschiedene Daten</b></p> <p>Fe <sup>1)</sup> = 0.15                  delta L =</p>	<p><b>Längen</b></p> <p>L1 * = 53.32                  L2 * = 53.97                  L3 <sup>1)</sup> = 68.30</p> <p><b>Stoßboden</b></p> <p>R = 1.30                  R1 = 12.62                  R2 =                  R3 =                  r =</p> <p><b>Pulverkammer</b></p> <p>E = 3.60                  P1 <sup>1)</sup> = 12.60                  P2 * = 12.23</p> <p><b>Schulterkonus</b></p> <p>alpha <sup>1)</sup> = 55°54'58"                  S = 64.84                  r1 max = 0.50                  r2 = 0.50</p> <p><b>Hülsenhals</b></p> <p>H1 * = 11.54                  H2 <sup>1)</sup> = 11.52</p> <p><b>Geschossübergang</b></p> <p>G1 <sup>1)</sup>* = 10.82                  G <sup>1)</sup>* = 30.00                  alpha1 = 180°                  h =                  s =                  i <sup>1)</sup> = 0°21'12"                  w =</p> <p><b>Lauf</b></p> <p>F <sup>1)</sup>* = 10.45                  Z <sup>1)</sup> = 10.75</p> <p><b>Züge</b></p> <p>b = 3.60                  N = 6                  u = 420.00                  Q = 89.07 mm<sup>2</sup></p>	
Maßstab 1:1.5  Maße in << mm >> Maße und Toleranzen für Messläufe siehe Anhang CR 1.		Bemerkungen: 1) Kontrolle aus Sicherheitsgründen * Grundmaße	

<b>C.I.P.</b>	<b>12,7 x 70 (500 Schüler)</b>	TAB. <b>I</b>
		Datum <b>98-01-27</b>
		Revision <b>02-05-15</b>
Ursprungsland: DE		
	<b>PATRONE MAXI</b>	<b>PATRONENLAGER MINI</b>
	<p><b>Längen</b></p> <p>L1 <sup>1)</sup>* = 59.00 -0.20                  L2 <sup>1)</sup>* = 61.30 -0.20                  L3 <sup>1)</sup> = 70.00                  L4 =                  L5 =                  L6 = 88.00</p> <p><b>Hülsenboden</b></p> <p>R = 1.30                  R1 = 14.65                  R3 =                  E = 3.61                  E1 = 13.10                  e min = 1.00                  delta = 45°                  f = 0.30                  beta = 45°</p> <p><b>Pulverkammer</b></p> <p>P1 = 15.73                  P2 <sup>1)</sup>* = 15.32 -0.20</p> <p><b>Schulterkonus</b></p> <p>alpha = 39°54'22"                  S = 80.10                  r1 min = 3.00                  r2 = 4.00</p> <p><b>Hülsenhals</b></p> <p>H1* = 13.65                  H2 <sup>1)</sup> = 13.65</p> <p><b>Geschoss</b></p> <p>G1 <sup>1)</sup> = 12.96                  G2 =                  F =                  L3+G <sup>1)</sup> = 77.22</p> <p><b>Drücke (Energien)</b></p> <p><b>Mech. elektr. Wandler</b></p> <p>Pmax = 3300 bar                  PK = 3795 bar                  PE = 4125 bar                  M = 25.00                  EE = 9240 Joule</p> <p><b>Verschiedene Daten</b></p> <p>Fe <sup>1)</sup> = 0.15                  delta L =</p>	<p><b>Längen</b></p> <p>L1* = 58.96                  L2* = 61.23                  L3 <sup>1)</sup> = 70.50</p> <p><b>Stoßboden</b></p> <p>R = 1.30                  R1 = 14.70                  R2 =                  R3 =                  r =</p> <p><b>Pulverkammer</b></p> <p>E = 3.61                  P1 <sup>1)</sup> = 15.76                  P2* = 15.35</p> <p><b>Schulterkonus</b></p> <p>alpha <sup>1)</sup> = 39°56'45"                  S = 80.08                  r1 max = 1.00                  r2 = 4.00</p> <p><b>Hülsenhals</b></p> <p>H1* = 13.70                  H2 <sup>1)</sup> = 13.68</p> <p><b>Geschossübergang</b></p> <p>G1 <sup>1)</sup>* = 13.05                  G <sup>1)</sup>* = 7.22                  alpha1 = 90°                  h* = 0.31                  s =                  i <sup>1)</sup> = 1°51'54"                  w =</p> <p><b>Lauf</b></p> <p>F <sup>1)</sup>* = 12.60                  Z <sup>1)</sup> = 12.94</p> <p><b>Züge</b></p> <p>b = 3.58                  N = 8                  u = 450.00                  Q = 129.62 mm<sup>2</sup></p>
Maßstab 1:1.5		
Maße in << mm >> Maße und Toleranzen für Messläufe siehe Anhang CR 1.		Bemerkungen: 1) Kontrolle aus Sicherheitsgründen * Grundmaße

<b>C.I.P.</b>	<b>17 Libra</b>		<b>TAB.</b>	<b>I</b>
	Ursprungsland: CZ		Datum	01-01-22
			Revision	02-05-15
	<b>PATRONE MAXI</b>		<b>PATRONENLAGER MINI</b>	
	<p><b>Längen</b></p> <p>L1 <sup>1)</sup>* = 21.78 -0.20                      L2 <sup>1)</sup>* = 25.01 -0.20                      L3 <sup>1)</sup> = 30.10                      L4 =                      L5 =                      L6 = 41.00</p> <p><b>Hülsenboden</b></p> <p>R = 1.24                      R1 = 7.65                      R3 =                      E = 3.50                      E1 = 6.40                      e min = 0.75                      delta = 20°                      f = 0.30                      beta = 45°</p> <p><b>Pulverkammer</b></p> <p>P1 = 7.56                      P2 <sup>1)</sup>* = 6.88 -0.20</p> <p><b>Schulterkonus</b></p> <p>alpha = 34°04'51"                      S = 33.00                      r1 min = 0.64                      r2 = 2.54</p> <p><b>Hülsenhals</b></p> <p>H1* = 4.90                      H2 <sup>1)</sup> = 4.90</p> <p><b>Geschoss</b></p> <p>G1 <sup>1)</sup> = 4.28                      G2 =                      F =                      L3+G <sup>1)</sup> = 32.87</p> <p><b>Drücke (Energien)</b>  <b>Mech. elektr. Wandler</b></p> <p>Pmax = 4300 bar                      PK = 4945 bar                      PE = 5375 bar                      M = 17.50                      EE = 1500 Joule</p> <p><b>Verschiedene Daten</b></p> <p>Fe <sup>1)</sup> = 0.10                      delta L = 0.25</p>		<p><b>Längen</b></p> <p>L1* = 21.35                      L2* = 24.63                      L3 <sup>1)</sup> = 30.20</p> <p><b>Stoßboden</b></p> <p>R =                      R1 = 7.67                      R2 =                      R3 =                      r =</p> <p><b>Pulverkammer</b></p> <p>E = 2.77                      P1 <sup>1)</sup> = 7.62                      P2* = 7.00</p> <p><b>Schulterkonus</b></p> <p>alpha <sup>1)</sup> = 34°13'48"                      S = 32.72                      r1 max = 0.64                      r2 = 3.18</p> <p><b>Hülsenhals</b></p> <p>H1* = 4.98                      H2 <sup>1)</sup> = 4.90</p> <p><b>Geschossübergang</b></p> <p>G1 <sup>1)</sup>* = 4.40                      G <sup>1)</sup>* = 2.77                      alpha1 = 90°                      h* = 0.25                      s =                      i <sup>1)</sup> = 1°28'39"                      w =</p> <p><b>Lauf</b></p> <p>F <sup>1)</sup>* = 4.27                      Z <sup>1)</sup> = 4.40</p> <p><b>Züge</b></p> <p>b = 1.57                      N = 6                      u = 229.00                      Q = 14.95 mm<sup>2</sup></p>	
Maßstab 1.5:1				
Maße in << mm >> Maße und Toleranzen für Messläufe siehe Anhang CR 1.		Bemerkungen: 1) Kontrolle aus Sicherheitsgründen * Grundmaße		

<b>C.I.P.</b>	<b>17 Rem.</b>		<b>TAB.</b>	<b>I</b>
	Ursprungsland: US		<b>Datum</b>	<b>84-06-14</b>
			<b>Revision</b>	<b>02-05-15</b>
	<b>PATRONE MAXI</b>		<b>PATRONENLAGER MINI</b>	
	<p><b>Längen</b></p> <p>L1 <sup>1)</sup> = 34.31 -0.20</p> <p>L2 <sup>1)</sup> = 39.01 -0.20</p> <p>L3 <sup>1)</sup> = 45.62</p> <p>L4 =</p> <p>L5 =</p> <p>L6 = 54.61</p> <p><b>Hülsenboden</b></p> <p>R = 1.14</p> <p>R1 = 9.60</p> <p>R3 =</p> <p>E = 3.13</p> <p>E1 = 8.43</p> <p>e min = 0.76</p> <p>delta = 25°</p> <p>f = 0.45</p> <p>beta = 35°</p> <p><b>Pulverkammer</b></p> <p>P1 = 9.58</p> <p>P2 <sup>1)*</sup> = 9.04 -0.20</p> <p><b>Schulterkonus</b></p> <p>alpha * = 46°</p> <p>S * = 44.96</p> <p>r1 min = 0.64</p> <p>r2 = 2.54</p> <p><b>Hülsenhals</b></p> <p>H1 * = 5.05</p> <p>H2 <sup>1)</sup> = 5.05</p> <p><b>Geschoss</b></p> <p>G1 <sup>1)</sup> = 4.38</p> <p>G2 =</p> <p>F =</p> <p>L3+G <sup>1)</sup> = 47.74</p> <p><b>Drücke (Energien)</b></p> <p><b>Mech. elektr. Wandler</b></p> <p>Pmax = 4250 bar</p> <p>PK = 4888 bar</p> <p>PE = 5310 bar</p> <p>M = 25.00</p> <p>EE = 1290 Joule</p> <p><b>Verschiedene Daten</b></p> <p>Fe <sup>1)</sup> = 0.10</p> <p>delta L = 0.07</p>		<p><b>Längen</b></p> <p>L1 = 34.22</p> <p>L2 = 38.87</p> <p>L3 <sup>1)</sup> = 45.92</p> <p><b>Stoßboden</b></p> <p>R =</p> <p>R1 = 9.66</p> <p>R2 =</p> <p>R3 =</p> <p>r =</p> <p><b>Pulverkammer</b></p> <p>E = 3.13</p> <p>P1 <sup>1)</sup> = 9.61</p> <p>P2 * = 9.06</p> <p><b>Schulterkonus</b></p> <p>alpha <sup>1)*</sup> = 46°</p> <p>S * = 44.89</p> <p>r1 max = 0.64</p> <p>r2 = 3.18</p> <p><b>Hülsenhals</b></p> <p>H1 * = 5.11</p> <p>H2 <sup>1)</sup> = 5.08</p> <p><b>Geschossübergang</b></p> <p>G1 <sup>1)*</sup> = 4.37</p> <p>G <sup>1)</sup> = 2.12</p> <p>alpha 1 * = 90°</p> <p>h = 0.36</p> <p>s = 0.99</p> <p>i <sup>1)*</sup> = 2°32'41"</p> <p>w =</p> <p><b>Lauf</b></p> <p>F <sup>1)*</sup> = 4.27</p> <p>Z <sup>1)</sup> = 4.37</p> <p><b>Züge</b></p> <p>b = 1.57</p> <p>N = 6</p> <p>u = 229.00</p> <p>Q = 14.80 mm<sup>2</sup></p>	
Maßstab 1:1				
<p>Maße in &lt;&lt; mm &gt;&gt;</p> <p>Maße und Toleranzen für Messläufe siehe Anhang CR 1.</p>			<p>Bemerkungen: 1) Kontrolle aus Sicherheitsgründen * Grundmaße</p>	

<b>C.I.P.</b>	<b>17 Rem. Fireball</b> Ursprungsland: US	<b>TAB.</b>	<b>I</b>
		<b>Datum</b>	<b>08-04-15</b>
		<b>Revision</b>	<b>11-05-25</b>
	<p align="center"><b>PATRONE MAXI</b></p> <p><b>Längen</b></p> <p>L1 <sup>1)</sup> = 27.05 -0.20                  L2 <sup>1)</sup> = 30.60 -0.20                  L3 <sup>1)</sup> = 35.81                  L4 =                  L5 =                  L6 = 46.48</p> <p><b>Hülsenboden</b></p> <p>R = 1.14                  R1 = 9.60                  R3 =                  E = 3.12                  E1 = 8.43                  e min = 0.76                  delta = 25°                  f = 0.45                  beta = 35°</p> <p><b>Pulverkammer</b></p> <p>P1 = 9.57                  P2 <sup>1)</sup>* = 9.28 -0.20</p> <p><b>Schulterkonus</b></p> <p>alpha * = 60°                  S * = 35.08                  r1 min = 0.64                  r2 = 2.54</p> <p><b>Hülsenhals</b></p> <p>H1 * = 5.18                  H2 <sup>1)</sup> = 5.18</p> <p><b>Geschoss</b></p> <p>G1 <sup>1)</sup> = 4.38                  G2 =                  F =                  L3+G <sup>1)</sup> = 40.29</p> <p><b>Drücke (Energien)</b></p> <p><b>Mech. elektr. Wandler</b></p> <p>Pmax = 3800 bar                  PK = 4370 bar                  PE = 4750 bar                  M = 17.50                  EE = 980 Joule</p> <p><b>Verschiedene Daten</b></p> <p>Fe <sup>1)</sup> = 0.15                  delta L = 0.11</p>	<p align="center"><b>PATRONENLAGER MINI</b></p> <p><b>Längen</b></p> <p>L1 = 26.92                  L2 = 30.45                  L3 <sup>1)</sup> = 36.07</p> <p><b>Stoßboden</b></p> <p>R =                  R1 = 9.63                  R2 =                  R3 =                  r =</p> <p><b>Pulverkammer</b></p> <p>E = 3.12                  P1 <sup>1)</sup> = 9.60                  P2 * = 9.31</p> <p><b>Schulterkonus</b></p> <p>alpha <sup>1)</sup>* = 60°                  S * = 34.98                  r1 max = 0.64                  r2 = 3.18</p> <p><b>Hülsenhals</b></p> <p>H1 * = 5.23                  H2 <sup>1)</sup> = 5.21</p> <p><b>Geschossübergang</b></p> <p>G1 <sup>1)</sup>* = 4.39                  G <sup>1)</sup> = 4.48                  alpha1 * = 90°                  h = 0.41                  s = 1.04                  i <sup>1)</sup>* = 1°                  w =</p> <p><b>Lauf</b></p> <p>F <sup>1)</sup>* = 4.27                  Z <sup>1)</sup> = 4.37</p> <p><b>Züge</b></p> <p>b = 1.57                  N = 6                  u = 228.60                  Q = 14.80 mm<sup>2</sup></p>	
			<p>Maßstab 1.35:1</p> <p align="center">Maße in &lt;&lt; mm &gt;&gt; Maße und Toleranzen für Messläufe siehe Anhang CR 1.</p>

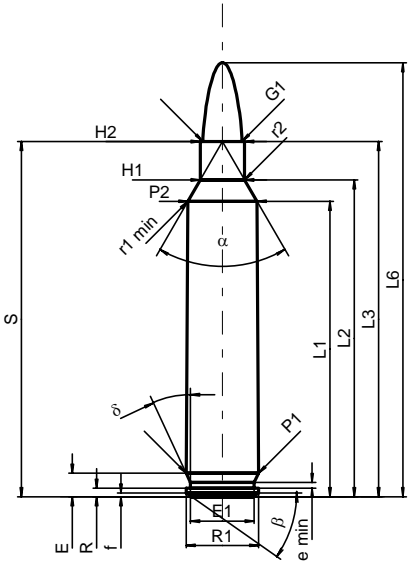
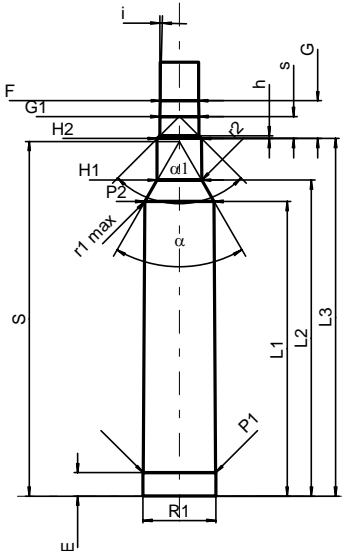
<b>C.I.P.</b>	<b>204 Ruger</b>		<b>TAB. I</b>
	Ursprungsland: US		<b>Datum 06-05-16</b>
			<b>Revision</b>
	<b>PATRONE MAXI</b>		<b>PATRONENLAGER MINI</b>
	<p><b>Längen</b></p> <p>L1<sup>1)</sup> = 39.08 -0.20                  L2<sup>1)</sup> = 41.91 -0.20                  L3<sup>1)</sup> = 46.99                  L4 =                  L5 =                  L6 = 57.40</p> <p><b>Hülsenboden</b></p> <p>R = 1.14                  R1 = 9.60                  R3 =                  E = 3.11                  E1 = 8.43                  e min = 0.76                  delta = 25°                  f = 0.48                  beta = 35°</p> <p><b>Pulverkammer</b></p> <p>P1 = 9.56                  P2<sup>1)*</sup> = 9.14 -0.20</p> <p><b>Schulterkonus</b></p> <p>alpha* = 60°                  S* = 46.99                  r1 min = 0.64                  r2 = 2.54</p> <p><b>Hülsenhals</b></p> <p>H1* = 5.87                  H2<sup>1)</sup> = 5.87</p> <p><b>Geschoss</b></p> <p>G1<sup>1)*</sup> = 5.19                  G2 =                  F =                  L3+G<sup>1)</sup> = 51.98</p> <p><b>Drücke (Energien)</b>  <b>Mech. elektr. Wandler</b></p> <p>Pmax = 4050 bar                  PK = 4658 bar                  PE = 5063 bar                  M = 25.00                  EE = 1940 Joule</p> <p><b>Verschiedene Daten</b></p> <p>Fe = 0.10                  delta L =</p>		<p><b>Längen</b></p> <p>L1 = 38.97                  L2 = 41.79                  L3<sup>1)</sup> = 47.31</p> <p><b>Stoßboden</b></p> <p>R =                  R1 = 9.63                  R2 =                  R3 =                  r =</p> <p><b>Pulverkammer</b></p> <p>E = 3.11                  P1<sup>1)</sup> = 9.59                  P2* = 9.16</p> <p><b>Schulterkonus</b></p> <p>alpha<sup>1)*</sup> = 60°                  S* = 46.92                  r1 max = 0.64                  r2 = 3.18</p> <p><b>Hülsenhals</b></p> <p>H1* = 5.91                  H2<sup>1)</sup> = 5.89</p> <p><b>Geschossübergang</b></p> <p>G1<sup>1)*</sup> = 5.19                  G = 4.99                  alpha1 = 90°                  h = 0.35                  s* = 2.89                  i<sup>1)*</sup> = 1°30'                  w =</p> <p><b>Lauf</b></p> <p>F<sup>1)*</sup> = 5.08                  Z<sup>1)</sup> = 5.18</p> <p><b>Züge</b></p> <p>b = 1.37                  N = 6                  u = 305.00                  Q = 20.68 mm<sup>2</sup></p>
	<p>Maßstab 1:1</p> <p>Maße in &lt;&lt; mm &gt;&gt;                  Maße und Toleranzen für Messläufe                  siehe Anhang CR 1.</p>		
		<p>Bemerkungen: 1) Kontrolle aus Sicherheitsgründen                  * Grundmaße</p>	



C.I.P.	215	TAB.	I
		Datum	92-02-27
		Revision	11-05-25
Ursprungsland: DE			
	<b>PATRONE MAXI</b>		
	<p><b>Längen</b></p> <p>L1 <sup>1)</sup>* = 30.00 -0.20                  L2 <sup>1)</sup>* = 33.97 -0.20                  L3 <sup>1)</sup> = 39.60                  L4 =                  L5 =                  L6 = 58.00</p> <p><b>Hülsenboden</b></p> <p>R = 1.50                  R1 = 10.00                  R3 =                  E = 3.20                  E1 = 8.60                  e min = 1.00                  delta = 45°                  f = 0.50                  beta = 45°</p> <p><b>Pulverkammer</b></p> <p>P1 = 10.00                  P2 <sup>1)</sup>* = 9.25 -0.20</p> <p><b>Schulterkonus</b></p> <p>alpha = 40°30'36"                  S = 42.53                  r1 min =                  r2 =</p> <p><b>Hülsenhals</b></p> <p>H1 * = 6.32                  H2 <sup>1)</sup> = 6.32</p> <p><b>Geschoss</b></p> <p>G1 <sup>1)</sup> = 5.64                  G2 =                  F =                  L3+G <sup>1)</sup> = 44.72</p> <p><b>Drücke (Energien)</b></p> <p><b>Mech. elektr. Wandler</b></p> <p>Pmax = 3800 bar                  PK = 4370 bar                  PE = 4750 bar                  M = 17.50                  EE = 1505 Joule</p> <p><b>Verschiedene Daten</b></p> <p>Fe <sup>1)3)</sup> = 0.15                  delta L =</p>		
	<b>PATRONENLAGER MINI</b>		
	<p><b>Längen</b></p> <p>L1 * = 29.93                  L2 * = 33.78                  L3 <sup>1)</sup> = 40.13</p> <p><b>Stoßboden</b></p> <p>R = 1.50                  R1 = 10.05                  R2 =                  R3 =                  r =</p> <p><b>Pulverkammer</b></p> <p>E = 3.83                  P1 <sup>1)</sup> = 10.00                  P2 * = 9.30</p> <p><b>Schulterkonus</b></p> <p>alpha <sup>1)</sup> = 40°29'27"                  S = 42.54                  r1 max =                  r2 =</p> <p><b>Hülsenhals</b></p> <p>H1 * = 6.46                  H2 <sup>1)</sup> = 6.33</p> <p><b>Geschossübergang</b></p> <p>G1 <sup>1)</sup>* = 6.33                  G <sup>1)</sup>* = 5.12                  alpha l = 180°                  h =                  s =                  i <sup>1)</sup> = 5°11'21"                  w =</p> <p><b>Lauf</b></p> <p>F <sup>1)</sup>* = 5.40                  Z <sup>1)</sup> = 5.60</p> <p><b>Züge</b></p> <p>b = 1.81                  N = 6                  u = 214.00                  Q = 24.01 mm<sup>2</sup></p>		
Maßstab 1.31:1  Maße in << mm >> Maße und Toleranzen für Messläufe siehe Anhang CR 1.		Bemerkungen: 1) Kontrolle aus Sicherheitsgründen 3) Verschlussabstand an Schulter * Grundmaße	

<b>C.I.P.</b>	<b>22 PPC-USA</b>		<b>TAB.</b>	<b>I</b>
	Ursprungsland: FI		Datum	89-04-18
			Revision	02-05-15
	<b>PATRONE MAXI</b>		<b>PATRONENLAGER MINI</b>	
	<p><b>Längen</b></p> <p>L1 <sup>1)</sup>* = 27.30 -0.20</p> <p>L2 <sup>1)</sup>* = 31.28 -0.20</p> <p>L3 <sup>1)</sup> = 38.48</p> <p>L4 =</p> <p>L5 =</p> <p>L6 = 55.70</p> <p><b>Hülsenboden</b></p> <p>R = 1.50</p> <p>R1 = 11.30</p> <p>R3 =</p> <p>E = 3.50</p> <p>E1 = 9.60</p> <p>e min = 1.10</p> <p>δ = 42°40'48"</p> <p>f = 0.40</p> <p>β = 45°</p> <p><b>Pulverkammer</b></p> <p>P1 = 11.26</p> <p>P2 <sup>1)</sup>* = 10.95 -0.20</p> <p><b>Schulterkonus</b></p> <p>α = 60°02'47"</p> <p>S = 36.77</p> <p>r1 min = 1.00</p> <p>r2 = 3.00</p> <p><b>Hülsenhals</b></p> <p>H1 * = 6.35</p> <p>H2 <sup>1)</sup> = 6.35</p> <p><b>Geschoss</b></p> <p>G1 <sup>1)</sup> = 5.70</p> <p>G2 =</p> <p>F =</p> <p>L3+G <sup>1)</sup> = 43.96</p> <p><b>Drücke (Energien)</b></p> <p><b>Mech. elektr. Wandler</b></p> <p>Pmax = 4050 bar</p> <p>PK = 4658 bar</p> <p>PE = 5060 bar</p> <p>M = 17.50</p> <p>EE = 1935 Joule</p> <p><b>Verschiedene Daten</b></p> <p>Fe <sup>1)</sup> = 0.10</p> <p>delta L =</p>		<p><b>Längen</b></p> <p>L1 * = 27.27</p> <p>L2 * = 31.25</p> <p>L3 <sup>1)</sup> = 38.74</p> <p><b>Stoßboden</b></p> <p>R = 1.50</p> <p>R1 = 11.32</p> <p>R2 =</p> <p>R3 =</p> <p>r =</p> <p><b>Pulverkammer</b></p> <p>E = 3.50</p> <p>P1 <sup>1)</sup> = 11.28</p> <p>P2 * = 10.98</p> <p><b>Schulterkonus</b></p> <p>α <sup>1)</sup> = 59°56'18"</p> <p>S = 36.79</p> <p>r1 max = 0.50</p> <p>r2 = 3.00</p> <p><b>Hülsenhals</b></p> <p>H1 * = 6.39</p> <p>H2 <sup>1)</sup> = 6.38</p> <p><b>Geschossübergang</b></p> <p>G1 <sup>1)</sup>* = 5.72</p> <p>G <sup>1)</sup>* = 5.48</p> <p>α1 = 90°</p> <p>h = 0.33</p> <p>s * = 1.85</p> <p>i <sup>1)</sup> = 1°30'</p> <p>w =</p> <p><b>Lauf</b></p> <p>F <sup>1)</sup>* = 5.53</p> <p>Z <sup>1)</sup> = 5.66</p> <p><b>Züge</b></p> <p>b = 2.04</p> <p>N = 6</p> <p>u = 355.00</p> <p>Q = 24.83 mm<sup>2</sup></p>	
Maßstab 1:1				
<p>Maße in &lt;&lt; mm &gt;&gt;</p> <p>Maße und Toleranzen für Messläufe siehe Anhang CR 1.</p>		<p>Bemerkungen: 1) Kontrolle aus Sicherheitsgründen * Grundmaße</p>		

<b>C.I.P.</b>	<b>22-250 Rem</b>		<b>TAB.</b>	<b>I</b>
	Ursprungsland: US		<b>Datum</b>	<b>84-06-14</b>
			<b>Revision</b>	<b>02-05-15</b>
	<b>PATRONE MAXI</b>		<b>PATRONENLAGER MINI</b>	
	<p><b>Längen</b></p> <p>L1<sup>1)</sup> = 38.48 -0.20                  L2<sup>1)</sup> = 42.26 -0.20                  L3<sup>1)</sup> = 48.46                  L4 =                  L5 =                  L6 = 59.69</p> <p><b>Hülsenboden</b></p> <p>R = 1.24                  R1 = 12.01                  R3 =                  E = 3.22                  E1 = 10.39                  e min = 0.84                  delta = 34°                  f = 0.38                  beta = 35°</p> <p><b>Pulverkammer</b></p> <p>P1 = 11.93                  P2<sup>1)*</sup> = 10.52 -0.20</p> <p><b>Schulterkonus</b></p> <p>alpha* = 56°                  S* = 48.37                  r1 min = 2.54                  r2 = 2.54</p> <p><b>Hülsenhals</b></p> <p>H1* = 6.50                  H2<sup>1)</sup> = 6.45</p> <p><b>Geschoss</b></p> <p>G1<sup>1)</sup> = 5.70                  G2 =                  F =                  L3+G<sup>1)</sup> = 52.39</p> <p><b>Drücke (Energien)</b></p> <p><b>Mech. elektr. Wandler</b></p> <p>Pmax = 4050 bar                  PK = 4658 bar                  PE = 5060 bar                  M = 25.00                  EE = 2370 Joule</p> <p><b>Verschiedene Daten</b></p> <p>Fe<sup>1)</sup> = 0.10                  delta L = 0.08</p>		<p><b>Längen</b></p> <p>L1 = 38.36                  L2 = 42.15                  L3<sup>1)</sup> = 48.87</p> <p><b>Stoßboden</b></p> <p>R =                  R1 = 12.09                  R2 =                  R3 =                  r =</p> <p><b>Pulverkammer</b></p> <p>E = 3.22                  P1<sup>1)</sup> = 11.96                  P2* = 10.56</p> <p><b>Schulterkonus</b></p> <p>alpha<sup>1)*</sup> = 56°                  S* = 48.29                  r1 max = 0.64                  r2 = 3.18</p> <p><b>Hülsenhals</b></p> <p>H1* = 6.53                  H2<sup>1)</sup> = 6.48</p> <p><b>Geschossübergang</b></p> <p>G1<sup>1)*</sup> = 5.70                  G<sup>1)</sup> = 3.93                  alpha1 = 90°                  h = 0.39                  s* = 1.93                  i<sup>1)*</sup> = 2°                  w =</p> <p><b>Lauf</b></p> <p>F<sup>1)*</sup> = 5.56                  Z<sup>1)</sup> = 5.69</p> <p><b>Züge</b></p> <p>b = 2.03                  N = 6                  u = 356.00                  Q = 25.09 mm<sup>2</sup></p>	
Maßstab 1:1				
Maße in << mm >> Maße und Toleranzen für Messläufe siehe Anhang CR 1.		Bemerkungen: 1) Kontrolle aus Sicherheitsgründen * Grundmaße		

<b>C.I.P.</b>	<b>220 Swift</b>		<b>TAB.</b>	<b>I</b>
	Ursprungsland: US		Datum	84-06-14
			Revision	08-09-23
	<b>PATRONE MAXI</b>		<b>PATRONENLAGER MINI</b>	
	<p><b>Längen</b></p> <p>L1 <sup>1)</sup> = 43.76 -0.20                  L2 <sup>1)</sup> = 48.41 -0.20                  L3 <sup>1)</sup> = 56.01                  L4 =                  L5 =                  L6 = 68.07</p> <p><b>Hülsenboden</b></p> <p>R = 1.24                  R1 = 12.01                  R3 =                  E = 2.89                  E1 = 10.82                  e min = 0.64                  delta = 15°                  f = 0.38                  beta = 35°</p> <p><b>Pulverkammer</b></p> <p>P1 = 11.36                  P2 <sup>1)</sup>* = 10.21 -0.20</p> <p><b>Schulterkonus</b></p> <p>alpha * = 42°                  S * = 57.06                  r1 min = 0.76                  r2 = 2.54</p> <p><b>Hülsenhals</b></p> <p>H1 * = 6.64                  H2 <sup>1)</sup> = 6.60</p> <p><b>Geschoss</b></p> <p>G1 <sup>1)</sup> = 5.70                  G2 =                  F =                  L3+G <sup>1)</sup> = 60.22</p> <p><b>Drücke (Energien)</b></p> <p><b>Mech. elektr. Wandler</b></p> <p>Pmax = 4300 bar                  PK = 4945 bar                  PE = 5375 bar                  M = 25.00                  EE = 2380 Joule</p> <p><b>Verschiedene Daten</b></p> <p>Fe <sup>1)3)</sup> = 0.10                  delta L = 0.10</p>		<p><b>Längen</b></p> <p>L1 = 43.62                  L2 = 48.27                  L3 <sup>1)</sup> = 56.16</p> <p><b>Stoßboden</b></p> <p>R = 1.35                  R1 = 12.27                  R2 =                  R3 =                  r =</p> <p><b>Pulverkammer</b></p> <p>E = 1.35                  P1 <sup>1)</sup> = 11.43                  P2 * = 10.24</p> <p><b>Schulterkonus</b></p> <p>alpha <sup>1)</sup>* = 42°                  S * = 56.96                  r1 max = 0.76                  r2 = 3.81</p> <p><b>Hülsenhals</b></p> <p>H1 * = 6.67                  H2 <sup>1)</sup> = 6.63</p> <p><b>Geschossübergang</b></p> <p>G1 <sup>1)</sup>* = 5.74                  G <sup>1)</sup> = 4.21                  alpha1 = 60°                  h * = 0.77                  s =                  i <sup>1)</sup>* = 1°30'                  w =</p> <p><b>Lauf</b></p> <p>F <sup>1)</sup>* = 5.56                  Z <sup>1)</sup> = 5.69</p> <p><b>Züge</b></p> <p>b = 1.88                  N = 6                  u = 356.00                  Q = 25.03 mm<sup>2</sup></p>	
Maßstab 1.11:1  Maße in << mm >> Maße und Toleranzen für Messläufe siehe Anhang CR 1.		Bemerkungen: 1) Kontrolle aus Sicherheitsgründen 3) Verschlussabstand an Schulter * Grundmaße		

<b>C.I.P.</b>	<b>222 Rem.</b>	TAB.	I
		Datum	84-06-14
		Revision	08-09-13
Ursprungsland: US			
	<b>PATRONE MAXI</b>	<b>PATRONENLAGER MINI</b>	
	<p><b>Längen</b></p> <p>L1 <sup>1)</sup> = 32.13 -0.20</p> <p>L2 <sup>1)</sup> = 35.24 -0.20</p> <p>L3 <sup>1)</sup> = 43.18</p> <p>L4 =</p> <p>L5 =</p> <p>L6 = 54.10</p> <p><b>Hülsenboden</b></p> <p>R = 1.14</p> <p>R1 = 9.60</p> <p>R3 =</p> <p>E = 3.01</p> <p>E1 = 8.43</p> <p>e min = 0.64</p> <p>delta = 25°</p> <p>f = 0.45</p> <p>beta = 35°</p> <p><b>Pulverkammer</b></p> <p>P1 = 9.58</p> <p>P2 <sup>1)</sup>* = 9.07 -0.20</p> <p><b>Schulterkonus</b></p> <p>alpha * = 46°</p> <p>S * = 42.81</p> <p>r1 min = 0.64</p> <p>r2 = 2.54</p> <p><b>Hülsenhals</b></p> <p>H1 * = 6.43</p> <p>H2 <sup>1)</sup> = 6.43</p> <p><b>Geschoss</b></p> <p>G1 <sup>1)</sup> = 5.70</p> <p>G2 =</p> <p>F =</p> <p>L3+G <sup>1)</sup> = 45.37</p> <p><b>Drücke (Energien)</b></p> <p><b>Mech. elektr. Wandler</b></p> <p>Pmax = 3700 bar</p> <p>PK = 4255 bar</p> <p>PE = 4625 bar</p> <p>M = 25.00</p> <p>EE = 1810 Joule</p> <p><b>Verschiedene Daten</b></p> <p>Fe <sup>1)3)</sup> = 0.15</p> <p>delta L = 0.08</p>	<p><b>Längen</b></p> <p>L1 = 32.01</p> <p>L2 = 35.10</p> <p>L3 <sup>1)</sup> = 43.48</p> <p><b>Stoßboden</b></p> <p>R =</p> <p>R1 = 9.66</p> <p>R2 =</p> <p>R3 =</p> <p>r =</p> <p><b>Pulverkammer</b></p> <p>E = 3.01</p> <p>P1 <sup>1)</sup> = 9.61</p> <p>P2 * = 9.10</p> <p><b>Schulterkonus</b></p> <p>alpha <sup>1)</sup>* = 46°</p> <p>S * = 42.74</p> <p>r1 max = 0.64</p> <p>r2 = 3.18</p> <p><b>Hülsenhals</b></p> <p>H1 * = 6.48</p> <p>H2 <sup>1)</sup> = 6.45</p> <p><b>Geschossübergang</b></p> <p>G1 <sup>1)</sup>* = 5.69</p> <p>G <sup>1)</sup> = 2.191</p> <p>alpha l = 90°</p> <p>h = 0.38</p> <p>s * = 1.02</p> <p>i <sup>1)</sup>* = 3°10'36"</p> <p>w =</p> <p><b>Lauf</b></p> <p>F <sup>1)</sup>* = 5.56</p> <p>Z <sup>1)</sup> = 5.69</p> <p><b>Züge</b></p> <p>b = 2.03</p> <p>N = 6</p> <p>u = 356.00</p> <p>Q = 25.09 mm<sup>2</sup></p>	
Maßstab 1.35:1			
<p>Maße in &lt;&lt; mm &gt;&gt;</p> <p>Maße und Toleranzen für Messläufe siehe Anhang CR 1.</p>		<p>Bemerkungen: 1) Kontrolle aus Sicherheitsgründen</p> <p>3) Verschlussabstand an Schulter</p> <p>* Grundmaße</p>	

<b>C.I.P.</b>	<b>222 Rem. Mag.</b> Ursprungsland: US	TAB. <b>I</b>
		Datum <b>84-06-14</b>
		Revision <b>02.05 15</b>
	<b>PATRONE MAXI</b>	<b>PATRONENLAGER MINI</b>
	<p><b>Längen</b></p> <p>L1<sup>1)</sup> = 37.18 -0.20                  L2<sup>1)</sup> = 40.29 -0.20                  L3<sup>1)</sup> = 46.99                  L4 =                  L5 =                  L6 = 57.91</p> <p><b>Hülsenboden</b></p> <p>R = 1.14                  R1 = 9.60                  R3 =                  E = 3.11                  E1 = 8.43                  e min = 0.76                  delta = 25°                  f = 0.45                  beta = 35°</p> <p><b>Pulverkammer</b></p> <p>P1 = 9.56                  P2<sup>1)*</sup> = 9.07 -0.20</p> <p><b>Schulterkonus</b></p> <p>alpha* = 46°                  S* = 47.86                  r1 min = 0.64                  r2 = 2.54</p> <p><b>Hülsenhals</b></p> <p>H1* = 6.43                  H2<sup>1)</sup> = 6.43</p> <p><b>Geschoss</b></p> <p>G1<sup>1)</sup> = 5.70                  G2 =                  F =                  L3+G<sup>1)</sup> = 49.18</p> <p><b>Drücke (Energien)</b> <b>Mech. elektr. Wandler</b></p> <p>Pmax = 4050 bar                  PK = 4658 bar                  PE = 5060 bar                  M = 25.00                  EE = 1820 Joule</p> <p><b>Verschiedene Daten</b></p> <p>Fe<sup>1)</sup> = 0.10                  delta L = 0.09</p>	<p><b>Längen</b></p> <p>L1 = 37.07                  L2 = 40.15                  L3<sup>1)</sup> = 47.29</p> <p><b>Stoßboden</b></p> <p>R =                  R1 = 9.63                  R2 =                  R3 =                  r =</p> <p><b>Pulverkammer</b></p> <p>E = 3.11                  P1<sup>1)</sup> = 9.59                  P2* = 9.09</p> <p><b>Schulterkonus</b></p> <p>alpha<sup>1)*</sup> = 46°                  S* = 47.78                  r1 max = 0.64                  r2 = 3.18</p> <p><b>Hülsenhals</b></p> <p>H1* = 6.48                  H2<sup>1)</sup> = 6.45</p> <p><b>Geschossübergang</b></p> <p>G1<sup>1)*</sup> = 5.69                  G<sup>1)</sup> = 2.19                  alpha1 = 90°                  h = 0.38                  s* = 1.02                  i<sup>1)*</sup> = 3°10'36"                  w =</p> <p><b>Lauf</b></p> <p>F<sup>1)*</sup> = 5.56                  Z<sup>1)</sup> = 5.69</p> <p><b>Züge</b></p> <p>b = 2.03                  N = 6                  u = 356.00                  Q = 25.09 mm<sup>2</sup></p>
Maßstab 1:1		
Maße in << mm >> Maße und Toleranzen für Messläufe siehe Anhang CR 1.	Bemerkungen: 1) Kontrolle aus Sicherheitsgründen * Grundmaße	

<b>C.I.P.</b>	<b>223 Rem.</b>		<b>TAB.</b>	<b>I</b>
	Ursprungsland: US		<b>Datum</b>	<b>84-06-14</b>
			<b>Revision</b>	<b>02-05-15</b>
	<b>PATRONE MAXI</b>		<b>PATRONENLAGER MINI</b>	
	<p><b>Längen</b></p> <p>L1 <sup>1)</sup> = 36.52 -0.20</p> <p>L2 <sup>1)</sup> = 39.55 -0.20</p> <p>L3 <sup>1)</sup> = 44.70</p> <p>L4 =</p> <p>L5 =</p> <p>L6 = 57.40</p> <p><b>Hülsenboden</b></p> <p>R = 1.14</p> <p>R1 = 9.60</p> <p>R3 =</p> <p>E = 3.13</p> <p>E1 = 8.43</p> <p>e min = 0.76</p> <p>delta = 25°</p> <p>f = 0.45</p> <p>beta = 35°</p> <p><b>Pulverkammer</b></p> <p>P1 = 9.58</p> <p>P2 <sup>1)</sup>* = 9.00 -0.20</p> <p><b>Schulterkonus</b></p> <p>alpha* = 46°</p> <p>S* = 47.12</p> <p>r1 min = 0.64</p> <p>r2 = 2.54</p> <p><b>Hülsenhals</b></p> <p>H1* = 6.43</p> <p>H2 <sup>1)</sup> = 6.43</p> <p><b>Geschoss</b></p> <p>G1 <sup>1)</sup> = 5.70</p> <p>G2 =</p> <p>F =</p> <p>L3+G <sup>1)</sup> = 46.88</p> <p><b>Drücke (Energien)</b></p> <p><b>Mech. elektr. Wandler</b></p> <p>Pmax = 4300 bar</p> <p>PK = 4945 bar</p> <p>PE = 5375 bar</p> <p>M = 25.00</p> <p>EE = 1825 Joule</p> <p><b>Verschiedene Daten</b></p> <p>Fe <sup>1)</sup> = 0.10</p> <p>delta L = 0.07</p>		<p><b>Längen</b></p> <p>L1 = 36.42</p> <p>L2 = 39.42</p> <p>L3 <sup>1)</sup> = 45.01</p> <p><b>Stoßboden</b></p> <p>R =</p> <p>R1 = 9.66</p> <p>R2 =</p> <p>R3 =</p> <p>r =</p> <p><b>Pulverkammer</b></p> <p>E = 3.13</p> <p>P1 <sup>1)</sup> = 9.61</p> <p>P2* = 9.02</p> <p><b>Schulterkonus</b></p> <p>alpha <sup>1)</sup>* = 46°</p> <p>S* = 47.05</p> <p>r1 max = 0.64</p> <p>r2 = 3.18</p> <p><b>Hülsenhals</b></p> <p>H1* = 6.48</p> <p>H2 <sup>1)</sup> = 6.45</p> <p><b>Geschossübergang</b></p> <p>G1 <sup>1)</sup>* = 5.69</p> <p>G <sup>1)</sup> = 2.18</p> <p>alpha1 = 90°</p> <p>h = 0.38</p> <p>s* = 1.01</p> <p>i <sup>1)</sup>* = 3°10'36"</p> <p>w =</p> <p><b>Lauf</b></p> <p>F <sup>1)</sup>* = 5.56</p> <p>Z <sup>1)</sup> = 5.69</p> <p><b>Züge</b></p> <p>b = 1.88</p> <p>N = 6</p> <p>u = 305.00</p> <p>Q = 25.03 mm<sup>2</sup></p>	
Maßstab 1:1				
<p>Maße in &lt;&lt; mm &gt;&gt;</p> <p>Maße und Toleranzen für Messläufe siehe Anhang CR 1.</p>		<p>Bemerkungen: 1) Kontrolle aus Sicherheitsgründen * Grundmaße</p>		

<b>C.I.P.</b>	<b>223 Win. Super Short Mag.</b>	TAB.	I
		Datum	04-05-18
		Revision	08-09-23
Ursprungsland: US			
	<b>PATRONE MAXI</b>	<b>PATRONENLAGER MINI</b>	
	<p><b>Längen</b></p> <p>L1 <sup>1)</sup> = 29.20 -0.20                  L2 <sup>1)</sup> = 35.71 -0.20                  L3 <sup>1)</sup> = 42.42                  L4 =                  L5 =                  L6 = 59.94</p> <p><b>Hülsenboden</b></p> <p>R = 1.37                  R1 = 13.59                  R3 =                  E = 3.35                  E1 = 12.19                  e min = 1.02                  delta = 45°                  f = 0.36                  beta = 35°</p> <p><b>Pulverkammer</b></p> <p>P1 = 14.12                  P2 <sup>1)</sup>* = 13.83 -0.20</p> <p><b>Schulterkonus</b></p> <p>alpha * = 56°                  S * = 42.21                  r1 min = 1.27                  r2 = 3.30</p> <p><b>Hülsenhals</b></p> <p>H1 * = 6.91                  H2 <sup>1)</sup> = 6.91</p> <p><b>Geschoss</b></p> <p>G1 <sup>1)</sup> = 5.70                  G2 =                  F =                  L3+G <sup>1)</sup> = 45.73</p> <p><b>Drücke (Energien)</b></p> <p><b>Mech. elektr. Wandler</b></p> <p>Pmax = 4400 bar                  PK = 5060 bar                  PE = 5500 bar                  M = 25.00                  EE = 2600 Joule</p> <p><b>Verschiedene Daten</b></p> <p>Fe <sup>3)</sup> = 0.10                  delta L = 0.08</p>	<p><b>Längen</b></p> <p>L1 = 29.12                  L2 = 35.58                  L3 <sup>1)</sup> = 42.67</p> <p><b>Stoßboden</b></p> <p>R =                  R1 = 14.20                  R2 =                  R3 =                  r =</p> <p><b>Pulverkammer</b></p> <p>E = 3.35                  P1 <sup>1)</sup> = 14.15                  P2 * = 13.86</p> <p><b>Schulterkonus</b></p> <p>alpha <sup>1)</sup>* = 56°                  S * = 42.15                  r1 max = 1.27                  r2 = 4.06</p> <p><b>Hülsenhals</b></p> <p>H1 * = 6.99                  H2 <sup>1)</sup> = 6.93</p> <p><b>Geschossübergang</b></p> <p>G1 <sup>1)</sup>* = 5.75                  G <sup>1)</sup> = 3.31                  alpha 1 * = 90°                  h = 0.59                  s =                  i <sup>1)</sup>* = 2°                  w =</p> <p><b>Lauf</b></p> <p>F <sup>1)</sup>* = 5.56                  Z <sup>1)</sup> = 5.69</p> <p><b>Züge</b></p> <p>b = 2.03                  N = 6                  u = 254.00                  Q = 25.09 mm<sup>2</sup></p>	
<p>Maßstab 1.03:1</p> <p style="text-align: center;">Maße in &lt;&lt; mm &gt;&gt; Maße und Toleranzen für Messläufe siehe Anhang CR 1.</p>		<p>Bemerkungen: 1) Kontrolle aus Sicherheitsgründen 3) Verschlussabstand an Schulter * Grundmaße</p>	





<b>C.I.P.</b>	<b>243 Win. Super Short Mag.</b>	TAB.	I
		Datum	03-11-07
		Revision	08-09-23
Ursprungsland: US			
	<b>PATRONE MAXI</b>	<b>PATRONENLAGER MINI</b>	
	<p><b>Längen</b></p> <p>L1 <sup>1)</sup> = 29.21 -0.20                  L2 <sup>1)</sup> = 35.35 -0.20                  L3 <sup>1)</sup> = 42.42                  L4 =                  L5 =                  L6 = 59.94</p> <p><b>Hülsenboden</b></p> <p>R = 1.37                  R1 = 13.49                  R3 =                  E = 3.35                  E1 = 12.19                  e min = 1.02                  delta = 45°                  f = 0.36                  beta = 35°</p> <p><b>Pulverkammer</b></p> <p>P1 = 14.12                  P2 <sup>1)</sup>* = 13.82 -0.20</p> <p><b>Schulterkonus</b></p> <p>alpha * = 56°                  S * = 42.21                  r1 min = 1.27                  r2 = 3.30</p> <p><b>Hülsenhals</b></p> <p>H1 * = 7.29                  H2 <sup>1)</sup> = 7.29</p> <p><b>Geschoss</b></p> <p>G1 <sup>1)</sup> = 6.17                  G2 =                  F =                  L3+G <sup>1)</sup> = 47.16</p> <p><b>Drücke (Energien)</b></p> <p><b>Mech. elektr. Wandler</b></p> <p>Pmax = 4400 bar                  PK = 5060 bar                  PE = 5500 bar                  M = 25.00                  EE = 3150 Joule</p> <p><b>Verschiedene Daten</b></p> <p>Fe <sup>3)</sup> = 0.10                  delta L = 0.08</p>	<p><b>Längen</b></p> <p>L1 = 29.11                  L2 = 35.25                  L3 <sup>1)</sup> = 42.67</p> <p><b>Stoßboden</b></p> <p>R =                  R1 = 14.20                  R2 =                  R3 =                  r =</p> <p><b>Pulverkammer</b></p> <p>E = 3.35                  P1 <sup>1)</sup> = 14.15                  P2 * = 13.87</p> <p><b>Schulterkonus</b></p> <p>alpha <sup>1)</sup>* = 56°                  S * = 42.15                  r1 max = 1.27                  r2 = 4.06</p> <p><b>Hülsenhals</b></p> <p>H1 * = 7.34                  H2 <sup>1)</sup> = 7.32</p> <p><b>Geschossübergang</b></p> <p>G1 <sup>1)</sup>* = 6.24                  G <sup>1)</sup> = 4.74                  alpha 1 * = 90°                  h = 0.54                  s =                  i <sup>1)</sup>* = 1°30'                  w =</p> <p><b>Lauf</b></p> <p>F <sup>1)</sup>* = 6.02                  Z <sup>1)</sup> = 6.17</p> <p><b>Züge</b></p> <p>b = 2.54                  N = 4                  u = 254.00                  Q = 29.25 mm<sup>2</sup></p>	
Maßstab 1.03:1			
Maße in << mm >> Maße und Toleranzen für Messläufe siehe Anhang CR 1.		Bemerkungen: 1) Kontrolle aus Sicherheitsgründen 3) Verschlussabstand an Schulter * Grundmaße	

<b>C.I.P.</b>	<b>25 Rem.</b>		<b>TAB.</b>	<b>I</b>
	Ursprungsland: US		<b>Datum</b>	<b>84-06-14</b>
			<b>Revision</b>	<b>02-05-15</b>
	<b>PATRONE MAXI</b>		<b>PATRONENLAGER MINI</b>	
	<p><b>Längen</b></p> <p>L1<sup>1)</sup> = 38.05 -0.20                  L2<sup>1)</sup> = 41.42 -0.20                  L3<sup>1)</sup> = 52.07                  L4 =                  L5 =                  L6 = 64.14</p> <p><b>Hülsenboden</b></p> <p>R = 1.24                  R1 = 10.72                  R3 =                  E = 3.20                  E1 = 9.09                  e min = 0.84                  delta = 36°                  f = 0.33                  beta = 35°</p> <p><b>Pulverkammer</b></p> <p>P1 = 10.72                  P2<sup>1)*</sup> = 10.19 -0.20</p> <p><b>Schulterkonus</b></p> <p>alpha* = 46°                  S* = 50.05                  r1 min = 0.64                  r2 = 2.54</p> <p><b>Hülsenhals</b></p> <p>H1* = 7.33                  H2<sup>1)</sup> = 7.26</p> <p><b>Geschoss</b></p> <p>G1<sup>1)</sup> = 6.58                  G2 =                  F =                  L3+G<sup>1)</sup> = 56.07</p> <p><b>Drücke (Energien)</b></p> <p><b>Mech. elektr. Wandler</b></p> <p>Pmax = 2450 bar                  PK = 2817 bar                  PE = 3063 bar                  M = 25.00                  EE = 1995 Joule</p> <p><b>Verschiedene Daten</b></p> <p>Fe<sup>1)</sup> = 0.15                  delta L =</p>		<p><b>Längen</b></p> <p>L1 = 38.01                  L2 = 41.40                  L3<sup>1)</sup> = 52.20</p> <p><b>Stoßboden</b></p> <p>R =                  R1 = 10.78                  R2 =                  R3 =                  r =</p> <p><b>Pulverkammer</b></p> <p>E = 3.20                  P1<sup>1)</sup> = 10.75                  P2* = 10.22</p> <p><b>Schulterkonus</b></p> <p>alpha<sup>1)*</sup> = 46°                  S* = 50.05                  r1 max = 0.64                  r2 = 2.54</p> <p><b>Hülsenhals</b></p> <p>H1* = 7.34                  H2<sup>1)</sup> = 7.26</p> <p><b>Geschossübergang</b></p> <p>G1<sup>1)*</sup> = 6.58                  G<sup>1)</sup> = 4.00                  alpha1* = 60°                  h = 0.59                  s =                  i<sup>1)*</sup> = 1°55'59"                  w =</p> <p><b>Lauf</b></p> <p>F<sup>1)*</sup> = 6.35                  Z<sup>1)</sup> = 6.50</p> <p><b>Züge</b></p> <p>b = 2.41                  N = 6                  u = 254.00                  Q = 32.78 mm<sup>2</sup></p>	
Maßstab 1:1				
Maße in << mm >> Maße und Toleranzen für Messläufe siehe Anhang CR 1.		Bemerkungen: 1) Kontrolle aus Sicherheitsgründen * Grundmaße		

<b>C.I.P.</b>	<b>25 Win. Super Short Mag.</b>	TAB.	I
		Datum	06-05-16
		Revision	11-05-25
Ursprungsland: US			
	<b>PATRONE MAXI</b>		<b>PATRONENLAGER MINI</b>
	<p><b>Längen</b></p> <p>L1 <sup>1)</sup> = 29.40 -0.20                  L2 <sup>1)</sup> = 34.79 -0.20                  L3 <sup>1)</sup> = 42.42                  L4 =                  L5 =                  L6 = 59.94</p> <p><b>Hülsenboden</b></p> <p>R = 1.37                  R1 = 13.59                  R3 =                  E = 3.36                  E1 = 12.19                  e min = 1.02                  delta = 45°                  f = 0.35                  beta = 35°</p> <p><b>Pulverkammer</b></p> <p>P1 = 14.12                  P2 <sup>1)</sup>* = 13.83 -0.20</p> <p><b>Schulterkonus</b></p> <p>alpha * = 60°                  S * = 41.36                  r1 min = 1.27                  r2 = 3.30</p> <p><b>Hülsenhals</b></p> <p>H1 * = 7.60                  H2 <sup>1)</sup> = 7.60</p> <p><b>Geschoss</b></p> <p>G1 <sup>1)</sup>* = 6.54                  G2 =                  F =                  L3+G <sup>1)</sup> = 51.76</p> <p><b>Drücke (Energien)</b></p> <p><b>Mech. elektr. Wandler</b></p> <p>Pmax = 4400 bar                  PK = 5060 bar                  PE = 5500 bar                  M = 17.50                  EE = 3500 Joule</p> <p><b>Verschiedene Daten</b></p> <p>Fe <sup>1)3)</sup> = 0.10                  delta L = 0.08</p>		<p><b>Längen</b></p> <p>L1 = 29.29                  L2 = 34.67                  L3 <sup>1)</sup> = 42.68</p> <p><b>Stoßboden</b></p> <p>R =                  R1 = 14.19                  R2 =                  R3 =                  r =</p> <p><b>Pulverkammer</b></p> <p>E = 3.36                  P1 <sup>1)</sup> = 14.15                  P2 * = 13.86</p> <p><b>Schulterkonus</b></p> <p>alpha <sup>1)</sup>* = 60°                  S * = 41.30                  r1 max = 1.27                  r2 = 3.81</p> <p><b>Hülsenhals</b></p> <p>H1 * = 7.65                  H2 <sup>1)</sup> = 7.62</p> <p><b>Geschossübergang</b></p> <p>G1 <sup>1)</sup>* = 6.63                  G = 9.34                  alpha l = 90°                  h = 0.50                  s * = 4.67                  i <sup>1)</sup> = 1°43'                  w =</p> <p><b>Lauf</b></p> <p>F <sup>1)</sup>* = 6.35                  Z <sup>1)</sup> = 6.53</p> <p><b>Züge</b></p> <p>b = 2.44                  N = 6                  u = 254.00                  Q = 33.02 mm<sup>2</sup></p>
	<p>Maßstab 1.0:1</p> <p style="text-align: center;">Maße in &lt;&lt; mm &gt;&gt; Maße und Toleranzen für Messläufe siehe Anhang CR 1.</p>		<p>Bemerkungen: 1) Kontrolle aus Sicherheitsgründen                  3) Verschlussabstand an Schulter                  * Grundmaße</p>

<b>C.I.P.</b>	<b>25-06 Rem.</b>	<b>TAB.</b>	<b>I</b>
		<b>Datum</b>	<b>84-06-14</b>
		<b>Revision</b>	<b>08-09-23</b>
Ursprungsland: US			
	<b>PATRONE MAXI</b>		<b>PATRONENLAGER MINI</b>
	<p><b>Längen</b></p> <p>L1 <sup>1)</sup> = 49.48 -0.20</p> <p>L2 <sup>1)</sup> = 55.52 -0.20</p> <p>L3 <sup>1)</sup> = 63.35</p> <p>L4 =</p> <p>L5 =</p> <p>L6 = 82.55</p> <p><b>Hülsenboden</b></p> <p>R = 1.24</p> <p>R1 = 12.01</p> <p>R3 =</p> <p>E = 3.16</p> <p>E1 = 10.39</p> <p>e min = 0.84</p> <p>δ = 36°</p> <p>f = 0.38</p> <p>β = 35°</p> <p><b>Pulverkammer</b></p> <p>P1 = 11.96</p> <p>P2 <sup>1)</sup>* = 11.20 -0.20</p> <p><b>Schulterkonus</b></p> <p>α * = 35°</p> <p>S * = 67.24</p> <p>r1 min = 1.27</p> <p>r2 = 2.54</p> <p><b>Hülsenhals</b></p> <p>H1 * = 7.39</p> <p>H2 <sup>1)</sup> = 7.37</p> <p><b>Geschoss</b></p> <p>G1 <sup>1)</sup> = 6.54</p> <p>G2 =</p> <p>F =</p> <p>L3+G <sup>1)</sup> = 68.42</p> <p><b>Drücke (Energien)</b></p> <p><b>Mech. elektr. Wandler</b></p> <p>Pmax = 4400 bar</p> <p>PK = 5060 bar</p> <p>PE = 5500 bar</p> <p>M = 25.00</p> <p>EE = 3340 Joule</p> <p><b>Verschiedene Daten</b></p> <p>Fe <sup>1)3)</sup> = 0.10</p> <p>delta L = 0.15</p>		<p><b>Längen</b></p> <p>L1 = 49.27</p> <p>L2 = 55.42</p> <p>L3 <sup>1)</sup> = 63.55</p> <p><b>Stoßboden</b></p> <p>R =</p> <p>R1 = 12.04</p> <p>R2 =</p> <p>R3 =</p> <p>r =</p> <p><b>Pulverkammer</b></p> <p>E = 3.16</p> <p>P1 <sup>1)</sup> = 11.99</p> <p>P2 * = 11.24</p> <p><b>Schulterkonus</b></p> <p>α <sup>1)</sup>* = 34°30'</p> <p>S * = 67.37</p> <p>r1 max = 1.27</p> <p>r2 = 3.05</p> <p><b>Hülsenhals</b></p> <p>H1 * = 7.42</p> <p>H2 <sup>1)</sup> = 7.39</p> <p><b>Geschossübergang</b></p> <p>G1 <sup>1)</sup>* = 6.54</p> <p>G <sup>1)</sup> = 5.07</p> <p>α1 * = 71°25'48"</p> <p>h = 0.59</p> <p>s = 3.26</p> <p>i <sup>1)</sup>* = 3°</p> <p>w =</p> <p><b>Lauf</b></p> <p>F <sup>1)</sup>* = 6.35</p> <p>Z <sup>1)</sup> = 6.53</p> <p><b>Züge</b></p> <p>b = 2.44</p> <p>N = 6</p> <p>u = 254.00</p> <p>Q = 33.02 mm<sup>2</sup></p>
<p>Maßstab 1.0:1</p> <p>Maße in &lt;&lt; mm &gt;&gt;</p> <p>Maße und Toleranzen für Messläufe siehe Anhang CR 1.</p>		<p>Bemerkungen: 1) Kontrolle aus Sicherheitsgründen 3) Verschlussabstand an Schulter * Grundmaße</p>	

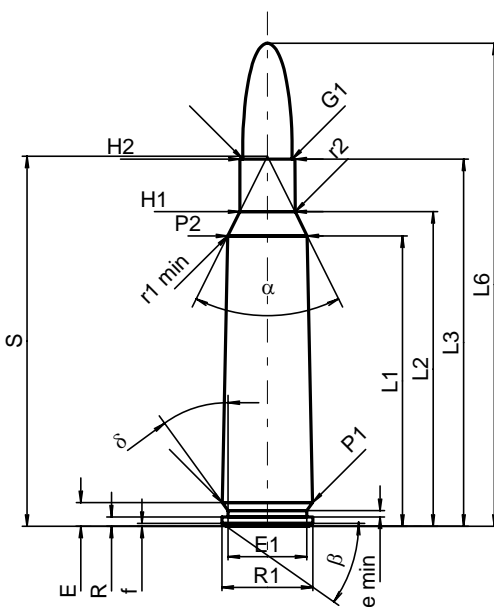
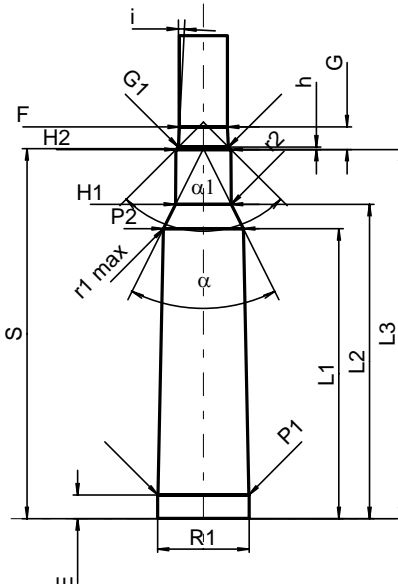
<b>C.I.P.</b>	<b>250 Savage</b>		<b>TAB. I</b>
	Ursprungsland: US		<b>Datum 84-06-14</b>
			<b>Revision 02-05-15</b>
	<b>PATRONE MAXI</b>		<b>PATRONENLAGER MINI</b>
	<p><b>Längen</b></p> <p>L1<sup>1)</sup> = 38.40 -0.20                  L2<sup>1)</sup> = 41.60 -0.20                  L3<sup>1)</sup> = 48.56                  L4 =                  L5 =                  L6 = 63.88</p> <p><b>Hülsenboden</b></p> <p>R = 1.24                  R1 = 12.01                  R3 =                  E = 3.14                  E1 = 10.39                  e min = 0.84                  delta = 36°                  f = 0.38                  beta = 35°</p> <p><b>Pulverkammer</b></p> <p>P1 = 11.93                  P2<sup>1)*</sup> = 10.52 -0.20</p> <p><b>Schulterkonus</b></p> <p>alpha* = 53°                  S* = 48.95                  r1 min = 2.54                  r2 = 2.54</p> <p><b>Hülsenhals</b></p> <p>H1* = 7.33                  H2<sup>1)</sup> = 7.25</p> <p><b>Geschoss</b></p> <p>G1<sup>1)</sup> = 6.55                  G2 =                  F =                  L3+G<sup>1)</sup> = 51.55</p> <p><b>Drücke (Energien)</b></p> <p><b>Mech. elektr. Wandler</b></p> <p>Pmax = 3650 bar                  PK = 4198 bar                  PE = 4560 bar                  M = 25.00                  EE = 2900 Joule</p> <p><b>Verschiedene Daten</b></p> <p>Fe<sup>1)</sup> = 0.15                  delta L =</p>		<p><b>Längen</b></p> <p>L1 = 38.36                  L2 = 41.58                  L3<sup>1)</sup> = 48.82</p> <p><b>Stoßboden</b></p> <p>R =                  R1 = 12.14                  R2 =                  R3 =                  r =</p> <p><b>Pulverkammer</b></p> <p>E = 3.14                  P1<sup>1)</sup> = 12.01                  P2* = 10.56</p> <p><b>Schulterkonus</b></p> <p>alpha<sup>1)*</sup> = 53°                  S* = 48.95                  r1 max = 2.54                  r2 = 2.54</p> <p><b>Hülsenhals</b></p> <p>H1* = 7.35                  H2<sup>1)</sup> = 7.26</p> <p><b>Geschossübergang</b></p> <p>G1<sup>1)*</sup> = 6.63                  G<sup>1)</sup> = 2.99                  alpha1* = 90°                  h = 0.32                  s =                  i<sup>1)*</sup> = 3°                  w =</p> <p><b>Lauf</b></p> <p>F<sup>1)*</sup> = 6.35                  Z<sup>1)</sup> = 6.53</p> <p><b>Züge</b></p> <p>b = 2.24                  N = 6                  u = 356.00                  Q = 32.90 mm<sup>2</sup></p>
			
Maßstab 1:1			
Maße in << mm >> Maße und Toleranzen für Messläufe siehe Anhang CR 1.	Bemerkungen: 1) Kontrolle aus Sicherheitsgründen * Grundmaße		

<b>C.I.P.</b>	<b>255 GS</b>		<b>TAB.</b>	<b>I</b>
	Ursprungsland: IT		<b>Datum</b>	<b>10-05-26</b>
			<b>Revision</b>	
	<b>PATRONE MAXI</b>		<b>PATRONENLAGER MINI</b>	
	<p><b>Längen</b></p> <p>L1 <sup>1)</sup> = 44.06 -0.20                      L2 <sup>1)</sup> = 47.06 -0.20                      L3 <sup>1)</sup> = 55.00                      L4 =                      L5 =                      L6 = 72.50</p> <p><b>Hülsenboden</b></p> <p>R = 1.50                      R1 = 12.20                      R3 =                      E = 3.25                      E1 = 10.50                      e min = 0.90                      delta = 45°                      f = 0.50                      beta = 45°</p> <p><b>Pulverkammer</b></p> <p>P1 = 12.20                      P2 <sup>1)</sup>* = 11.58 -0.20</p> <p><b>Schulterkonus</b></p> <p>alpha * = 70°                      S * = 52.33                      r1 min = 0.76                      r2 = 3.18</p> <p><b>Hülsenhals</b></p> <p>H1 * = 7.38                      H2 <sup>1)</sup> = 7.33</p> <p><b>Geschoss</b></p> <p>G1 <sup>1)</sup> = 6.54                      G2 =                      F =                      L3+G <sup>1)</sup> = 64.34</p> <p><b>Drücke (Energien)</b></p> <p><b>Mech. elektr. Wandler</b></p> <p>Pmax = 4400 bar                      PK = 5060 bar                      PE = 5500 bar                      M = 25.00                      EE = 3700 Joule</p> <p><b>Verschiedene Daten</b></p> <p>Fe <sup>1)3)</sup> = 0.10                      delta L =</p>		<p><b>Längen</b></p> <p>L1 = 44.02                      L2 = 47.05                      L3 <sup>1)</sup> = 55.10</p> <p><b>Stoßboden</b></p> <p>R = 1.50                      R1 = 12.23                      R2 =                      R3 =                      r = 0.40</p> <p><b>Pulverkammer</b></p> <p>E = 3.20                      P1 <sup>1)</sup> = 12.23                      P2 * = 11.64</p> <p><b>Schulterkonus</b></p> <p>alpha <sup>1)</sup>* = 70°                      S * = 52.34                      r1 max = 0.76                      r2 = 3.18</p> <p><b>Hülsenhals</b></p> <p>H1 * = 7.40                      H2 <sup>1)</sup> = 7.35</p> <p><b>Geschossübergang</b></p> <p>G1 <sup>1)</sup>* = 6.63                      G <sup>1)</sup> = 9.34                      alpha l = 90°                      h = 0.36                      s * = 4.67                      i <sup>1)</sup>* = 1°43'2"                      w =</p> <p><b>Lauf</b></p> <p>F <sup>1)</sup>* = 6.35                      Z <sup>1)</sup> = 6.53</p> <p><b>Züge</b></p> <p>b = 2.44                      N = 6                      u = 254.00                      Q = 33.02 mm<sup>2</sup></p>	
	<p>Maßstab 1.06:1</p> <p>Maße in &lt;&lt; mm &gt;&gt;                      Maße und Toleranzen für Messläufe                      siehe Anhang CR 1.</p>			
		<p>Bemerkungen: 1) Kontrolle aus Sicherheitsgründen                      3) Verschlussabstand an Schulter                      * Grundmaße</p>		

<b>C.I.P.</b>	<b>256 Mag. Gibbs</b>		<b>TAB.</b>	<b>I</b>
	Ursprungsland: GB		<b>Datum</b>	<b>84-06-14</b>
			<b>Revision</b>	<b>02-05-15</b>
	<b>PATRONE MAXI</b>		<b>PATRONENLAGER MINI</b>	
	<p><b>Längen</b></p> <p>L1 <sup>1)</sup>* = 44.83 -0.20                  L2 <sup>1)</sup>* = 49.20 -0.20                  L3 <sup>1)</sup> = 55.25                  L4 =                  L5 =                  L6 = 77.47</p> <p><b>Hülsenboden</b></p> <p>R = 1.02                  R1 = 12.09                  R3 =                  E = 3.18                  E1 = 10.41                  e min = 1.02                  delta = 35°03'36"                  f =                  beta =</p> <p><b>Pulverkammer</b></p> <p>P1 = 12.01                  P2 <sup>1)</sup>* = 10.82 -0.20</p> <p><b>Schulterkonus</b></p> <p>alpha = 40°13'07"                  S = 59.61                  r1 min = 7.11                  r2 = 5.08</p> <p><b>Hülsenhals</b></p> <p>H1* = 7.62                  H2 <sup>1)</sup> = 7.52</p> <p><b>Geschoss</b></p> <p>G1 <sup>1)</sup> = 6.73                  G2 =                  F =                  L3+G <sup>1)</sup> = 60.23</p> <p><b>Drücke (Energien)</b></p> <p><b>Mech. elektr. Wandler</b></p> <p>Pmax = 3400 bar                  PK = 3910 bar                  PE = 4250 bar                  M = 25.00                  EE = 2645 Joule</p> <p><b>Verschiedene Daten</b></p> <p>Fe <sup>1)</sup> = 0.15                  delta L =</p>		<p><b>Längen</b></p> <p>L1* = 44.78                  L2* = 49.20                  L3 <sup>1)</sup> = 55.55</p> <p><b>Stoßboden</b></p> <p>R = 1.02                  R1 = 12.14                  R2 =                  R3 =                  r =</p> <p><b>Pulverkammer</b></p> <p>E = 3.18                  P1 <sup>1)</sup> = 12.04                  P2* = 10.87</p> <p><b>Schulterkonus</b></p> <p>alpha <sup>1)</sup> = 40°01'43"                  S = 59.70                  r1 max =                  r2 =</p> <p><b>Hülsenhals</b></p> <p>H1* = 7.65                  H2 <sup>1)</sup> = 7.54</p> <p><b>Geschossübergang</b></p> <p>G1 <sup>1)</sup>* = 6.74                  G <sup>1)</sup>* = 4.98                  alpha1 = 90°                  h* = 0.40                  s =                  i <sup>1)</sup> = 1°30'03"                  w =</p> <p><b>Lauf</b></p> <p>F <sup>1)</sup>* = 6.50                  Z <sup>1)</sup> = 6.72</p> <p><b>Züge</b></p> <p>b =                  N =                  u =                  Q = 33.18 mm<sup>2</sup></p>	
Maßstab 1:1				
Maße in << mm >> Maße und Toleranzen für Messläufe siehe Anhang CR 1.		Bemerkungen: 1) Kontrolle aus Sicherheitsgründen * Grundmaße		



<b>C.I.P.</b>	<b>257 Roberts</b>		<b>TAB.</b>	<b>I</b>
	Ursprungsland: US		<b>Datum</b>	<b>84-06-14</b>
			<b>Revision</b>	<b>02-05-15</b>
	<b>PATRONE MAXI</b>		<b>PATRONENLAGER MINI</b>	
	<p><b>Längen</b></p> <p>L1<sup>1)</sup> = 43.88 -0.20                  L2<sup>1)</sup> = 48.55 -0.20                  L3<sup>1)</sup> = 56.72                  L4 =                  L5 =                  L6 = 70.49</p> <p><b>Hülsenboden</b></p> <p>R = 1.24                  R1 = 12.01                  R3 =                  E = 3.20                  E1 = 10.39                  e min = 0.84                  delta = 36°                  f = 0.38                  beta = 35°</p> <p><b>Pulverkammer</b></p> <p>P1 = 12.02                  P2<sup>1)*</sup> = 10.91 -0.20</p> <p><b>Schulterkonus</b></p> <p>alpha* = 41°30'                  S* = 58.28                  r1 min = 0.76                  r2 = 2.54</p> <p><b>Hülsenhals</b></p> <p>H1* = 7.37                  H2<sup>1)</sup> = 7.37</p> <p><b>Geschoss</b></p> <p>G1<sup>1)</sup> = 6.55                  G2 =                  F =                  L3+G<sup>1)</sup> = 59.85</p> <p><b>Drücke (Energien)</b></p> <p><b>Mech. elektr. Wandler</b></p> <p>Pmax = 3550 bar                  PK = 4083 bar                  PE = 4440 bar                  M = 25.00                  EE = 2850 Joule</p> <p><b>Verschiedene Daten</b></p> <p>Fe<sup>1)</sup> = 0.15                  delta L = 0.15</p>		<p><b>Längen</b></p> <p>L1 = 43.66                  L2 = 48.36                  L3<sup>1)</sup> = 57.25</p> <p><b>Stoßboden</b></p> <p>R =                  R1 = 12.13                  R2 =                  R3 =                  r =</p> <p><b>Pulverkammer</b></p> <p>E = 3.20                  P1<sup>1)</sup> = 12.04                  P2* = 10.96</p> <p><b>Schulterkonus</b></p> <p>alpha<sup>1)*</sup> = 41°18'                  S* = 58.20                  r1 max = 0.76                  r2 = 3.18</p> <p><b>Hülsenhals</b></p> <p>H1* = 7.42                  H2<sup>1)</sup> = 7.39</p> <p><b>Geschossübergang</b></p> <p>G1<sup>1)*</sup> = 6.63                  G<sup>1)</sup> = 3.13                  alpha1* = 90°                  h = 0.38                  s =                  i<sup>1)*</sup> = 2°55'                  w =</p> <p><b>Lauf</b></p> <p>F<sup>1)*</sup> = 6.35                  Z<sup>1)</sup> = 6.50</p> <p><b>Züge</b></p> <p>b = 2.41                  N = 6                  u = 254.00                  Q = 32.78 mm<sup>2</sup></p>	
Maßstab 1:1				
Maße in << mm >> Maße und Toleranzen für Messläufe siehe Anhang CR 1.	Bemerkungen: 1) Kontrolle aus Sicherheitsgründen * Grundmaße			

<b>C.I.P.</b>	<b>260 Rem.</b>		<b>TAB.</b>	<b>I</b>
	Ursprungsland: US		<b>Datum</b>	<b>98-02-09</b>
			<b>Revision</b>	<b>02-05-15</b>
	<b>PATRONE MAXI</b>		<b>PATRONENLAGER MINI</b>	
	<p><b>Längen</b></p> <p>L1<sup>1)</sup> = 39.62 -0.20                  L2<sup>1)</sup> = 45.10 -0.20                  L3<sup>1)</sup> = 51.69                  L4 =                  L5 =                  L6 = 71.12</p> <p><b>Hülsenboden</b></p> <p>R = 1.37                  R1 = 12.01                  R3 =                  E = 3.85                  E1 = 10.39                  e min = 1.40                  delta = 36°                  f = 0.38                  beta = 30°</p> <p><b>Pulverkammer</b></p> <p>P1 = 11.96                  P2<sup>1)*</sup> = 11.53 -0.20</p> <p><b>Schulterkonus</b></p> <p>alpha* = 40°                  S* = 55.46                  r1 min = 0.76                  r2 = 3.18</p> <p><b>Hülsenhals</b></p> <p>H1* = 7.54                  H2<sup>1)</sup> = 7.54</p> <p><b>Geschoss</b></p> <p>G1<sup>1)</sup> = 6.72                  G2 =                  F =                  L3+G<sup>1)</sup> = 57.31</p> <p><b>Drücke (Energien)</b></p> <p><b>Mech. elektr. Wandler</b></p> <p>Pmax = 4150 bar                  PK = 4773 bar                  PE = 5190 bar                  M = 25.00                  EE = 2770 Joule</p> <p><b>Verschiedene Daten</b></p> <p>Fe<sup>1)</sup> = 0.10                  delta L = 0.10</p>		<p><b>Längen</b></p> <p>L1 = 39.48                  L2 = 44.93                  L3<sup>1)</sup> = 51.94</p> <p><b>Stoßboden</b></p> <p>R =                  R1 = 12.03                  R2 =                  R3 =                  r =</p> <p><b>Pulverkammer</b></p> <p>E = 3.85                  P1<sup>1)</sup> = 11.98                  P2* = 11.56</p> <p><b>Schulterkonus</b></p> <p>alpha<sup>1)*</sup> = 40°                  S* = 55.36                  r1 max = 0.76                  r2 = 3.81</p> <p><b>Hülsenhals</b></p> <p>H1* = 7.59                  H2<sup>1)</sup> = 7.57</p> <p><b>Geschossübergang</b></p> <p>G1<sup>1)*</sup> = 6.73                  G<sup>1)</sup> = 5.62                  alpha1 = 90°                  h = 0.42                  s* = 3.43                  i<sup>1)*</sup> = 3°                  w =</p> <p><b>Lauf</b></p> <p>F<sup>1)*</sup> = 6.50                  Z<sup>1)</sup> = 6.71</p> <p><b>Züge</b></p> <p>b = 2.42                  N = 6                  u = 229.00                  Q = 34.74 mm<sup>2</sup></p>	
Maßstab 1:1				
Maße in << mm >> Maße und Toleranzen für Messläufe siehe Anhang CR 1.		Bemerkungen: 1) Kontrolle aus Sicherheitsgründen * Grundmaße		

<b>C.I.P.</b>	<b>264 Leroy N.E.</b>		<b>TAB.</b>	<b>I</b>
	Ursprungsland: DE		<b>Datum</b>	<b>94-03-01</b>
			<b>Revision</b>	<b>02-05-15</b>
	<b>PATRONE MAXI</b>		<b>PATRONENLAGER MINI</b>	
	<p><b>Längen</b></p> <p>L1 <sup>1)</sup>* = 40.96 -0.20</p> <p>L2 <sup>1)</sup>* = 43.45 -0.20</p> <p>L3 <sup>1)</sup> = 51.20</p> <p>L4 =</p> <p>L5 =</p> <p>L6 = 65.00</p> <p><b>Hülsenboden</b></p> <p>R = 1.37</p> <p>R1 = 12.01</p> <p>R3 =</p> <p>E = 3.80</p> <p>E1 = 10.39</p> <p>e min = 0.84</p> <p>delta = 36°</p> <p>f = 0.38</p> <p>beta = 35°</p> <p><b>Pulverkammer</b></p> <p>P1 = 11.97</p> <p>P2 <sup>1)</sup>* = 11.72 -0.20</p> <p><b>Schulterkonus</b></p> <p>alpha = 80°01'02"</p> <p>S = 47.94</p> <p>r1 min =</p> <p>r2 =</p> <p><b>Hülsenhals</b></p> <p>H1 * = 7.54</p> <p>H2 <sup>1)</sup> = 7.54</p> <p><b>Geschoss</b></p> <p>G1 <sup>1)</sup> = 6.70</p> <p>G2 =</p> <p>F =</p> <p>L3+G <sup>1)</sup> = 66.16</p> <p><b>Drücke (Energien)</b></p> <p><b>Mech. elektr. Wandler</b></p> <p>Pmax = 4400 bar</p> <p>PK = 5060 bar</p> <p>PE = 5500 bar</p> <p>M = 25.00</p> <p>EE = 3675 Joule</p> <p><b>Verschiedene Daten</b></p> <p>Fe <sup>1)</sup> = 0.10</p> <p>delta L =</p>		<p><b>Längen</b></p> <p>L1 * = 40.93</p> <p>L2 * = 43.42</p> <p>L3 <sup>1)</sup> = 51.40</p> <p><b>Stoßboden</b></p> <p>R = 1.37</p> <p>R1 = 12.05</p> <p>R2 =</p> <p>R3 =</p> <p>r =</p> <p><b>Pulverkammer</b></p> <p>E = 3.80</p> <p>P1 <sup>1)</sup> = 12.00</p> <p>P2 * = 11.75</p> <p><b>Schulterkonus</b></p> <p>alpha <sup>1)</sup> = 80°09'08"</p> <p>S = 47.91</p> <p>r1 max =</p> <p>r2 =</p> <p><b>Hülsenhals</b></p> <p>H1 * = 7.56</p> <p>H2 <sup>1)</sup> = 7.56</p> <p><b>Geschossübergang</b></p> <p>G1 <sup>1)</sup>* = 6.71</p> <p>G <sup>1)</sup>* = 14.96</p> <p>alpha1 = 180°</p> <p>h =</p> <p>s * = 10.00</p> <p>i <sup>1)</sup> = 1°30'05"</p> <p>w =</p> <p><b>Lauf</b></p> <p>F <sup>1)</sup>* = 6.45</p> <p>Z <sup>1)</sup> = 6.70</p> <p><b>Züge</b></p> <p>b = 1.30</p> <p>N = 4</p> <p>u = 200.00</p> <p>Q = 33.33 mm<sup>2</sup></p>	
<p>Maßstab 1:1</p> <p>Maße in &lt;&lt; mm &gt;&gt;</p> <p>Maße und Toleranzen für Messläufe siehe Anhang CR 1.</p>		<p>Bemerkungen: 1) Kontrolle aus Sicherheitsgründen * Grundmaße</p>		

<b>C.I.P.</b>	<b>270 Win.</b>		<b>TAB.</b>	<b>I</b>
	Ursprungsland: US		<b>Datum</b>	<b>84-06-14</b>
			<b>Revision</b>	<b>02-05-15</b>
	<b>PATRONE MAXI</b>		<b>PATRONENLAGER MINI</b>	
	<p><b>Längen</b></p> <p>L1<sup>1)</sup> = 49.49 -0.20                  L2<sup>1)</sup> = 54.77 -0.20                  L3<sup>1)</sup> = 64.52                  L4 =                  L5 =                  L6 = 84.84</p> <p><b>Hülsenboden</b></p> <p>R = 1.24                  R1 = 12.01                  R3 =                  E = 3.16                  E1 = 10.39                  e min = 0.84                  delta = 36°                  f = 0.38                  beta = 35°</p> <p><b>Pulverkammer</b></p> <p>P1 = 11.96                  P2<sup>1)*</sup> = 11.20 -0.20</p> <p><b>Schulterkonus</b></p> <p>alpha* = 35°                  S* = 67.25                  r1 min = 0.76                  r2 = 3.81</p> <p><b>Hülsenhals</b></p> <p>H1* = 7.87                  H2<sup>1)</sup> = 7.82</p> <p><b>Geschoss</b></p> <p>G1<sup>1)</sup> = 7.06                  G2 =                  F =                  L3+G<sup>1)</sup> = 72.61</p> <p><b>Drücke (Energien)</b></p> <p><b>Mech. elektr. Wandler</b></p> <p>Pmax = 4300 bar                  PK = 4945 bar                  PE = 5375 bar                  M = 25.00                  EE = 3840 Joule</p> <p><b>Verschiedene Daten</b></p> <p>Fe<sup>1)</sup> = 0.10                  delta L = 0.15</p>		<p><b>Längen</b></p> <p>L1 = 49.28                  L2 = 54.68                  L3<sup>1)</sup> = 65.02</p> <p><b>Stoßboden</b></p> <p>R =                  R1 = 12.04                  R2 =                  R3 =                  r =</p> <p><b>Pulverkammer</b></p> <p>E = 3.16                  P1<sup>1)</sup> = 11.99                  P2* = 11.24</p> <p><b>Schulterkonus</b></p> <p>alpha<sup>1)*</sup> = 34°30'                  S* = 67.38                  r1 max = 0.76                  r2 = 3.81</p> <p><b>Hülsenhals</b></p> <p>H1* = 7.89                  H2<sup>1)</sup> = 7.84</p> <p><b>Geschossübergang</b></p> <p>G1<sup>1)*</sup> = 7.07                  G<sup>1)</sup> = 8.09                  alpha* = 74°40'12"                  h = 0.50                  s =                  i<sup>1)*</sup> = 0°47'33"                  w =</p> <p><b>Lauf</b></p> <p>F<sup>1)*</sup> = 6.86                  Z<sup>1)</sup> = 7.04</p> <p><b>Züge</b></p> <p>b = 4.06                  N = 4                  u = 254.00                  Q = 38.52 mm<sup>2</sup></p>	
Maßstab 1:1				
Maße in << mm >> Maße und Toleranzen für Messläufe siehe Anhang CR 1.	Bemerkungen: 1) Kontrolle aus Sicherheitsgründen * Grundmaße			

<b>C.I.P.</b>	<b>270 Win. Short Mag.</b>	<b>TAB. I</b>	
		<b>Datum</b>	<b>02-01-22</b>
		<b>Revision</b>	<b>08-09-23</b>
Ursprungsland: US			
	<b>PATRONE MAXI</b>		<b>PATRONENLAGER MINI</b>
	<p><b>Längen</b></p> <p>L1 <sup>1)</sup> = 42.25 -0.20                  L2 <sup>1)</sup> = 46.31 -0.20                  L3 <sup>1)</sup> = 53.34                  L4 =                  L5 =                  L6 = 72.64</p> <p><b>Hülsenboden</b></p> <p>R = 1.37                  R1 = 13.59                  R3 =                  E = 3.35                  E1 = 12.19                  e min = 1.02                  delta = 45°                  f = 0.36                  beta = 35°</p> <p><b>Pulverkammer</b></p> <p>P1 = 14.12                  P2 <sup>1)</sup>* = 13.67 -0.20</p> <p><b>Schulterkonus</b></p> <p>alpha * = 70°                  S * = 52.01                  r1 min = 1.27                  r2 = 2.54</p> <p><b>Hülsenhals</b></p> <p>H1 * = 7.98                  H2 <sup>1)</sup> = 7.98</p> <p><b>Geschoss</b></p> <p>G1 <sup>1)</sup> = 7.06                  G2 =                  F =                  L3+G <sup>1)</sup> = 57.82</p> <p><b>Drücke (Energien)</b></p> <p><b>Mech. elektr. Wandler</b></p> <p>Pmax = 4400 bar                  PK = 5060 bar                  PE = 5500 bar                  M = 25.00                  EE = 4725 Joule</p> <p><b>Verschiedene Daten</b></p> <p>Fe <sup>1)3)</sup> = 0.10                  delta L = 0.10</p>		<p><b>Längen</b></p> <p>L1 = 42.13                  L2 = 46.18                  L3 <sup>1)</sup> = 53.59</p> <p><b>Stoßboden</b></p> <p>R =                  R1 = 14.19                  R2 =                  R3 =                  r =</p> <p><b>Pulverkammer</b></p> <p>E = 3.35                  P1 <sup>1)</sup> = 14.15                  P2 * = 13.70</p> <p><b>Schulterkonus</b></p> <p>alpha <sup>1)</sup>* = 70°                  S * = 51.91                  r1 max = 1.27                  r2 = 3.05</p> <p><b>Hülsenhals</b></p> <p>H1 * = 8.03                  H2 <sup>1)</sup> = 8.00</p> <p><b>Geschossübergang</b></p> <p>G1 <sup>1)</sup>* = 7.07                  G <sup>1)</sup> = 4.48                  alpha 1 = 90°                  h * = 0.47                  s =                  i <sup>1)</sup>* = 1°30'                  w =</p> <p><b>Lauf</b></p> <p>F <sup>1)</sup>* = 6.86                  Z <sup>1)</sup> = 7.04</p> <p><b>Züge</b></p> <p>b = 4.06                  N = 4                  u = 254.00                  Q = 38.52 mm<sup>2</sup></p>
Maßstab 1.03:1  Maße in << mm >> Maße und Toleranzen für Messläufe siehe Anhang CR 1.		Bemerkungen: 1) Kontrolle aus Sicherheitsgründen 3) Verschlussabstand an Schulter * Grundmaße	

<b>C.I.P.</b>	<b>275 H. V. Rigby</b>		<b>TAB.</b>	<b>I</b>
	Ursprungsland: GB		<b>Datum</b>	<b>84-06-14</b>
			<b>Revision</b>	<b>02-05-15</b>
	<b>PATRONE MAXI</b>		<b>PATRONENLAGER MINI</b>	
	<p><b>Längen</b></p> <p>L1 <sup>1)</sup>* = 43.79 -0.20</p> <p>L2 <sup>1)</sup>* = 47.35 -0.20</p> <p>L3 <sup>1)</sup> = 56.90</p> <p>L4 =</p> <p>L5 =</p> <p>L6 = 77.98</p> <p><b>Hülsenboden</b></p> <p>R = 1.09</p> <p>R1 = 12.06</p> <p>R3 =</p> <p>E = 2.97</p> <p>E1 = 10.54</p> <p>e min = 0.81</p> <p>δ = 35°01'48"</p> <p>f =</p> <p>β =</p> <p><b>Pulverkammer</b></p> <p>P1 = 12.04</p> <p>P2 <sup>1)</sup>* = 10.87 -0.20</p> <p><b>Schulterkonus</b></p> <p>α = 40°41'17"</p> <p>S = 58.45</p> <p>r1 min =</p> <p>r2 =</p> <p><b>Hülsenhals</b></p> <p>H1* = 8.23</p> <p>H2 <sup>1)</sup> = 8.23</p> <p><b>Geschoss</b></p> <p>G1 <sup>1)</sup> = 7.21</p> <p>G2 =</p> <p>F =</p> <p>L3+G <sup>1)</sup> = 62.55</p> <p><b>Drücke (Energien)</b></p> <p><b>Mech. elektr. Wandler</b></p> <p>Pmax = 3200 bar</p> <p>PK = 3680 bar</p> <p>PE = 4000 bar</p> <p>M = 25.00</p> <p>EE = 2720 Joule</p> <p><b>Verschiedene Daten</b></p> <p>Fe <sup>1)</sup> = 0.15</p> <p>delta L =</p>		<p><b>Längen</b></p> <p>L1* = 43.74</p> <p>L2* = 47.29</p> <p>L3 <sup>1)</sup> = 57.20</p> <p><b>Stoßboden</b></p> <p>R = 1.09</p> <p>R1 = 12.12</p> <p>R2 =</p> <p>R3 =</p> <p>r =</p> <p><b>Pulverkammer</b></p> <p>E = 2.97</p> <p>P1 <sup>1)</sup> = 12.07</p> <p>P2* = 10.90</p> <p><b>Schulterkonus</b></p> <p>α <sup>1)</sup> = 40°47'36"</p> <p>S = 58.40</p> <p>r1 max =</p> <p>r2 =</p> <p><b>Hülsenhals</b></p> <p>H1* = 8.26</p> <p>H2 <sup>1)</sup> = 8.26</p> <p><b>Geschossübergang</b></p> <p>G1 <sup>1)</sup>* = 7.26</p> <p>G <sup>1)</sup>* = 5.65</p> <p>α1 = 90°</p> <p>h* = 0.50</p> <p>s =</p> <p>i <sup>1)</sup> = 1°36'46"</p> <p>w =</p> <p><b>Lauf</b></p> <p>F <sup>1)</sup>* = 6.97</p> <p>Z <sup>1)</sup> = 7.25</p> <p><b>Züge</b></p> <p>b = 3.62</p> <p>N = 4</p> <p>u = 203.00</p> <p>Q = 40.28 mm<sup>2</sup></p>	
Maßstab 1:1				
<p>Maße in &lt;&lt; mm &gt;&gt;</p> <p>Maße und Toleranzen für Messläufe siehe Anhang CR 1.</p>		<p>Bemerkungen: 1) Kontrolle aus Sicherheitsgründen * Grundmaße</p>		

<b>C.I.P.</b>	<b>277 GS</b>		<b>TAB.</b>	<b>I</b>
	Ursprungsland: IT		<b>Datum</b>	<b>96-11-26</b>
			<b>Revision</b>	<b>11-05-25</b>
	<b>PATRONE MAXI</b>		<b>PATRONENLAGER MINI</b>	
	<p><b>Längen</b></p> <p>L1 <sup>1)*</sup> = 56.50 -0.20                      L2 <sup>1)*</sup> = 59.97 -0.20                      L3 <sup>1)</sup> = 67.00                      L4 =                      L5 =                      L6 = 87.00</p> <p><b>Hülsenboden</b></p> <p>R = 1.40                      R1 = 13.00                      R3 =                      E = 3.50                      E1 = 11.20                      e min = 1.00                      δ = 43°40'04"                      f = 0.30                      β = 45°</p> <p><b>Pulverkammer</b></p> <p>P1 = 13.30                      P2 <sup>1)*</sup> = 12.80 -0.20</p> <p><b>Schulterkonus</b></p> <p>α = 70°                      S = 65.64                      r1 min = 0.50                      r2 = 0.50</p> <p><b>Hülsenhals</b></p> <p>H1 * = 7.94                      H2 <sup>1)</sup> = 7.94</p> <p><b>Geschoss</b></p> <p>G1 <sup>1)</sup> = 7.06                      G2 =                      F =                      L3+G <sup>1)</sup> = 73.00</p> <p><b>Drücke (Energien)</b></p> <p><b>Mech. elektr. Wandler</b></p> <p>Pmax = 4400 bar                      PK = 5060 bar                      PE = 5500 bar                      M = 25.00                      EE = 4883 Joule</p> <p><b>Verschiedene Daten</b></p> <p>Fe <sup>1)3)</sup> = 0.10                      delta L =</p>		<p><b>Längen</b></p> <p>L1 * = 56.48                      L2 * = 59.95                      L3 <sup>1)</sup> = 67.30</p> <p><b>Stoßboden</b></p> <p>R = 1.40                      R1 = 13.05                      R2 =                      R3 =                      r =</p> <p><b>Pulverkammer</b></p> <p>E = 3.50                      P1 <sup>1)*</sup> = 13.33                      P2 = 12.83</p> <p><b>Schulterkonus</b></p> <p>α <sup>1)</sup> = 70°                      S = 65.64                      r1 max = 0.50                      r2 = 0.50</p> <p><b>Hülsenhals</b></p> <p>H1 * = 7.98                      H2 <sup>1)</sup> = 7.96</p> <p><b>Geschossübergang</b></p> <p>G1 <sup>1)*</sup> = 7.07                      G <sup>1)*</sup> = 6.00                      α1 = 180°                      h =                      s =                      i <sup>1)</sup> = 1°                      w =</p> <p><b>Lauf</b></p> <p>F <sup>1)*</sup> = 6.86                      Z <sup>1)</sup> = 7.04</p> <p><b>Züge</b></p> <p>b = 4.06                      N = 4                      u = 254.00                      Q = 38.52 mm<sup>2</sup></p>	
	<p>Maßstab 1:1.06</p> <p style="text-align: center;">Maße in &lt;&lt; mm &gt;&gt; Maße und Toleranzen für Messläufe siehe Anhang CR 1.</p>			
		<p>Bemerkungen: 1) Kontrolle aus Sicherheitsgründen                      3) Verschlussabstand an Schulter                      * Grundmaße</p>		

C.I.P.	280 Rem. Ursprungsland: US	TAB.	I
		Datum	84-06-14
		Revision	02-05-15
	<b>PATRONE MAXI</b>		<b>PATRONENLAGER MINI</b>
	<b>Längen</b> L1 <sup>1)</sup> = 50.78 -0.20 L2 <sup>1)</sup> = 55.87 -0.20 L3 <sup>1)</sup> = 64.52 L4 = L5 = L6 = 84.58  <b>Hülsenboden</b> R = 1.24 R1 = 12.01 R3 = E = 3.17 E1 = 10.39 e min = 0.84 delta = 36° f = 0.38 beta = 35°  <b>Pulverkammer</b> P1 = 11.97 P2 <sup>1)*</sup> = 11.21 -0.20  <b>Schulterkonus</b> alpha* = 35° S* = 68.56 r1 min = 0.64 r2 = 2.54  <b>Hülsenhals</b> H1* = 8.00 H2 <sup>1)</sup> = 8.00  <b>Geschoss</b> G1 <sup>1)</sup> = 7.23 G2 = F = L3+G <sup>1)</sup> = 69.27  <b>Drücke (Energien)</b> <b>Mech. elektr. Wandler</b> Pmax = 4050 bar PK = 4658 bar PE = 5060 bar M = 25.00 EE = 3930 Joule  <b>Verschiedene Daten</b> Fe <sup>1)</sup> = 0.10 delta L = 0.14		<b>Längen</b> L1 = 50.61 L2 = 55.70 L3 <sup>1)</sup> = 65.02  <b>Stoßboden</b> R = R1 = 12.06 R2 = R3 = r =  <b>Pulverkammer</b> E = 3.17 P1 <sup>1)</sup> = 12.00 P2* = 11.23  <b>Schulterkonus</b> alpha <sup>1)*</sup> = 34°30' S* = 68.69 r1 max = 0.64 r2 = 3.18  <b>Hülsenhals</b> H1* = 8.07 H2 <sup>1)</sup> = 8.02  <b>Geschossübergang</b> G1 <sup>1)*</sup> = 7.25 G <sup>1)</sup> = 4.75 alpha1* = 90° h = 0.39 s = i <sup>1)*</sup> = 1°22'34" w =  <b>Lauf</b> F <sup>1)*</sup> = 7.04 Z <sup>1)</sup> = 7.21  <b>Züge</b> b = 4.06 N = 4 u = 254.00 Q = 40.39 mm <sup>2</sup>
	<b>Maßstab 1:1</b>  Maße in << mm >> Maße und Toleranzen für Messläufe siehe Anhang CR 1.		
Bemerkungen: 1) Kontrolle aus Sicherheitsgründen * Grundmaße			



<b>C.I.P.</b>	<b>280 Riml. N. E. Ross</b>	<b>TAB.</b>	<b>I</b>
		<b>Datum</b>	<b>84-06-14</b>
		<b>Revision</b>	<b>02-05-15</b>
Ursprungsland: GB			
	<b>PATRONE MAXI</b>	<b>PATRONENLAGER MINI</b>	
	<p><b>Längen</b></p> <p>L1 <sup>1)</sup>* = 55.40 -0.20                  L2 <sup>1)</sup>* = 57.99 -0.20                  L3 <sup>1)</sup> = 66.32                  L4 =                  L5 =                  L6 = 87.88</p> <p><b>Hülsenboden</b></p> <p>R = 1.52                  R1 = 14.22                  R3 =                  E = 3.58                  E1 = 12.45                  e min = 1.02                  delta = 28°43'48"                  f =                  beta =</p> <p><b>Pulverkammer</b></p> <p>P1 = 13.59                  P2 <sup>1)</sup>* = 10.72 -0.20</p> <p><b>Schulterkonus</b></p> <p>alpha = 53°07'48"                  S = 66.12                  r1 min =                  r2 =</p> <p><b>Hülsenhals</b></p> <p>H1* = 8.13                  H2 <sup>1)</sup> = 8.13</p> <p><b>Geschoss</b></p> <p>G1 <sup>1)</sup> = 7.29                  G2 =                  F =                  L3+G <sup>1)</sup> = 72.27</p> <p><b>Drücke (Energien)</b></p> <p><b>Mech. elektr. Wandler</b></p> <p>Pmax = 3250 bar                  PK = 3738 bar                  PE = 4060 bar                  M = 25.00                  EE = 4440 Joule</p> <p><b>Verschiedene Daten</b></p> <p>Fe <sup>1)</sup> = 0.15                  delta L =</p>	<p><b>Längen</b></p> <p>L1* = 55.35                  L2* = 57.94                  L3 <sup>1)</sup> = 66.62</p> <p><b>Stoßboden</b></p> <p>R = 1.52                  R1 = 14.27                  R2 =                  R3 =                  r =</p> <p><b>Pulverkammer</b></p> <p>E = 3.58                  P1 <sup>1)</sup> = 13.61                  P2* = 10.74</p> <p><b>Schulterkonus</b></p> <p>alpha <sup>1)</sup> = 53°07'48"                  S = 66.09                  r1 max =                  r2 =</p> <p><b>Hülsenhals</b></p> <p>H1* = 8.15                  H2 <sup>1)</sup> = 8.15</p> <p><b>Geschossübergang</b></p> <p>G1 <sup>1)</sup>* = 7.34                  G <sup>1)</sup>* = 5.95                  alpha1 = 90°                  h* = 0.41                  s =                  i <sup>1)</sup> = 1°29'57"                  w =</p> <p><b>Lauf</b></p> <p>F <sup>1)</sup>* = 7.05                  Z <sup>1)</sup> = 7.30</p> <p><b>Züge</b></p> <p>b =                  N =                  u = 220.00                  Q = 39.04 mm<sup>2</sup></p>	
Maßstab 1:1			
Maße in << mm >> Maße und Toleranzen für Messläufe siehe Anhang CR 1.		Bemerkungen: 1) Kontrolle aus Sicherheitsgründen * Grundmaße	

<b>C.I.P.</b>	<b>284 Tony</b> Ursprungsland: IT	TAB.	I
		Datum	16-10-18
		Revision	
	<b>PATRONE MAXI</b>	<b>PATRONENLAGER MINI</b>	
	<p><b>Längen</b></p> <p>L1 <sup>1)</sup> = 44.74 -0.20                  L2 <sup>1)</sup> = 47.80 -0.20                  L3 <sup>1)</sup> = 54.87                  L4 =                  L5 =                  L6 = 78.00</p> <p><b>Hülsenboden</b></p> <p>R = 1.37                  R1 = 12.01                  R3 =                  E = 3.76                  E1 = 10.39                  e min = 1.02                  delta = 40°                  f = 0.38                  beta = 35°</p> <p><b>Pulverkammer</b></p> <p>P1 = 12.69                  P2 <sup>1)</sup>* = 12.29 -0.20</p> <p><b>Schulterkonus</b></p> <p>alpha * = 70°                  S * = 53.51                  r1 min = 0.76                  r2 = 3.17</p> <p><b>Hülsenhals</b></p> <p>H1 * = 8.00                  H2 <sup>1)</sup> = 8.00</p> <p><b>Geschoss</b></p> <p>G1 <sup>1)</sup> = 7.21                  G2 =                  F =                  L3+G <sup>1)</sup> = 60.58</p> <p><b>Drücke (Energien)</b>  <b>Mech. elektr. Wandler</b></p> <p>Pmax = 4400 bar                  PK = 5060 bar                  PE = 5500 bar                  M = 25.00                  EE = 4300 Joule</p> <p><b>Verschiedene Daten</b></p> <p>Fe <sup>1)3)</sup> = 0.10                  delta L =</p>	<p><b>Längen</b></p> <p>L1 = 44.79                  L2 = 47.84                  L3 <sup>1)</sup> = 54.99</p> <p><b>Stoßboden</b></p> <p>R =                  R1 = 12.92                  R2 =                  R3 =                  r =</p> <p><b>Pulverkammer</b></p> <p>E = 3.76                  P1 <sup>1)</sup> = 12.77                  P2 * = 12.32</p> <p><b>Schulterkonus</b></p> <p>alpha <sup>1)</sup>* = 70°                  S * = 53.59                  r1 max = 0.76                  r2 = 3.17</p> <p><b>Hülsenhals</b></p> <p>H1 * = 8.05                  H2 <sup>1)</sup> = 8.05</p> <p><b>Geschossübergang</b></p> <p>G1 <sup>1)</sup>* = 7.23                  G <sup>1)</sup> = 5.71                  alpha1 = 90°                  h * = 0.41                  s =                  i <sup>1)</sup>* = 1°11'20"                  w =</p> <p><b>Lauf</b></p> <p>F <sup>1)</sup>* = 7.01                  Z <sup>1)</sup> = 7.21</p> <p><b>Züge</b></p> <p>b = 2.79                  N = 4                  u = 228.00                  Q = 39.74 mm<sup>2</sup></p>	
Maßstab 1.04:1  Maße in << mm >> Maße und Toleranzen für Messläufe siehe Anhang CR1.		Bemerkungen: 1) Kontrolle aus Sicherheitsgründen 3) Verschlussabstand an Schulter * Grundmaße	

<b>C.I.P.</b>	<b>284 Win.</b>	<b>TAB.</b>	<b>I</b>
		<b>Datum</b>	<b>84-06-14</b>
		<b>Revision</b>	<b>05-05-25</b>
		<p><b>URSPRUNGSLAND: US</b></p>	
		<p><b>PATRONENLAGER MINI</b></p>	
<p><b>Maßstab 1:1</b></p> <p>Maße in &lt;&lt; mm &gt;&gt; Maße und Toleranzen für Messläufe siehe Anhang CR 1.</p>		<p><b>PATRONENLager MINI</b></p> <p><b>Längen</b></p> <p>L1 = 44.96 L2 = 47.73 L3 = 55.37</p> <p><b>Stoßboden</b></p> <p>R = R1 = 12.81 R2 = R3 = r =</p> <p><b>Pulverkammer</b></p> <p>E = 3.78 P1 = 12.75 P2 = 12.09</p> <p><b>Schulterkonus</b></p> <p>alpha = 70° S = 53.59 r1 max = 0.76 r2 = 3.18</p> <p><b>HülseHals</b></p> <p>H1 = 8.20 H2 = 8.18</p> <p><b>Geschossübergang</b></p> <p>G1 = 7.37 G = 13.78 alpha = 90° h = 0.41 s = i = 0°47'33" w =</p> <p><b>Lauf</b></p> <p>F = 7.00 Z = 7.19</p> <p><b>Züge</b></p> <p>b = 2.79 N = 6 u = 254.00 Q = 40.12 mm²</p>	
<p><b>Maßstab 1:1</b></p> <p>Maße in &lt;&lt; mm &gt;&gt; Maße und Toleranzen für Messläufe siehe Anhang CR 1.</p>		<p><b>PATRONENLager MAXI</b></p> <p><b>Längen</b></p> <p>L1 = 45.08 -0.20 L2 = 47.88 -0.20 L3 = 55.12 L4 = L5 = L6 = 71.12</p> <p><b>HülseHoden</b></p> <p>R = 1.37 R1 = 12.01 R3 = E = 3.78 E1 = 10.39 e min = 1.02 delta = 40° f = 0.38 beta = 35°</p> <p><b>Pulverkammer</b></p> <p>P1 = 12.72 P2 = 12.06 -0.20</p> <p><b>Schulterkonus</b></p> <p>alpha = 70° S = 53.69 r1 min = 0.76 r2 = 3.18</p> <p><b>HülseHals</b></p> <p>H1 = 8.13 H2 = 8.13</p> <p><b>Geschoss</b></p> <p>G1 = 7.21 G2 = F = L3+G = 68.90</p> <p><b>Drücke (Energien)</b></p> <p><b>Mech. elektr. Wandler</b></p> <p>Pmax = 4400 bar PK = 5060 bar PE = 5500 bar M = 25.00 EE = 3625 Joule</p> <p><b>Verschiedene Daten</b></p> <p>Fe = 0.10 delta L = 0.10</p>	
<p><b>Bemerkungen:</b></p> <p>1) Kontrolle aus Sicherheitsgründen * Grundmaße</p>			

<b>C.I.P.</b>	<b>30 BR</b>		<b>TAB.</b>	<b>I</b>
	Ursprungsland: US		Datum	11-05-25
			Revision	
	<b>PATRONE MAXI</b>		<b>PATRONENLAGER MINI</b>	
	<p><b>Längen</b></p> <p>L1 <sup>1)</sup> = 27.17 -0.20                      L2 <sup>1)</sup> = 30.05 -0.20                      L3 <sup>1)</sup> = 38.41                      L4 =                      L5 =                      L6 = 58.00</p> <p><b>Hülsenboden</b></p> <p>R = 1.37                      R1 = 12.01                      R3 =                      E = 3.83                      E1 = 10.40                      e min = 1.40                      delta = 36°                      f = 0.40                      beta = 45°</p> <p><b>Pulverkammer</b></p> <p>P1 = 11.94                      P2 <sup>1)</sup>* = 11.66 -0.20</p> <p><b>Schulterkonus</b></p> <p>alpha * = 60°                      S * = 37.25                      r1 min = 0.64                      r2 = 1.50</p> <p><b>Hülsenhals</b></p> <p>H1 * = 8.33                      H2 <sup>1)</sup> = 8.33</p> <p><b>Geschoss</b></p> <p>G1 <sup>1)</sup> = 7.82                      G2 =                      F =                      L3+G <sup>1)</sup> = 42.69</p> <p><b>Drücke (Energien)</b></p> <p><b>Mech. elektr. Wandler</b></p> <p>Pmax = 4050 bar                      PK = 4658 bar                      PE = 5063 bar                      M = 17.50                      EE = 3200 Joule</p> <p><b>Verschiedene Daten</b></p> <p>Fe <sup>1)3)</sup> = 0.10                      delta L =</p>		<p><b>Längen</b></p> <p>L1 = 27.20                      L2 = 30.08                      L3 <sup>1)</sup> = 38.61</p> <p><b>Stoßboden</b></p> <p>R =                      R1 = 12.02                      R2 =                      R3 =                      r =</p> <p><b>Pulverkammer</b></p> <p>E = 3.83                      P1 <sup>1)</sup> = 11.99                      P2 * = 11.71</p> <p><b>Schulterkonus</b></p> <p>alpha <sup>1)</sup>* = 60°                      S * = 37.33                      r1 max = 0.64                      r2 = 1.90</p> <p><b>Hülsenhals</b></p> <p>H1 * = 8.38                      H2 <sup>1)</sup> = 8.38</p> <p><b>Geschossübergang</b></p> <p>G1 <sup>1)</sup>* = 7.83                      G <sup>1)</sup> = 4.28                      alpha l = 90°                      h = 0.28                      s =                      i <sup>1)</sup>* = 1°30'                      w =</p> <p><b>Lauf</b></p> <p>F <sup>1)</sup>* = 7.62                      Z <sup>1)</sup> = 7.82</p> <p><b>Züge</b></p> <p>b = 2.50                      N = 6                      u = 431.80                      Q = 47.13 mm<sup>2</sup></p>	
<p>Maßstab 1.14:1</p> <p style="text-align: center;">Maße in &lt;&lt; mm &gt;&gt;                      Maße und Toleranzen für Messläufe                      siehe Anhang CR 1.</p>			<p>Bemerkungen: 1) Kontrolle aus Sicherheitsgründen                      3) Verschlussabstand an Schulter                      * Grundmaße</p>	

<b>C.I.P.</b>	<b>30 Carbine</b> Ursprungsland: US	<b>TAB.</b>	<b>I</b>
		<b>Datum</b>	<b>84-06-14</b>
		<b>Revision</b>	<b>02-05-15</b>
	<b>PATRONE MAXI</b>	<b>PATRONENLAGER MINI</b>	
	<p><b>Längen</b></p> <p>L1 =</p> <p>L2 =</p> <p>L3 <sup>1)</sup> = 32.77 -0.25</p> <p>L4 =</p> <p>L5 =</p> <p>L6 = 42.67</p> <p><b>Hülsenboden</b></p> <p>R = 1.27</p> <p>R1 = 9.14</p> <p>R3 =</p> <p>E = 2.90</p> <p>E1 = 7.87</p> <p>e min = 0.84</p> <p>delta = 37°</p> <p>f = 0.38</p> <p>beta = 35°</p> <p><b>Pulverkammer</b></p> <p>P1 = 9.06</p> <p>P2 =</p> <p><b>Schulterkonus</b></p> <p>alpha =</p> <p>S =</p> <p>r1 min =</p> <p>r2 =</p> <p><b>Hülsenhals</b></p> <p>H1 =</p> <p>H2 <sup>1)</sup> = 8.53</p> <p><b>Geschoss</b></p> <p>G1 <sup>1)</sup> = 7.85</p> <p>G2 =</p> <p>F =</p> <p>L3+G <sup>1)</sup> = 36.68</p> <p><b>Drücke (Energien)</b></p> <p><b>Mech. elektr. Wandler</b></p> <p>Pmax = 3200 bar</p> <p>PK = 3680 bar</p> <p>PE = 4000 bar</p> <p>M = 17.50</p> <p>EE = 1375 Joule</p> <p><b>Verschiedene Daten</b></p> <p>Fe <sup>1)</sup> = 0.15</p> <p>delta L =</p>	<p>Längen</p> <p>L1 =</p> <p>L2 =</p> <p>L3 <sup>1)</sup> = 32.77</p> <p><b>Stoßboden</b></p> <p>R = 1.27</p> <p>R1 = 9.40</p> <p>R2 =</p> <p>R3 =</p> <p>r =</p> <p><b>Pulverkammer</b></p> <p>E = 2.90</p> <p>P1 <sup>1)</sup> = 9.15</p> <p>P2 =</p> <p><b>Schulterkonus</b></p> <p>alpha =</p> <p>S =</p> <p>r1 max =</p> <p>r2 =</p> <p><b>Hülsenhals</b></p> <p>H1 =</p> <p>H2 <sup>1)</sup> = 8.60</p> <p><b>Geschossübergang</b></p> <p>G1 <sup>1)</sup>* = 7.96</p> <p>G <sup>1)</sup> = 3.91</p> <p>alpha1 = 180°</p> <p>h =</p> <p>s =</p> <p>i <sup>1)</sup>* = 2°29'27"</p> <p>w =</p> <p><b>Lauf</b></p> <p>F <sup>1)</sup>* = 7.62</p> <p>Z <sup>1)</sup> = 7.82</p> <p><b>Züge</b></p> <p>b = 4.24</p> <p>N = 4</p> <p>u = 508.00</p> <p>Q = 47.40 mm<sup>2</sup></p>	
Maßstab 1.5:1			
<p>Maße in &lt;&lt; mm &gt;&gt;</p> <p>Maße und Toleranzen für Messläufe siehe Anhang CR 1.</p>	<p>Bemerkungen: 1) Kontrolle aus Sicherheitsgründen * Grundmaße</p>		

C.I.P.	30 Court Ursprungsland: DE	TAB.	I
		Datum	91-05-17
		Revision	02-05-15
	<p><b>PATRONE MAXI</b></p> <p><b>Längen</b></p> <p>L1 =</p> <p>L2 =</p> <p>L3<sup>1)</sup> = 31.45 -0.25</p> <p>L4 =</p> <p>L5 =</p> <p>L6 = 41.35</p> <p><b>Hülsenboden</b></p> <p>R = 1.27</p> <p>R1 = 9.14</p> <p>R3 =</p> <p>E = 2.90</p> <p>E1 = 7.87</p> <p>e min = 0.84</p> <p>delta = 37°</p> <p>f = 0.38</p> <p>beta = 45°</p> <p><b>Pulverkammer</b></p> <p>P1 = 9.06</p> <p>P2 =</p> <p><b>Schulterkonus</b></p> <p>alpha =</p> <p>S =</p> <p>r1 min =</p> <p>r2 =</p> <p><b>Hülsenhals</b></p> <p>H1 =</p> <p>H2<sup>1)</sup> = 8.55</p> <p><b>Geschoss</b></p> <p>G1<sup>1)</sup> = 7.85</p> <p>G2 =</p> <p>F =</p> <p>L3+G<sup>1)</sup> = 35.36</p> <p><b>Drücke (Energien)</b></p> <p><b>Mech. elektr. Wandler</b></p> <p>Pmax = 3650 bar</p> <p>PK = 4198 bar</p> <p>PE = 4560 bar</p> <p>M = 17.50</p> <p>EE = 1470 Joule</p> <p><b>Verschiedene Daten</b></p> <p>Fe<sup>1)</sup> = 0.15</p> <p>delta L =</p>	<p><b>PATRONELAGER MINI</b></p> <p><b>Längen</b></p> <p>L1 =</p> <p>L2 =</p> <p>L3<sup>1)</sup> = 31.45</p> <p><b>Stoßboden</b></p> <p>R = 1.27</p> <p>R1 = 9.40</p> <p>R2 =</p> <p>R3 =</p> <p>r =</p> <p><b>Pulverkammer</b></p> <p>E = 2.90</p> <p>P1<sup>1)</sup> = 9.13</p> <p>P2 =</p> <p><b>Schulterkonus</b></p> <p>alpha =</p> <p>S =</p> <p>r1 max =</p> <p>r2 =</p> <p><b>Hülsenhals</b></p> <p>H1 =</p> <p>H2<sup>1)</sup> = 8.60</p> <p><b>Geschossübergang</b></p> <p>G1<sup>1)*</sup> = 7.96</p> <p>G<sup>1)*</sup> = 3.91</p> <p>alpha1 = 180°</p> <p>h =</p> <p>s =</p> <p>i<sup>1)</sup> = 2°29'22"</p> <p>w =</p> <p><b>Lauf</b></p> <p>F<sup>1)*</sup> = 7.62</p> <p>Z<sup>1)</sup> = 7.82</p> <p><b>Züge</b></p> <p>b = 4.24</p> <p>N = 4</p> <p>u = 508.00</p> <p>Q = 47.40 mm<sup>2</sup></p>	
Maßstab 1.5:1			
<p>Maße in &lt;&lt; mm &gt;&gt;</p> <p>Maße und Toleranzen für Messläufe siehe Anhang CR 1.</p>	<p>Bemerkungen: 1) Kontrolle aus Sicherheitsgründen * Grundmaße</p>		

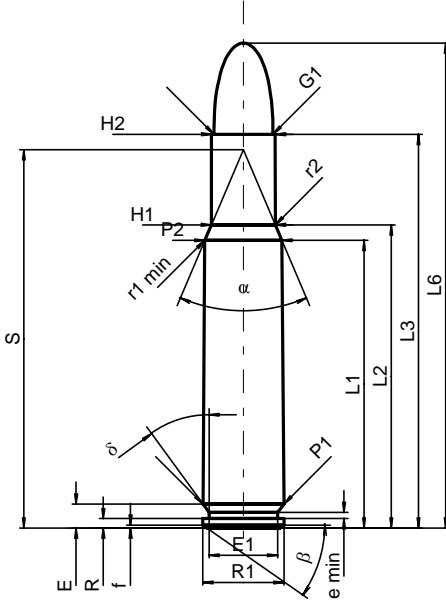
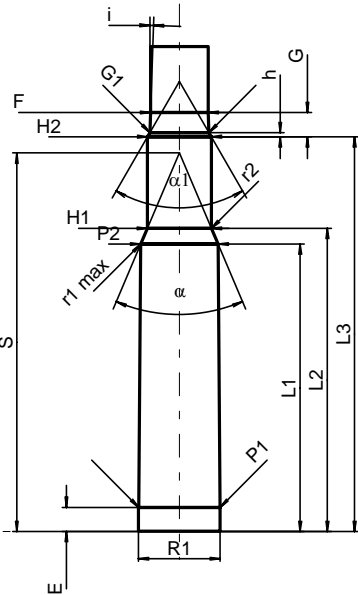
<b>C.I.P.</b>	<b>30 Rem.</b>		<b>TAB.</b>	<b>I</b>
	Ursprungsland: US		<b>Datum</b>	<b>84-06-14</b>
			<b>Revision</b>	<b>02-05-15</b>
	<b>PATRONE MAXI</b>		<b>PATRONENLAGER MINI</b>	
	<b>Längen</b> L1 <sup>1)</sup> = 38.05 -0.20 L2 <sup>1)</sup> = 40.10 -0.20 L3 <sup>1)</sup> = 52.07 L4 = L5 = L6 = 64.14  <b>Hülsenboden</b> R = 1.24 R1 = 10.72 R3 = E = 3.19 E1 = 9.09 e min = 0.84 delta = 36° f = 0.38 beta = 35°  <b>Pulverkammer</b> P1 = 10.71 P2 <sup>1)*</sup> = 10.19 -0.20  <b>Schulterkonus</b> alpha* = 46° S* = 50.05 r1 min = 0.64 r2 = 2.54  <b>Hülsenhals</b> H1* = 8.45 H2 <sup>1)</sup> = 8.43  <b>Geschoss</b> G1 <sup>1)</sup> = 7.80 G2 = F = L3+G <sup>1)</sup> = 55.29  <b>Drücke (Energien)</b> <b>Mech. elektr. Wandler</b> Pmax = 2800 bar PK = 3220 bar PE = 3500 bar M = 25.00 EE = 2745 Joule  <b>Verschiedene Daten</b> Fe <sup>1)</sup> = 0.15 delta L =		<b>Längen</b> L1 = 38.01 L2 = 40.07 L3 <sup>1)</sup> = 52.20  <b>Stoßboden</b> R = R1 = 10.80 R2 = R3 = r =  <b>Pulverkammer</b> E = 3.19 P1 <sup>1)</sup> = 10.75 P2* = 10.22  <b>Schulterkonus</b> alpha <sup>1)*</sup> = 46° S* = 50.05 r1 max = 0.64 r2 = 2.54  <b>Hülsenhals</b> H1* = 8.47 H2 <sup>1)</sup> = 8.44  <b>Geschossübergang</b> G1 <sup>1)*</sup> = 7.80 G <sup>1)</sup> = 3.22 alpha1* = 60° h = 0.55 s = i <sup>1)*</sup> = 1°56' w =  <b>Lauf</b> F <sup>1)*</sup> = 7.62 Z <sup>1)</sup> = 7.77  <b>Züge</b> b = 2.67 N = 7 u = 305.00 Q = 47.04 mm <sup>2</sup>	
	Maßstab 1:1  Maße in << mm >> Maße und Toleranzen für Messläufe siehe Anhang CR 1.			
	Bemerkungen: 1) Kontrolle aus Sicherheitsgründen * Grundmaße			

<b>C.I.P.</b>	<b>30 TC</b>		<b>TAB.</b>	<b>I</b>
	Ursprungsland: US		Datum	09-05-05
			Revision	
	<b>PATRONE MAXI</b>		<b>PATRONENLAGER MINI</b>	
	<p><b>Längen</b></p> <p>L1 <sup>1)</sup> = 38.40 -0.20                      L2 <sup>1)</sup> = 41.19 -0.20                      L3 <sup>1)</sup> = 48.77                      L4 =                      L5 =                      L6 = 67.56</p> <p><b>Hülsenboden</b></p> <p>R = 1.37                      R1 = 12.01                      R3 =                      E = 3.88                      E1 = 10.39                      e min = 1.40                      δ = 35°                      f = 0.38                      β = 36°</p> <p><b>Pulverkammer</b></p> <p>P1 = 11.95                      P2 <sup>1)</sup>* = 11.78 -0.20</p> <p><b>Schulterkonus</b></p> <p>α * = 60°                      S * = 48.61                      r1 min = 1.93                      r2 = 3.17</p> <p><b>Hülsenhals</b></p> <p>H1 * = 8.56                      H2 <sup>1)</sup> = 8.56</p> <p><b>Geschoss</b></p> <p>G1 <sup>1)</sup> = 7.85                      G2 =                      F =                      L3+G <sup>1)</sup> = 58.42</p> <p><b>Drücke (Energien)</b></p> <p><b>Mech. elektr. Wandler</b></p> <p>Pmax = 4250 bar                      PK = 4888 bar                      PE = 5300 bar                      M = 25.00                      EE = 4000 Joule</p> <p><b>Verschiedene Daten</b></p> <p>Fe <sup>1)3)</sup> = 0.10                      delta L = 0.09</p>		<p><b>Längen</b></p> <p>L1 = 38.29                      L2 = 41.06                      L3 <sup>1)</sup> = 49.02</p> <p><b>Stoßboden</b></p> <p>R =                      R1 = 12.03                      R2 =                      R3 =                      r =</p> <p><b>Pulverkammer</b></p> <p>E = 3.88                      P1 <sup>1)</sup> = 12.03                      P2 * = 11.81</p> <p><b>Schulterkonus</b></p> <p>α <sup>1)</sup>* = 60°                      S * = 48.51                      r1 max = 0.76                      r2 = 3.17</p> <p><b>Hülsenhals</b></p> <p>H1 * = 8.61                      H2 <sup>1)</sup> = 8.58</p> <p><b>Geschossübergang</b></p> <p>G1 <sup>1)</sup>* = 7.84                      G <sup>1)</sup> = 9.65                      α1 = 90°                      h = 0.37                      s * = 5.45                      i <sup>1)</sup>* = 1°30'                      w =</p> <p><b>Lauf</b></p> <p>F <sup>1)</sup>* = 7.62                      Z <sup>1)</sup> = 7.82</p> <p><b>Züge</b></p> <p>b = 4.47                      N = 4                      u = 305.00                      Q = 47.51 mm<sup>2</sup></p>	
<p>Maßstab 1:1</p> <p>Maße in &lt;&lt; mm &gt;&gt;                      Maße und Toleranzen für Messläufe                      siehe Anhang CR 1.</p>		<p>Bemerkungen: 1) Kontrolle aus Sicherheitsgründen                      3) Verschlussabstand an Schulter                      * Grundmaße</p>		



<b>C.I.P.</b>	<b>30-06 Ackley Improved</b>	TAB.	I
		Datum	14-05-20
		Revision	
Ursprungsland: US			
	<b>PATRONE MAXI</b>		<b>PATRONENLAGER MINI</b>
	<b>Längen</b> L1 <sup>1)</sup> = 51.58 -0.20 L2 <sup>1)</sup> = 53.30 -0.20 L3 <sup>1)</sup> = 63.35 L4 = L5 = L6 = 84.84 <b>Hülsenboden</b> R = 1.24 R1 = 12.01 R3 = E = 3.16 E1 = 10.39 e min = 0.84 δ = 36° f = 0.38 β = 35° <b>Pulverkammer</b> P1 = 11.96 P2 <sup>1)</sup> * = 11.52 -0.20 <b>Schulterkonus</b> α * = 80° S * = 58.44 r1 min = r2 = <b>Hülsenhals</b> H1 * = 8.63 H2 <sup>1)</sup> = 8.63 <b>Geschoss</b> G1 <sup>1)</sup> * = 7.85 G2 = F = L3+G <sup>1)</sup> = 69.55 <b>Drücke (Energien)</b> <b>Mech. elektr. Wandler</b> Pmax = 4300 bar PK = 4945 bar PE = 5375 bar M = 25.00 EE = 4400 Joule <b>Verschiedene Daten</b> Fe <sup>1)3)</sup> = 0.10 delta L =	<b>Längen</b> L1 = 51.58 L2 = 53.28 L3 <sup>1)</sup> = 63.55 <b>Stoßboden</b> R = R1 = 12.04 R2 = R3 = r = <b>Pulverkammer</b> E = 3.16 P1 <sup>1)</sup> = 11.99 P2 * = 11.55 <b>Schulterkonus</b> α <sup>1)</sup> * = 80° S * = 58.46 r1 max = r2 = <b>Hülsenhals</b> H1 * = 8.70 H2 <sup>1)</sup> = 8.65 <b>Geschossübergang</b> G1 <sup>1)</sup> * = 7.89 G <sup>1)</sup> = 6.20 α1 = 70° h * = 0.54 s = i <sup>1)</sup> * = 1°22' w = <b>Lauf</b> F <sup>1)</sup> * = 7.62 Z <sup>1)</sup> = 7.82 <b>Züge</b> b = 4.49 N = 4 u = 254.00 Q = 47.52 mm <sup>2</sup>	
Maßstab 1:1.02			
Maße in << mm >> Maße und Toleranzen für Messläufe siehe Anhang CR1.	Bemerkungen: 1) Kontrolle aus Sicherheitsgründen 3) Verschlussabstand an Schulter * Grundmaße		



<b>C.I.P.</b>	<b>30-06 Spring.</b>	<b>TAB.</b>	<b>I</b>
		<b>Datum</b>	<b>84-06-14</b>
		<b>Revision</b>	<b>08-09-23</b>

Ursprungsland: US

Alternative Namen: 30-06 Springfield, 30-06, 7,62 x 63

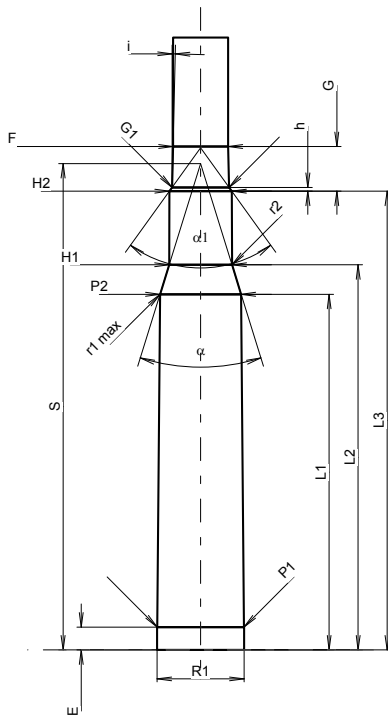
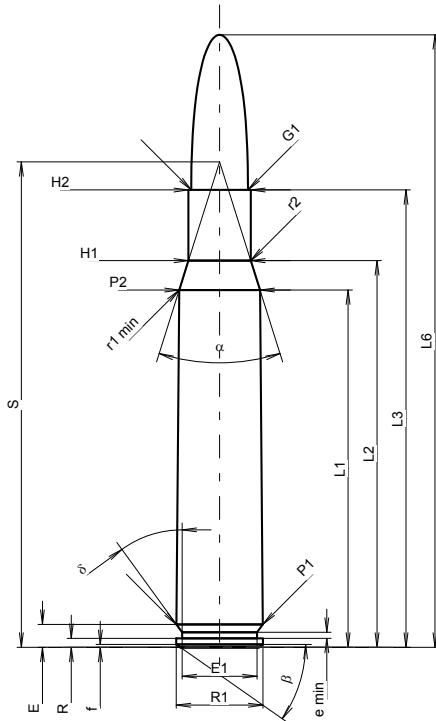

Maßstab 1:1.05

Maße in << mm >>  
Maße und Toleranzen für Messläufe  
siehe Anhang CR 1.

**PATRONE MAXI**

**Längen**

L1 1)	=	49.49	-0.20
L2 1)	=	53.56	-0.20
L3 1)	=	63.35	
L4	=		
L5	=		
L6	=	84.84	

**Hülsenboden**

R	=	1.24	
R1	=	12.01	
R3	=		
E	=	3.16	
E1	=	10.39	
e min	=	0.84	
delta	=	36°	
f	=	0.38	
beta	=	35°	

**Pulverkammer**

P1	=	11.96	
P2 1)*	=	11.20	-0.20

**Schulterkonus**

alpha*	=	35°	
S*	=	67.25	
r1 min	=	1.27	
r2	=	2.54	

**Hülsenhals**

H1*	=	8.63	
H2 1)	=	8.63	

**Geschoss**

G1 1)	=	7.85	
G2	=		
F	=		
L3+G 1)	=	69.54	

**Drücke (Energien)**

**Mech. elektr. Wandler**

Pmax	=	4050 bar	
PK	=	4658 bar	
PE	=	5060 bar	
M	=	25.00	
EE	=	4335 Joule	

**Verschiedene Daten**

Fe 1)3)	=	0.10	
delta L	=	0.16	

**PATRONENLAGER MINI**

**Längen**

L1	=	49.27	
L2	=	53.36	
L3 1)	=	63.55	

**Stoßboden**

R	=		
R1	=	12.04	
R2	=		
R3	=		
r	=		

**Pulverkammer**

E	=	3.16	
P1 1)	=	11.99	
P2*	=	11.24	

**Schulterkonus**

alpha 1)*	=	34°30'	
S*	=	67.37	
r1 max	=	1.27	
r2	=	3.05	

**Hülsenhals**

H1*	=	8.70	
H2 1)	=	8.65	

**Geschossübergang**

G1 1)*	=	7.89	
G 1)	=	6.19	
alpha 1*	=	71°25'48"	
h	=	0.53	
s	=		
i 1)*	=	1°22'	
w	=		

**Lauf**

F 1)*	=	7.62	
Z 1)	=	7.82	

**Züge**

b	=	4.49	
N	=	4	
u	=	254.00	
Q	=	47.55	mm <sup>2</sup>

Bemerkungen: 1) Kontrolle aus Sicherheitsgründen  
3) Verschlussabstand an Schulter  
\* Grundmaße

<b>C.I.P.</b>	<b>30-284 NOLASCO</b>	TAB.	I
		Datum	07-05-14
		Revision	09-05-05
Ursprungsland: FR			
	<b>PATRONE MAXI</b>	<b>PATRONENLAGER MINI</b>	
	<p><b>Längen</b></p> <p>L1 <sup>1)*</sup> = 44.98 -0.20                  L2 <sup>1)*</sup> = 47.36 -0.20                  L3 <sup>1)</sup> = 55.10                  L4 =                  L5 =                  L6 = 76.00</p> <p><b>Hülsenboden</b></p> <p>R = 1.02                  R1 = 12.01                  R3 =                  E = 3.78                  E1 = 10.39                  e min = 1.37                  delta = 40°                  f = 0.38                  beta = 35°</p> <p><b>Pulverkammer</b></p> <p>P1 = 12.72                  P2 <sup>1)*</sup> = 12.06 -0.20</p> <p><b>Schulterkonus</b></p> <p>alpha = 70°                  S = 53.59                  r1 min = 0.80                  r2 = 3.20</p> <p><b>Hülsenhals</b></p> <p>H1 * = 8.72                  H2 <sup>1)</sup> = 8.67</p> <p><b>Geschoss</b></p> <p>G1 <sup>1)</sup> = 7.85                  G2 =                  F =                  L3+G <sup>1)</sup> = 65.76</p> <p><b>Drücke (Energien)</b></p> <p><b>Mech. elektr. Wandler</b></p> <p>Pmax = 3800 bar                  PK = 4370 bar                  PE = 4750 bar                  M = 25.00                  EE = 2750 Joule</p> <p><b>Verschiedene Daten</b></p> <p>Fe <sup>1)3)</sup> = 0.15                  delta L =</p>	<p><b>Längen</b></p> <p>L1 * = 44.96                  L2 * = 47.34                  L3 <sup>1)</sup> = 55.30</p> <p><b>Stoßboden</b></p> <p>R =                  R1 = 12.04                  R2 =                  R3 =                  r =</p> <p><b>Pulverkammer</b></p> <p>E = 3.78                  P1 <sup>1)</sup> = 12.75                  P2 * = 12.09</p> <p><b>Schulterkonus</b></p> <p>alpha <sup>1)</sup> = 70°                  S = 53.59                  r1 max = 0.80                  r2 = 3.20</p> <p><b>Hülsenhals</b></p> <p>H1 * = 8.75                  H2 <sup>1)</sup> = 8.70</p> <p><b>Geschossübergang</b></p> <p>G1 <sup>1)*</sup> = 7.87                  G <sup>1)*</sup> = 10.66                  alpha l = 90°                  h = 0.42                  s * = 3.50                  i <sup>1)</sup> = 1°                  w =</p> <p><b>Lauf</b></p> <p>F <sup>1)*</sup> = 7.62                  Z <sup>1)</sup> = 7.82</p> <p><b>Züge</b></p> <p>b = 4.47                  N = 4                  u = 305.00                  Q = 47.51 mm<sup>2</sup></p>	
<p>Maßstab 1.05:1</p> <p style="text-align: center;">Maße in &lt;&lt; mm &gt;&gt; Maße und Toleranzen für Messläufe siehe Anhang CR 1.</p>		<p>Bemerkungen: 1) Kontrolle aus Sicherheitsgründen 3) Verschlussabstand an Schulter * Grundmaße</p>	

C.I.P.	30 - 284 Win.  Ursprungsland: US	TAB.	I
		Datum	98-02-09
		Revision	02-05-15
	<b>PATRONE MAXI</b>		
	<b>Längen</b> L1 <sup>1)</sup> = 44.98 -0.20 L2 <sup>1)</sup> = 47.36 -0.20 L3 <sup>1)</sup> = 55.10 L4 = L5 = L6 = 72.00  <b>Hülsenboden</b> R = 1.02 R1 = 12.01 R3 = E = 3.78 E1 = 10.39 e min = 1.37 delta = 40° f = 0.38 beta = 35°  <b>Pulverkammer</b> P1 = 12.72 P2 <sup>1)*</sup> = 12.06 -0.20  <b>Schulterkonus</b> alpha * = 70° S * = 53.59 r1 min = 0.80 r2 = 3.20  <b>Hülsenhals</b> H1 * = 8.72 H2 <sup>1)</sup> = 8.67  <b>Geschoss</b> G1 <sup>1)</sup> = 7.85 G2 = F <sup>1)</sup> = L3+G = 62.08  <b>Drücke (Energien)</b> <b>Mech. elektr. Wandler</b> Pmax = 3800 bar PK = 4370 bar PE = 4750 bar M = 25.00 EE = 4300 Joule  <b>Verschiedene Daten</b> Fe <sup>1)</sup> = 0.15 delta L =		
	<b>PATRONENLAGER MINI</b>		
	<b>Längen</b> L1 = 44.96 L2 = 47.34 L3 <sup>1)</sup> = 55.30  <b>Stoßboden</b> R = R1 = 12.04 R2 = R3 = r =  <b>Pulverkammer</b> E = 3.78 P1 <sup>1)</sup> = 12.75 P2 * = 12.09  <b>Schulterkonus</b> alpha <sup>1)*</sup> = 70° S * = 53.59 r1 max = 0.80 r2 = 3.20  <b>Hülsenhals</b> H1 * = 8.75 H2 <sup>1)</sup> = 8.70  <b>Geschossübergang</b> G1 <sup>1)*</sup> = 7.87 G <sup>1)</sup> = 6.98 alpha 1 = 90° h = 0.42 s * = 2.89 i <sup>1)*</sup> = 1°45' w =  <b>Lauf</b> F <sup>1)*</sup> = 7.62 Z <sup>1)</sup> = 7.82  <b>Züge</b> b = 4.47 N = 4 u = 305.00 Q = 47.51 mm <sup>2</sup>		
Maßstab 1:1			
Maße in << mm >> Maße und Toleranzen für Messläufe siehe Anhang CR 1.	Bemerkungen:		1) Kontrolle aus Sicherheitsgründen * Grundmaße

<b>C.I.P.</b>	<b>30-47 GS</b>		<b>TAB.</b>	<b>I</b>
	Ursprungsland: IT		Datum	14-05-20
			Revision	
	<b>PATRONE MAXI</b>		<b>PATRONENLAGER MINI</b>	
	<p><b>Längen</b></p> <p>L1 <sup>1)</sup> = 35.68 -0.20                  L2 <sup>1)</sup> = 38.50 -0.20                  L3 <sup>1)</sup> = 47.00                  L4 =                  L5 =                  L6 = 66.60</p> <p><b>Hülsenboden</b></p> <p>R = 1.37                  R1 = 12.01                  R3 =                  E = 3.84                  E1 = 10.39                  e min = 1.40                  delta = 36°                  f = 0.38                  beta = 45°</p> <p><b>Pulverkammer</b></p> <p>P1 = 11.95                  P2 <sup>1)</sup>* = 11.59 -0.20</p> <p><b>Schulterkonus</b></p> <p>alpha * = 60°03'26"                  S * = 45.71                  r1 min = 1.00                  r2 = 1.50</p> <p><b>Hülsenhals</b></p> <p>H1 * = 8.33                  H2 <sup>1)</sup> = 8.33</p> <p><b>Geschoss</b></p> <p>G1 <sup>1)</sup> = 7.82                  G2 =                  F =                  L3+G <sup>1)</sup> = 51.28</p> <p><b>Drücke (Energien)</b></p> <p><b>Mech. elektr. Wandler</b></p> <p>Pmax = 4350 bar                  PK = 5003 bar                  PE = 5438 bar                  M = 25.00                  EE = 4300 Joule</p> <p><b>Verschiedene Daten</b></p> <p>Fe <sup>1)3)</sup> = 0.10                  delta L = 0.08</p>		<p><b>Längen</b></p> <p>L1 = 35.57                  L2 = 38.38                  L3 <sup>1)</sup> = 47.26</p> <p><b>Stoßboden</b></p> <p>R =                  R1 = 12.04                  R2 =                  R3 =                  r =</p> <p><b>Pulverkammer</b></p> <p>E = 3.85                  P1 <sup>1)</sup> = 11.99                  P2 * = 11.63</p> <p><b>Schulterkonus</b></p> <p>alpha <sup>1)</sup>* = 60°04'51"                  S * = 45.63                  r1 max = 0.75                  r2 = 1.90</p> <p><b>Hülsenhals</b></p> <p>H1 * = 8.38                  H2 <sup>1)</sup> = 8.38</p> <p><b>Geschossübergang</b></p> <p>G1 <sup>1)</sup>* = 7.83                  G <sup>1)</sup> = 4.28                  alpha1 = 90°                  h * = 0.27                  s =                  i <sup>1)</sup>* = 1°30'                  w =</p> <p><b>Lauf</b></p> <p>F <sup>1)</sup>* = 7.62                  Z <sup>1)</sup> = 7.82</p> <p><b>Züge</b></p> <p>b = 2.50                  N = 6                  u = 355.60                  Q = 47.13 mm<sup>2</sup></p>	
<p>Maßstab 1.14:1</p> <p>Maße in &lt;&lt; mm &gt;&gt;                  Maße und Toleranzen für Messläufe                  siehe Anhang CR1.</p>		<p>Bemerkungen: 1) Kontrolle aus Sicherheitsgründen                  3) Verschlussabstand an Schulter                  * Grundmaße</p>		

<b>C.I.P.</b>	<b>300 AAC Blackout</b>	TAB.	I	
		Datum	15-05-19	
		Revision	16-05-18	
Ursprungsland: US				
Alternative Namen: 300 BLK				
	<b>PATRONE MAXI</b>		<b>PATRONENLAGER MINI</b>	
	<b>Längen</b> L1 <sup>1)</sup> = 27.20 -0.20 L2 <sup>1)</sup> = 28.00 -0.20 L3 <sup>1)</sup> = 34.75 L4 = L5 = L6 = 57.40		<b>Längen</b> L1 = 27.09 L2 = 27.83 L3 <sup>1)</sup> = 35.00	
	<b>Hülsenboden</b> R = 1.14 R1 = 9.60 R3 = E = 3.15 E1 = 8.43 e min = 0.76 delta = 25° f = 0.45 beta = 35°		<b>Stoßboden</b> R = R1 = 9.66 R2 = R3 = r =	
	<b>Pulverkammer</b> P1 = 9.60 P2 <sup>1)</sup> * = 9.16 -0.20		<b>Pulverkammer</b> E = 3.15 P1 <sup>1)</sup> = 9.62 P2 * = 9.19	
<b>Schulterkonus</b> alpha * = 46° S * = 37.99 r1 min = 1.27 r2 = 1.28		<b>Schulterkonus</b> alpha <sup>1)</sup> * = 46° S * = 37.91 r1 max = 1.27 r2 = 0.50		
<b>Hülsenhals</b> H1 * = 8.48 H2 <sup>1)</sup> = 8.48		<b>Hülsenhals</b> H1 * = 8.56 H2 <sup>1)</sup> = 8.51		
<b>Geschoss</b> G1 <sup>1)</sup> = 7.85 G2 = F = 7.62 L3+G <sup>1)</sup> = 43.89		<b>Geschossübergang</b> G1 <sup>1)</sup> * = 7.85 G <sup>1)</sup> = 9.14 alpha l = 90° h = 0.33 s * = 4.75 i <sup>1)</sup> * = 1°30' w =		
<b>Drücke (Energien)</b> <b>Mech. elektr. Wandler</b> Pmax = 3700 bar PK = 4255 bar PE = 4625 bar M = 17.50 EE = 2000 Joule		<b>Lauf</b> F <sup>1)</sup> * = 7.62 Z <sup>1)</sup> = 7.82		
<b>Verschiedene Daten</b> Fe <sup>1)3)</sup> = 0.15 delta L = 0.08		<b>Züge</b> b = 4.52 N = 4 u = 203.20 Q = 47.54 mm <sup>2</sup>		
Maßstab 1.37:1		<b>Bemerkungen:</b> 1) Kontrolle aus Sicherheitsgründen 3) Verschlussabstand an Schulter * Grundmaße		
Maße in << mm >> Maße und Toleranzen für Messläufe siehe Anhang CR1.				

<b>C.I.P.</b>	<b>300 Blacktornado</b>	<b>TAB.</b>	<b>I</b>
		<b>Datum</b>	<b>15-05-19</b>
		<b>Revision</b>	<b>16-05-18</b>
Ursprungsland: IT			
	<b>PATRONE MAXI</b>		<b>PATRONENLAGER MINI</b>
	<p><b>Längen</b></p> <p>L1 <sup>1)</sup> = 46.90 -0.20</p> <p>L2 <sup>1)</sup> = 50.30 -0.20</p> <p>L3 <sup>1)</sup> = 62.00</p> <p>L4 =</p> <p>L5 =</p> <p>L6 = 84.00</p> <p><b>Hülsenboden</b></p> <p>R = 1.52</p> <p>R1 = 14.85</p> <p>R3 =</p> <p>E = 3.10</p> <p>E1 = 13.24</p> <p>e min = 0.95</p> <p>delta = 50°</p> <p>f = 0.50</p> <p>beta = 45°</p> <p><b>Pulverkammer</b></p> <p>P1 = 14.74</p> <p>P2 <sup>1)</sup>* = 14.26 -0.20</p> <p><b>Schulterkonus</b></p> <p>alpha * = 80°</p> <p>S * = 55.41</p> <p>r1 min =</p> <p>r2 = 1.52</p> <p><b>Hülsenhals</b></p> <p>H1 * = 8.56</p> <p>H2 <sup>1)</sup> = 8.56</p> <p><b>Geschoss</b></p> <p>G1 = 7.83</p> <p>G2 =</p> <p>F =</p> <p>L3+G <sup>1)</sup> = 68.11</p> <p><b>Drücke (Energien)</b></p> <p><b>Mech. elektr. Wandler</b></p> <p>Pmax = 4400 bar</p> <p>PK = 5060 bar</p> <p>PE = 5500 bar</p> <p>M = 25.00</p> <p>EE = 5220 Joule</p> <p><b>Verschiedene Daten</b></p> <p>Fe <sup>1)3)</sup> = 0.10</p> <p>delta L =</p>	<p><b>Längen</b></p> <p>L1 = 46.99</p> <p>L2 = 50.38</p> <p>L3 <sup>1)</sup> = 62.23</p> <p><b>Stoßboden</b></p> <p>R =</p> <p>R1 = 14.90</p> <p>R2 =</p> <p>R3 =</p> <p>r =</p> <p><b>Pulverkammer</b></p> <p>E = 3.15</p> <p>P1 <sup>1)</sup> = 14.86</p> <p>P2 * = 14.30</p> <p><b>Schulterkonus</b></p> <p>alpha <sup>1)</sup>* = 80°</p> <p>S * = 55.51</p> <p>r1 max =</p> <p>r2 = 1.52</p> <p><b>Hülsenhals</b></p> <p>H1 * = 8.61</p> <p>H2 <sup>1)</sup> = 8.61</p> <p><b>Geschossübergang</b></p> <p>G1 <sup>1)</sup>* = 7.84</p> <p>G <sup>1)</sup> = 6.11</p> <p>alpha1 = 90°</p> <p>h = 0.39</p> <p>s * = 1.91</p> <p>i <sup>1)</sup>* = 1°30'</p> <p>w =</p> <p><b>Lauf</b></p> <p>F <sup>1)</sup>* = 7.62</p> <p>Z <sup>1)</sup> = 7.82</p> <p><b>Züge</b></p> <p>b = 4.47</p> <p>N = 4</p> <p>u = 229.00</p> <p>Q = 47.51 mm<sup>2</sup></p>	
<p>Maßstab 1:1.07</p> <p>Maße in &lt;&lt; mm &gt;&gt;</p> <p>Maße und Toleranzen für Messläufe siehe Anhang CR1.</p>	<p>Bemerkungen: 1) Kontrolle aus Sicherheitsgründen</p> <p>3) Verschlussabstand an Schulter</p> <p>* Grundmaße</p>		



<b>C.I.P.</b>	<b>300 Blaser Mag.</b>	TAB.	I
		Datum	09-05-05
		Revision	
Ursprungsland: SE			
	<b>PATRONE MAXI</b>	<b>PATRONENLAGER MINI</b>	
	<p><b>Längen</b></p> <p>L1 <sup>1)</sup> = 52.12 -0.20</p> <p>L2 <sup>1)</sup> = 55.92 -0.20</p> <p>L3 <sup>1)</sup> = 64.20</p> <p>L4 =</p> <p>L5 =</p> <p>L6 = 84.84</p> <p><b>Hülsenboden</b></p> <p>R = 1.37</p> <p>R1 = 13.59</p> <p>R3 =</p> <p>E = 3.61</p> <p>E1 = 12.19</p> <p>e min = 1.42</p> <p>delta = 45°</p> <p>f = 0.30</p> <p>beta = 35°</p> <p><b>Pulverkammer</b></p> <p>P1 = 13.84</p> <p>P2 <sup>1)</sup>* = 13.00 -0.20</p> <p><b>Schulterkonus</b></p> <p>alpha * = 60°</p> <p>S * = 63.38</p> <p>r1 min = 1.50</p> <p>r2 = 2.00</p> <p><b>Hülsenhals</b></p> <p>H1 * = 8.61</p> <p>H2 <sup>1)</sup> = 8.61</p> <p><b>Geschoss</b></p> <p>G1 <sup>1)</sup> = 7.83</p> <p>G2 =</p> <p>F =</p> <p>L3+G <sup>1)</sup> = 69.80</p> <p><b>Drücke (Energien)</b></p> <p><b>Mech. elektr. Wandler</b></p> <p>Pmax = 4200 bar</p> <p>PK = 4830 bar</p> <p>PE = 5250 bar</p> <p>M = 25.00</p> <p>EE = 5545 Joule</p> <p><b>Verschiedene Daten</b></p> <p>Fe <sup>1)3)</sup> = 0.10</p> <p>delta L =</p>	<p><b>Längen</b></p> <p>L1 = 52.10</p> <p>L2 = 55.87</p> <p>L3 <sup>1)</sup> = 64.50</p> <p><b>Stoßboden</b></p> <p>R = 1.37</p> <p>R1 = 13.92</p> <p>R2 =</p> <p>R3 =</p> <p>r =</p> <p><b>Pulverkammer</b></p> <p>E = 3.61</p> <p>P1 <sup>1)</sup> = 13.87</p> <p>P2 * = 13.03</p> <p><b>Schulterkonus</b></p> <p>alpha <sup>1)</sup>* = 60°</p> <p>S * = 63.38</p> <p>r1 max = 1.50</p> <p>r2 = 2.00</p> <p><b>Hülsenhals</b></p> <p>H1 * = 8.68</p> <p>H2 <sup>1)</sup> = 8.63</p> <p><b>Geschossübergang</b></p> <p>G1 <sup>1)</sup>* = 7.84</p> <p>G <sup>1)</sup> = 5.60</p> <p>alpha l = 90°</p> <p>h = 0.40</p> <p>s * = 2.00</p> <p>i <sup>1)</sup>* = 1°45'</p> <p>w =</p> <p><b>Lauf</b></p> <p>F <sup>1)</sup>* = 7.62</p> <p>Z <sup>1)</sup> = 7.82</p> <p><b>Züge</b></p> <p>b = 4.49</p> <p>N = 4</p> <p>u = 279.40</p> <p>Q = 47.52 mm<sup>2</sup></p>	
	<p><b>Hülsenhals</b></p> <p>H1 * = 8.61</p> <p>H2 <sup>1)</sup> = 8.61</p> <p><b>Geschoss</b></p> <p>G1 <sup>1)</sup> = 7.83</p> <p>G2 =</p> <p>F =</p> <p>L3+G <sup>1)</sup> = 69.80</p> <p><b>Drücke (Energien)</b></p> <p><b>Mech. elektr. Wandler</b></p> <p>Pmax = 4200 bar</p> <p>PK = 4830 bar</p> <p>PE = 5250 bar</p> <p>M = 25.00</p> <p>EE = 5545 Joule</p> <p><b>Verschiedene Daten</b></p> <p>Fe <sup>1)3)</sup> = 0.10</p> <p>delta L =</p>	<p><b>Längen</b></p> <p>L1 = 52.10</p> <p>L2 = 55.87</p> <p>L3 <sup>1)</sup> = 64.50</p> <p><b>Stoßboden</b></p> <p>R = 1.37</p> <p>R1 = 13.92</p> <p>R2 =</p> <p>R3 =</p> <p>r =</p> <p><b>Pulverkammer</b></p> <p>E = 3.61</p> <p>P1 <sup>1)</sup> = 13.87</p> <p>P2 * = 13.03</p> <p><b>Schulterkonus</b></p> <p>alpha <sup>1)</sup>* = 60°</p> <p>S * = 63.38</p> <p>r1 max = 1.50</p> <p>r2 = 2.00</p> <p><b>Hülsenhals</b></p> <p>H1 * = 8.68</p> <p>H2 <sup>1)</sup> = 8.63</p> <p><b>Geschossübergang</b></p> <p>G1 <sup>1)</sup>* = 7.84</p> <p>G <sup>1)</sup> = 5.60</p> <p>alpha l = 90°</p> <p>h = 0.40</p> <p>s * = 2.00</p> <p>i <sup>1)</sup>* = 1°45'</p> <p>w =</p> <p><b>Lauf</b></p> <p>F <sup>1)</sup>* = 7.62</p> <p>Z <sup>1)</sup> = 7.82</p> <p><b>Züge</b></p> <p>b = 4.49</p> <p>N = 4</p> <p>u = 279.40</p> <p>Q = 47.52 mm<sup>2</sup></p>	
Maßstab 1:1			
<p>Maße in &lt;&lt; mm &gt;&gt;</p> <p>Maße und Toleranzen für Messläufe siehe Anhang CR 1.</p>		<p>Bemerkungen: 1) Kontrolle aus Sicherheitsgründen</p> <p>3) Verschlussabstand an Schulter</p> <p>* Grundmaße</p>	

<b>C.I.P.</b>	<b>300 CR</b>		<b>TAB.</b>	<b>I</b>
	Ursprungsland: BE		<b>Datum</b>	<b>06-05-16</b>
			<b>Revision</b>	<b>08-04-15</b>
	<b>PATRONE MAXI</b>		<b>PATRONENLAGER MINI</b>	
	<p><b>Längen</b></p> <p>L1 <sup>1)</sup> = 39.59 -0.20                  L2 <sup>1)</sup> = 41.92 -0.20                  L3 <sup>1)</sup> = 51.06                  L4 =                  L5 =                  L6 = 71.00</p> <p><b>Hülsenboden</b></p> <p>R = 1.24                  R1 = 12.01                  R3 =                  E = 3.72                  E1 = 10.39                  e min = 1.40                  delta = 36°                  f = 0.26                  beta = 35°</p> <p><b>Pulverkammer</b></p> <p>P1 = 11.96                  P2 <sup>1)</sup>* = 11.34 -0.20</p> <p><b>Schulterkonus</b></p> <p>alpha * = 60°                  S * = 49.41                  r1 min = 0.74                  r2 = 3.18</p> <p><b>Hülsenhals</b></p> <p>H1 * = 8.65                  H2 <sup>1)</sup> = 8.61</p> <p><b>Geschoss</b></p> <p>G1 <sup>1)</sup> = 7.85                  G2 =                  F =                  L3+G <sup>1)</sup> = 59.64</p> <p><b>Drücke (Energien)</b></p> <p><b>Mech. elektr. Wandler</b></p> <p>Pmax = 4300 bar                  PK = 4945 bar                  PE = 5375 bar                  M = 25.00                  EE = 3675 Joule</p> <p><b>Verschiedene Daten</b></p> <p>Fe <sup>1)3)</sup> = 0.10                  delta L =</p>		<p><b>Längen</b></p> <p>L1 = 39.57                  L2 = 41.88                  L3 <sup>1)</sup> = 51.32</p> <p><b>Stoßboden</b></p> <p>R =                  R1 = 12.03                  R2 =                  R3 =                  r =</p> <p><b>Pulverkammer</b></p> <p>E = 3.72                  P1 <sup>1)</sup> = 12.00                  P2 * = 11.36</p> <p><b>Schulterkonus</b></p> <p>alpha <sup>1)</sup>* = 60°                  S * = 49.41                  r1 max = 0.76                  r2 = 3.18</p> <p><b>Hülsenhals</b></p> <p>H1 * = 8.69                  H2 <sup>1)</sup> = 8.64</p> <p><b>Geschossübergang</b></p> <p>G1 <sup>1)</sup>* = 7.85                  G <sup>1)</sup> = 8.58                  alpha1 * = 90°                  h = 0.39                  s = 4.85                  i <sup>1)</sup>* = 1°45'                  w =</p> <p><b>Lauf</b></p> <p>F <sup>1)</sup>* = 7.62                  Z <sup>1)</sup> = 7.82</p> <p><b>Züge</b></p> <p>b = 2.41                  N = 6                  u = 305.00                  Q = 47.07 mm<sup>2</sup></p>	
Maßstab 1:1  Maße in << mm >> Maße und Toleranzen für Messläufe siehe Anhang CR 1.		Bemerkungen: 1) Kontrolle aus Sicherheitsgründen 3) Verschlussabstand an Schulter * Grundmaße		

C.I.P.	300 Lapua Mag.	TAB.	I	
		Datum	89-10-06	
		Revision	08-09-23	
Ursprungsland: FI				
	<b>PATRONE MAXI</b> <b>Längen</b> L1 <sup>1)</sup> * = 54.90 -0.20 L2 <sup>1)</sup> * = 60.31 -0.20 L3 <sup>1)</sup> = 69.20 L4 = L5 = L6 = 94.50 <b>Hülsenboden</b> R = 1.52 R1 = 14.93 R3 = E = 3.12 E1 = 13.24 e min = 0.90 delta = 50° f = beta = 45° <b>Pulverkammer</b> P1 = 14.91 P2 <sup>1)</sup> * = 13.82 -0.20 <b>Schulterkonus</b> alpha = 49°57'9" S = 69.73 r1 min = r2 = <b>Hülsenhals</b> H1 * = 8.78 H2 <sup>1)</sup> = 8.73 <b>Geschoss</b> G1 <sup>1)</sup> = 7.87 G2 = F = L3+G <sup>1)</sup> = 75.70 <b>Drücke (Energien)</b> <b>Mech. elektr. Wandler</b> Pmax = 4400 bar PK = 5060 bar PE = 5500 bar M = 25.00 EE = 5220 Joule <b>Verschiedene Daten</b> Fe <sup>1)3)</sup> = 0.10 delta L = 0.07		<b>PATRONENLAGER MINI</b> <b>Längen</b> L1 * = 54.81 L2 * = 60.19 L3 <sup>1)</sup> = 69.45 <b>Stoßboden</b> R = R1 = 15.03 R2 = R3 = r = <b>Pulverkammer</b> E = 3.12 P1 <sup>1)</sup> = 14.96 P2 * = 13.85 <b>Schulterkonus</b> alpha <sup>1)</sup> = 50°01'18" S = 69.65 r1 max = r2 = <b>Hülsenhals</b> H1 * = 8.83 H2 <sup>1)</sup> = 8.77 <b>Geschossübergang</b> G1 <sup>1)</sup> * = 7.87 G <sup>1)</sup> * = 6.50 alpha l = 90° h = 0.45 s * = 3.00 i <sup>1)</sup> = 2°02'43" w = <b>Lauf</b> F <sup>1)</sup> * = 7.62 Z <sup>1)</sup> = 7.82 <b>Züge</b> b = 4.47 N = 4 u = 240.00 Q = 47.51 mm <sup>2</sup>	
Maßstab 1:1.15				
Maße in << mm >> Maße und Toleranzen für Messläufe siehe Anhang CR 1.		Bemerkungen: 1) Kontrolle aus Sicherheitsgründen 3) Verschlussabstand an Schulter * Grundmaße		

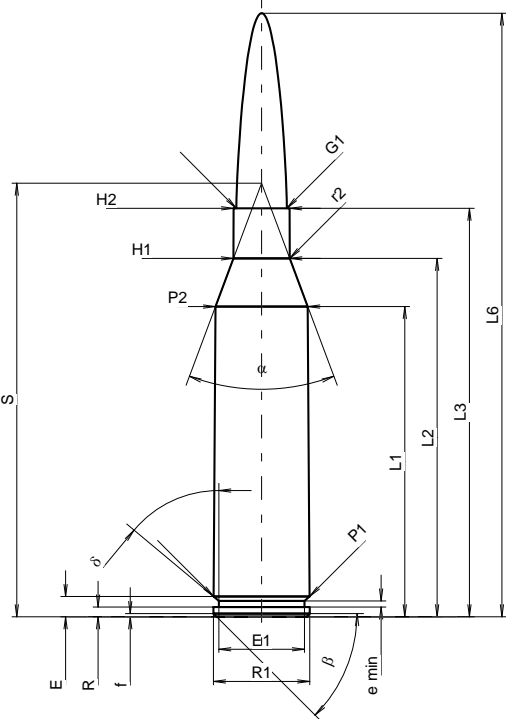
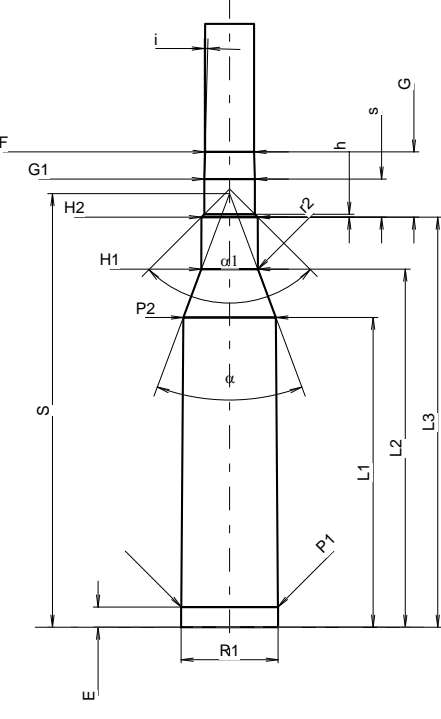
<b>C.I.P.</b>	<b>300 Norma Mag</b> Ursprungsland: SE	<b>TAB. I</b>
		<b>Datum 12-05-30</b>
		<b>Revision</b>
	<p style="text-align: center;"><b>PATRONE MAXI</b></p> <p><b>Längen</b></p> <p>L1 <sup>1)</sup> = 48.06 -0.20                  L2 <sup>1)</sup> = 55.52 -0.20                  L3 <sup>1)</sup> = 63.30                  L4 =                  L5 =                  L6 = 93.50</p> <p><b>Hülsenboden</b></p> <p>R = 1.52                  R1 = 14.93                  R3 =                  E = 3.15                  E1 = 13.24                  e min = 0.95                  delta = 50°                  f = 0.50                  beta = 45°</p> <p><b>Pulverkammer</b></p> <p>P1 = 14.87                  P2 <sup>1)</sup>* = 14.29 -0.20</p> <p><b>Schulterkonus</b></p> <p>alpha * = 41°                  S * = 67.17                  r1 min =                  r2 = 2.50</p> <p><b>Hülsenhals</b></p> <p>H1 * = 8.71                  H2 <sup>1)</sup> = 8.68</p> <p><b>Geschoss</b></p> <p>G1 <sup>1)</sup> = 7.83                  G2 =                  F =                  L3+G <sup>1)</sup> = 73.39</p> <p><b>Drücke (Energien)</b></p> <p><b>Mech. elektr. Wandler</b></p> <p>Pmax = 4400 bar                  PK = 5060 bar                  PE = 5500 bar                  M = 25.00                  EE = 5485 Joule</p> <p><b>Verschiedene Daten</b></p> <p>Fe <sup>1)3)</sup> = 0.10                  delta L =</p>	<p style="text-align: center;"><b>PATRONENLAGER MINI</b></p> <p><b>Längen</b></p> <p>L1 = 48.01                  L2 = 55.49                  L3 <sup>1)</sup> = 63.55</p> <p><b>Stoßboden</b></p> <p>R =                  R1 = 15.03                  R2 =                  R3 =                  r =</p> <p><b>Pulverkammer</b></p> <p>E = 3.15                  P1 <sup>1)</sup> = 14.94                  P2 * = 14.33</p> <p><b>Schulterkonus</b></p> <p>alpha <sup>1)*)</sup> = 41°                  S * = 67.17                  r1 max =                  r2 = 2.41</p> <p><b>Hülsenhals</b></p> <p>H1 * = 8.74                  H2 <sup>1)</sup> = 8.71</p> <p><b>Geschossübergang</b></p> <p>G1 <sup>1)*)</sup> = 7.84                  G <sup>1)</sup> = 10.09                  alpha l = 90°                  h = 0.44                  s * = 5.89                  i <sup>1)*)</sup> = 1°30'                  w =</p> <p><b>Lauf</b></p> <p>F <sup>1)*)</sup> = 7.62                  Z <sup>1)</sup> = 7.82</p> <p><b>Züge</b></p> <p>b = 4.47                  N = 4                  u = 229.00                  Q = 47.51 mm<sup>2</sup></p>
	 <p>Maßstab 1:1.17</p>	
<p style="text-align: center;">Maße in &lt;&lt; mm &gt;&gt; Maße und Toleranzen für Messläufe siehe Anhang CR1.</p>		<p>Bemerkungen: 1) Kontrolle aus Sicherheitsgründen                  3) Verschlussabstand an Schulter                  * Grundmaße</p>

C.I.P.	300 Pegasus	TAB.	I
		Datum	14-05-20
		Revision	
Ursprungsland: US			
	<b>PATRONE MAXI</b>		<b>PATRONENLAGER MINI</b>
	<p><b>Längen</b></p> <p>L1 <sup>1)</sup> = 62.23 -0.20                  L2 <sup>1)</sup> = 67.66 -0.20                  L3 <sup>1)</sup> = 75.95                  L4 =                  L5 =                  L6 = 95.25</p> <p><b>Hülsenboden</b></p> <p>R = 1.65                  R1 = 14.73                  R3 =                  E = 3.79                  E1 = 12.70                  e min = 1.12                  delta = 45°                  f = 0.25                  beta = 45°</p> <p><b>Pulverkammer</b></p> <p>P1 = 14.73                  P2 <sup>1)</sup>* = 14.38 -0.20</p> <p><b>Schulterkonus</b></p> <p>alpha * = 56°                  S * = 75.75                  r1 min = 1.02                  r2 = 3.18</p> <p><b>Hülsenhals</b></p> <p>H1 * = 8.61                  H2 <sup>1)</sup> = 8.59</p> <p><b>Geschoss</b></p> <p>G1 <sup>1)</sup>* = 7.82                  G2 =                  F =                  L3+G <sup>1)</sup> = 87.65</p> <p><b>Drücke (Energien)</b></p> <p><b>Mech. elektr. Wandler</b></p> <p>Pmax = 4300 bar                  PK = 4945 bar                  PE = 5375 bar                  M = 25.00                  EE = 6400 Joule</p> <p><b>Verschiedene Daten</b></p> <p>Fe <sup>1)3)</sup> = 0.10                  delta L =</p>		<p><b>Längen</b></p> <p>L1 = 62.20                  L2 = 67.61                  L3 <sup>1)</sup> = 76.20</p> <p><b>Stoßboden</b></p> <p>R =                  R1 = 14.78                  R2 =                  R3 =                  r =</p> <p><b>Pulverkammer</b></p> <p>E = 3.85                  P1 <sup>1)</sup> = 14.76                  P2 * = 14.41</p> <p><b>Schulterkonus</b></p> <p>alpha <sup>1)</sup>* = 56°                  S * = 75.75                  r1 max = 0.76                  r2 = 3.81</p> <p><b>Hülsenhals</b></p> <p>H1 * = 8.66                  H2 <sup>1)</sup> = 8.64</p> <p><b>Geschossübergang</b></p> <p>G1 <sup>1)</sup>* = 7.85                  G <sup>1)</sup> = 11.70                  alpha 1 = 90°                  h = 0.40                  s * = 5.72                  i <sup>1)</sup>* = 1°06'                  w =</p> <p><b>Lauf</b></p> <p>F <sup>1)</sup>* = 7.62                  Z <sup>1)</sup> = 7.82</p> <p><b>Züge</b></p> <p>b = 3.00                  N = 6                  u = 254.00                  Q = 47.45 mm<sup>2</sup></p>
	<p>Maßstab 1:1.25</p> <p>Maße in &lt;&lt; mm &gt;&gt;                  Maße und Toleranzen für Messläufe                  siehe Anhang CR1.</p>		<p>Bemerkungen: 1) Kontrolle aus Sicherheitsgründen                  3) Verschlussabstand an Schulter                  * Grundmaße</p>

C.I.P.	300 RCM Ursprungsland: US	TAB.	I
		Datum	10-05-26
		Revision	11-05-25
	<p><b>PATRONE MAXI</b></p> <p><b>Längen</b></p> <p>L1 <sup>1)</sup> = 41.74 -0.20                      L2 <sup>1)</sup> = 45.58 -0.20                      L3 <sup>1)</sup> = 53.34                      L4 =                      L5 =                      L6 = 72.14</p> <p><b>Hülsenboden</b></p> <p>R = 1.27                      R1 = 13.51                      R3 =                      E = 3.27                      E1 = 12.07                      e min = 0.94                      delta = 35°                      f = 0.41                      beta = 35°</p> <p><b>Pulverkammer</b></p> <p>P1 = 13.55                      P2 <sup>1)</sup>* = 13.08 -0.20</p> <p><b>Schulterkonus</b></p> <p>alpha * = 60°                      S * = 53.06                      r1 min = 1.27                      r2 = 3.18</p> <p><b>Hülsenhals</b></p> <p>H1 * = 8.64                      H2 <sup>1)</sup> = 8.64</p> <p><b>Geschoss</b></p> <p>G1 <sup>1)</sup>* = 7.85                      G2 =                      F =                      L3+G <sup>1)</sup> = 61.29</p> <p><b>Drücke (Energien)</b></p> <p><b>Mech. elektr. Wandler</b></p> <p>Pmax = 4400 bar                      PK = 5060 bar                      PE = 5500 bar                      M = 25.00                      EE = 4900 Joule</p> <p><b>Verschiedene Daten</b></p> <p>Fe <sup>1)3)</sup> = 0.10                      delta L = 0.10</p>	<p><b>PATRONENLAGER MINI</b></p> <p><b>Längen</b></p> <p>L1 = 41.61                      L2 = 45.44                      L3 <sup>1)</sup> = 53.59</p> <p><b>Stoßboden</b></p> <p>R =                      R1 = 13.62                      R2 =                      R3 =                      r =</p> <p><b>Pulverkammer</b></p> <p>E = 3.27                      P1 <sup>1)</sup> = 13.62                      P2 * = 13.11</p> <p><b>Schulterkonus</b></p> <p>alpha <sup>1)</sup>* = 60°                      S * = 52.97                      r1 max = 0.76                      r2 = 3.18</p> <p><b>Hülsenhals</b></p> <p>H1 * = 8.69                      H2 <sup>1)</sup> = 8.66</p> <p><b>Geschossübergang</b></p> <p>G1 <sup>1)</sup>* = 7.85                      G <sup>1)</sup> = 7.95                      alpha l = 90°                      h = 0.41                      s = 3.56                      i <sup>1)</sup>* = 1°30'                      w =</p> <p><b>Lauf</b></p> <p>F <sup>1)</sup>* = 7.62                      Z <sup>1)</sup> = 7.82</p> <p><b>Züge</b></p> <p>b = 2.79                      N = 6                      u = 254.00                      Q = 47.32 mm<sup>2</sup></p>	
			<p>Maßstab 1.04:1</p> <p>Maße in &lt;&lt; mm &gt;&gt; Maße und Toleranzen für Messläufe siehe Anhang CR 1.</p>

<b>C.I.P.</b>	<b>300 Rem. SA Ultra Mag.</b>	TAB. <b>I</b>
		Datum <b>02-03-01</b>
		Revision <b>04-09-27</b>
Ursprungsland: US		
	<b>PATRONE MAXI</b>	<b>PATRONENLAGER MINI</b>
	<p><b>Längen</b></p> <p>L1<sup>1)</sup> = 39.07 -0.20                  L2<sup>1)</sup> = 43.26 -0.20                  L3<sup>1)</sup> = 51.18                  L4 =                  L5 =                  L6 = 71.76</p> <p><b>Hülsenboden</b></p> <p>R = 1.27                  R1 = 13.56                  R3 =                  E = 3.75                  E1 = 12.07                  e min = 0.94                  delta = 32°                  f = 0.41                  beta = 35°</p> <p><b>Pulverkammer</b></p> <p>P1 = 14.00                  P2<sup>1)*</sup> = 13.58 -0.20</p> <p><b>Schulterkonus</b></p> <p>alpha* = 60°                  S* = 50.83                  r1 min =                  r2 = 3.18</p> <p><b>Hülsenhals</b></p> <p>H1* = 8.74                  H2<sup>1)</sup> = 8.74</p> <p><b>Geschoss</b></p> <p>G1<sup>1)</sup> = 7.85                  G2 =                  F =                  L3+G<sup>1)</sup> = 61.02</p> <p><b>Drücke (Energien)</b></p> <p><b>Mech. elektr. Wandler</b></p> <p>Pmax = 4400 bar                  PK = 5060 bar                  PE = 5500 bar                  M = 25.00                  EE = 5100 Joule</p> <p><b>Verschiedene Daten</b></p> <p>Fe = 0.10                  delta L =</p>	<p><b>Längen</b></p> <p>L1 = 38.95                  L2 = 43.12                  L3<sup>1)</sup> = 51.44</p> <p><b>Stoßboden</b></p> <p>R =                  R1 = 14.05                  R2 =                  R3 =                  r =</p> <p><b>Pulverkammer</b></p> <p>E = 3.75                  P1<sup>1)</sup> = 14.01                  P2* = 13.61</p> <p><b>Schulterkonus</b></p> <p>alpha<sup>1)*</sup> = 60°                  S* = 50.74                  r1 max =                  r2 = 3.18</p> <p><b>Hülsenhals</b></p> <p>H1* = 8.79                  H2<sup>1)</sup> = 8.76</p> <p><b>Geschossübergang</b></p> <p>G1<sup>1)*</sup> = 7.85                  G<sup>1)</sup> = 9.84                  alpha1* = 90°37'59"                  h = 0.46                  s = 3.25                  i<sup>1)*</sup> = 1°                  w =</p> <p><b>Lauf</b></p> <p>F<sup>1)*</sup> = 7.62                  Z<sup>1)</sup> = 7.82</p> <p><b>Züge</b></p> <p>b = 2.79                  N = 6                  u = 254.00                  Q = 47.32 mm<sup>2</sup></p>
Maßstab 1:1		
Maße in << mm >> Maße und Toleranzen für Messläufe siehe Anhang CR 1.		Bemerkungen: 1) Kontrolle aus Sicherheitsgründen * Grundmaße

<b>C.I.P.</b>	<b>300 Rem. Ultra Mag.</b>	TAB.	I
		Datum	98-11-03
		Revision	08-09-23
Ursprungsland: US			
	<b>PATRONE MAXI</b>	<b>PATRONENLAGER MINI</b>	
	<p><b>Längen</b></p> <p>L1 <sup>1)</sup> = 60.64 -0.20                  L2 <sup>1)</sup> = 64.62 -0.20                  L3 <sup>1)</sup> = 72.39                  L4 =                  L5 =                  L6 = 91.44</p> <p><b>Hülsenboden</b></p> <p>R = 1.27                  R1 = 13.56                  R3 =                  E = 3.75                  E1 = 12.07                  e min = 0.94                  delta = 32°                  f =                  beta = 35°</p> <p><b>Pulverkammer</b></p> <p>P1 = 13.97                  P2 <sup>1)</sup>* = 13.34 -0.20</p> <p><b>Schulterkonus</b></p> <p>alpha * = 60°                  S * = 72.19                  r1 min =                  r2 = 3.17</p> <p><b>Hülsenhals</b></p> <p>H1 * = 8.74                  H2 <sup>1)</sup> = 8.74</p> <p><b>Geschoss</b></p> <p>G1 <sup>1)</sup> = 7.85                  G2 =                  F =                  L3+G <sup>1)</sup> = 82.23</p> <p><b>Drücke (Energien)</b></p> <p><b>Mech. elektr. Wandler</b></p> <p>Pmax = 4400 bar                  PK = 5060 bar                  PE = 5500 bar                  M = 25.00                  EE = 5985 Joule</p> <p><b>Verschiedene Daten</b></p> <p>Fe <sup>1)3)</sup> = 0.10                  delta L = 0.11</p>	<p><b>Längen</b></p> <p>L1 = 60.51                  L2 = 64.47                  L3 <sup>1)</sup> = 72.64</p> <p><b>Stoßboden</b></p> <p>R =                  R1 = 14.05                  R2 =                  R3 =                  r =</p> <p><b>Pulverkammer</b></p> <p>E = 3.75                  P1 <sup>1)</sup> = 14.02                  P2 * = 13.36</p> <p><b>Schulterkonus</b></p> <p>alpha <sup>1)</sup>* = 60°                  S * = 72.08                  r1 max = 0.78                  r2 = 3.18</p> <p><b>Hülsenhals</b></p> <p>H1 * = 8.79                  H2 <sup>1)</sup> = 8.76</p> <p><b>Geschossübergang</b></p> <p>G1 <sup>1)</sup>* = 7.85                  G <sup>1)</sup> = 9.84                  alpha1 * = 90°                  h = 0.46                  s = 3.25                  i <sup>1)</sup>* = 1°                  w =</p> <p><b>Lauf</b></p> <p>F <sup>1)</sup>* = 7.62                  Z <sup>1)</sup> = 7.82</p> <p><b>Züge</b></p> <p>b = 2.92                  N = 6                  u = 254.00                  Q = 47.40 mm<sup>2</sup></p>	
Maßstab 1:1.15			
Maße in << mm >> Maße und Toleranzen für Messläufe siehe Anhang CR 1.		Bemerkungen: 1) Kontrolle aus Sicherheitsgründen 3) Verschlussabstand an Schulter * Grundmaße	

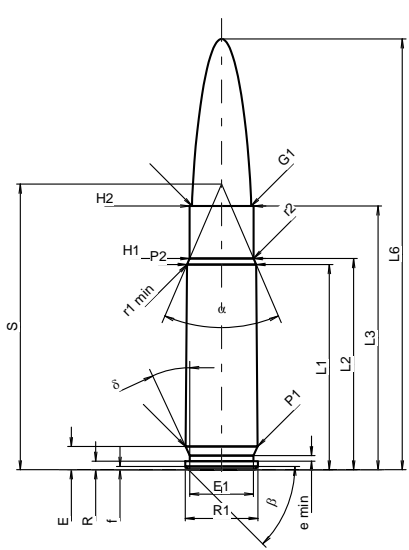
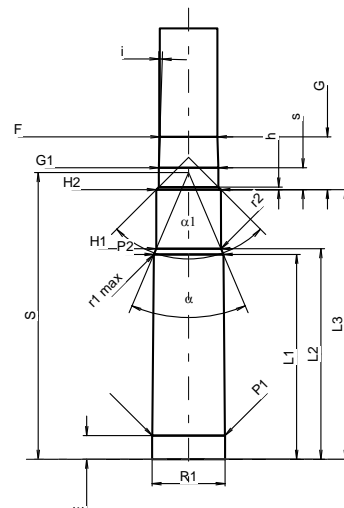

C.I.P.	300 Savage	TAB.	I
		Datum	84-06-14
		Revision	02-05-15
Ursprungsland: US			
	<b>PATRONE MAXI</b>		<b>PATRONENLAGER MINI</b>
	<p><b>Längen</b></p> <p>L1<sup>1)</sup> = 39.59 -0.20                  L2<sup>1)</sup> = 41.92 -0.20                  L3<sup>1)</sup> = 47.52                  L4 =                  L5 =                  L6 = 66.04</p> <p><b>Hülsenboden</b></p> <p>R = 1.24                  R1 = 12.01                  R3 =                  E = 3.18                  E1 = 10.39                  e min = 0.84                  delta = 36°                  f = 0.38                  beta = 35°</p> <p><b>Pulverkammer</b></p> <p>P1 = 11.99                  P2<sup>1)*</sup> = 11.34 -0.20</p> <p><b>Schulterkonus</b></p> <p>alpha* = 60°                  S* = 49.41                  r1 min = 0.76                  r2 = 3.18</p> <p><b>Hülsenhals</b></p> <p>H1* = 8.65                  H2<sup>1)</sup> = 8.61</p> <p><b>Geschoss</b></p> <p>G1<sup>1)</sup> = 7.85                  G2 =                  F =                  L3+G<sup>1)</sup> = 56.10</p> <p><b>Drücke (Energien)</b></p> <p><b>Mech. elektr. Wandler</b></p> <p>Pmax = 3650 bar                  PK = 4198 bar                  PE = 4560 bar                  M = 25.00                  EE = 3525 Joule</p> <p><b>Verschiedene Daten</b></p> <p>Fe<sup>1)</sup> = 0.15                  delta L =</p>		<p><b>Längen</b></p> <p>L1 = 39.57                  L2 = 41.88                  L3<sup>1)</sup> = 47.85</p> <p><b>Stoßboden</b></p> <p>R =                  R1 = 12.07                  R2 =                  R3 =                  r =</p> <p><b>Pulverkammer</b></p> <p>E = 3.18                  P1<sup>1)</sup> = 12.02                  P2* = 11.36</p> <p><b>Schulterkonus</b></p> <p>alpha<sup>1)*</sup> = 60°                  S* = 49.41                  r1 max = 0.76                  r2 = 3.18</p> <p><b>Hülsenhals</b></p> <p>H1* = 8.69                  H2<sup>1)</sup> = 8.64</p> <p><b>Geschossübergang</b></p> <p>G1<sup>1)*</sup> = 7.86                  G<sup>1)</sup> = 8.58                  alpha1* = 90°                  h = 0.39                  s = 4.85                  i<sup>1)*</sup> = 1°43'                  w =</p> <p><b>Lauf</b></p> <p>F<sup>1)*</sup> = 7.62                  Z<sup>1)</sup> = 7.82</p> <p><b>Züge</b></p> <p>b = 2.41                  N = 6                  u = 305.00                  Q = 47.10 mm<sup>2</sup></p>
	<p>Maßstab 1:1</p> <p>Maße in &lt;&lt; mm &gt;&gt;                  Maße und Toleranzen für Messläufe                  siehe Anhang CR 1.</p>		<p>Bemerkungen: 1) Kontrolle aus Sicherheitsgründen                  * Grundmaße</p>

<b>C.I.P.</b>	<b>300 Whisper</b>	<b>TAB.</b>	<b>I</b>
		<b>Datum</b>	<b>09-05-05</b>
		<b>Revision</b>	<b>15-05-19</b>
Ursprungsland: US			
	<b>PATRONE MAXI</b>	<b>PATRONENLAGER MINI</b>	
	<p><b>Längen</b></p> <p>L1 <sup>1)</sup> = 27.15 -0.20</p> <p>L2 <sup>1)</sup> = 27.94 -0.20</p> <p>L3 <sup>1)</sup> = 34.90</p> <p>L4 =</p> <p>L5 =</p> <p>L6 = 57.00</p> <p><b>Hülsenboden</b></p> <p>R = 1.14</p> <p>R1 = 9.60</p> <p>R3 =</p> <p>E = 3.07</p> <p>E1 = 8.43</p> <p>e min = 0.74</p> <p>δ = 25°</p> <p>f = 0.45</p> <p>β = 45°</p> <p><b>Pulverkammer</b></p> <p>P1 = 9.54</p> <p>P2 <sup>1)</sup>* = 9.14 -0.20</p> <p><b>Schulterkonus</b></p> <p>α * = 46°30'</p> <p>S * = 37.78</p> <p>r1 min = 0.80</p> <p>r2 = 0.80</p> <p><b>Hülsenhals</b></p> <p>H1 * = 8.46</p> <p>H2 <sup>1)</sup> = 8.46</p> <p><b>Geschoss</b></p> <p>G1 <sup>1)</sup> = 7.84</p> <p>G2 =</p> <p>F =</p> <p>L3+G <sup>1)</sup> = 41.88</p> <p><b>Drücke (Energien)</b></p> <p><b>Mech. elektr. Wandler</b></p> <p>Pmax = 3700 bar</p> <p>PK = 4255 bar</p> <p>PE = 4625 bar</p> <p>M = 17.50</p> <p>EE = 1100 Joule</p> <p><b>Verschiedene Daten</b></p> <p>Fe <sup>1)3)</sup> = 0.15</p> <p>delta L =</p>	<p><b>Längen</b></p> <p>L1 = 27.10</p> <p>L2 = 27.85</p> <p>L3 <sup>1)</sup> = 35.67</p> <p><b>Stoßboden</b></p> <p>R =</p> <p>R1 = 9.66</p> <p>R2 =</p> <p>R3 =</p> <p>r =</p> <p><b>Pulverkammer</b></p> <p>E = 3.13</p> <p>P1 <sup>1)</sup> = 9.61</p> <p>P2 * = 9.20</p> <p><b>Schulterkonus</b></p> <p>α <sup>1)</sup>* = 46°</p> <p>S * = 37.93</p> <p>r1 max = 0.50</p> <p>r2 = 0.50</p> <p><b>Hülsenhals</b></p> <p>H1 * = 8.56</p> <p>H2 <sup>1)</sup> = 8.54</p> <p><b>Geschossübergang</b></p> <p>G1 <sup>1)</sup>* = 7.87</p> <p>G <sup>1)</sup> = 6.98</p> <p>α1 = 90°</p> <p>h = 0.34</p> <p>s * = 2.89</p> <p>i <sup>1)</sup>* = 1°45'</p> <p>w =</p> <p><b>Lauf</b></p> <p>F <sup>1)</sup>* = 7.62</p> <p>Z <sup>1)</sup> = 7.82</p> <p><b>Züge</b></p> <p>b = 2.20</p> <p>N = 8</p> <p>u * = 203.00</p> <p>Q = 47.39 mm<sup>2</sup></p>	
			
Maßstab 1:1			
<p>Maße in &lt;&lt; mm &gt;&gt;</p> <p>Maße und Toleranzen für Messläufe siehe Anhang CR 1.</p>	<p>Bemerkungen: 1) Kontrolle aus Sicherheitsgründen 3) Verschlussabstand an Schulter * Grundmaße</p>		

<b>C.I.P.</b>	<b>300 Win. Short Mag.</b>	TAB.	I
		Datum	02-01-22
		Revision	08-09-23
Ursprungsland: US			
	<b>PATRONE MAXI</b>	<b>PATRONENLAGER MINI</b>	
	<p><b>Längen</b></p> <p>L1 <sup>1)</sup> = 42.25 -0.20                  L2 <sup>1)</sup> = 45.77 -0.20                  L3 <sup>1)</sup> = 53.34                  L4 =                  L5 =                  L6 = 72.64</p> <p><b>Hülsenboden</b></p> <p>R = 1.37                  R1 = 13.59                  R3 =                  E = 3.35                  E1 = 12.19                  e min = 1.02                  delta = 45°                  f = 0.36                  beta = 35°</p> <p><b>Pulverkammer</b></p> <p>P1 = 14.12                  P2 <sup>1)</sup>* = 13.67 -0.20</p> <p><b>Schulterkonus</b></p> <p>alpha * = 70°                  S * = 52.01                  r1 min = 1.27                  r2 = 2.54</p> <p><b>Hülsenhals</b></p> <p>H1 * = 8.74                  H2 <sup>1)</sup> = 8.74</p> <p><b>Geschoss</b></p> <p>G1 <sup>1)</sup> = 7.85                  G2 =                  F =                  L3+G <sup>1)</sup> = 58.56</p> <p><b>Drücke (Energien)</b></p> <p><b>Mech. elektr. Wandler</b></p> <p>Pmax = 4400 bar                  PK = 5060 bar                  PE = 5500 bar                  M = 25.00                  EE = 5250 Joule</p> <p><b>Verschiedene Daten</b></p> <p>Fe <sup>1)3)</sup> = 0.10                  delta L = 0.10</p>	<p><b>Längen</b></p> <p>L1 = 42.13                  L2 = 45.63                  L3 <sup>1)</sup> = 53.59</p> <p><b>Stoßboden</b></p> <p>R =                  R1 = 14.19                  R2 =                  R3 =                  r =</p> <p><b>Pulverkammer</b></p> <p>E = 3.35                  P1 <sup>1)</sup> = 14.15                  P2 * = 13.70</p> <p><b>Schulterkonus</b></p> <p>alpha <sup>1)</sup>* = 70°                  S * = 51.91                  r1 max = 1.27                  r2 = 3.05</p> <p><b>Hülsenhals</b></p> <p>H1 * = 8.79                  H2 <sup>1)</sup> = 8.76</p> <p><b>Geschossübergang</b></p> <p>G1 <sup>1)</sup>* = 7.87                  G <sup>1)</sup> = 5.22                  alpha1 * = 90°                  h = 0.45                  s =                  i <sup>1)</sup>* = 1°30'                  w =</p> <p><b>Lauf</b></p> <p>F <sup>1)</sup>* = 7.62                  Z <sup>1)</sup> = 7.82</p> <p><b>Züge</b></p> <p>b = 4.49                  N = 4                  u = 254.00                  Q = 47.52 mm<sup>2</sup></p>	
Maßstab 1.03:1			
Maße in << mm >> Maße und Toleranzen für Messläufe siehe Anhang CR 1.		Bemerkungen: 1) Kontrolle aus Sicherheitsgründen 3) Verschlussabstand an Schulter * Grundmaße	

<b>C.I.P.</b>	<b>308 EH</b>		<b>TAB.</b>	<b>I</b>
	Ursprungsland: FR		<b>Datum</b>	<b>89-09-20</b>
			<b>Revision</b>	<b>02-05-15</b>
	<b>PATRONE MAXI</b>		<b>PATRONENLAGER MINI</b>	
	<p><b>Längen</b></p> <p>L1 <sup>1)</sup>* = 30.45 -0.20</p> <p>L2 <sup>1)</sup>* = 34.31 -0.20</p> <p>L3 <sup>1)</sup> = 41.00</p> <p>L4 =</p> <p>L5 =</p> <p>L6 = 57.50</p> <p><b>Hülsenboden</b></p> <p>R = 1.37</p> <p>R1 = 12.01</p> <p>R3 =</p> <p>E = 3.85</p> <p>E1 = 10.39</p> <p>e min = 1.40</p> <p>delta = 36°</p> <p>f = 0.38</p> <p>beta = 45°</p> <p><b>Pulverkammer</b></p> <p>P1 = 11.96</p> <p>P2 <sup>1)</sup>* = 11.53 -0.20</p> <p><b>Schulterkonus</b></p> <p>alpha = 40°00'07"</p> <p>S = 46.29</p> <p>r1 min = 0.76</p> <p>r2 = 3.18</p> <p><b>Hülsenhals</b></p> <p>H1 * = 8.72</p> <p>H2 <sup>1)</sup> = 8.72</p> <p><b>Geschoss</b></p> <p>G1 <sup>1)</sup> = 7.85</p> <p>G2 =</p> <p>F =</p> <p>L3+G <sup>1)</sup> = 48.04</p> <p><b>Drücke (Energien)</b></p> <p><b>Mech. elektr. Wandler</b></p> <p>Pmax = 3800 bar</p> <p>PK = 4370 bar</p> <p>PE = 4750 bar</p> <p>M = 25.00</p> <p>EE = 3920 Joule</p> <p><b>Verschiedene Daten</b></p> <p>Fe <sup>1)</sup> = 0.15</p> <p>delta L = 0.10</p>		<p><b>Längen</b></p> <p>L1 * = 30.31</p> <p>L2 * = 34.11</p> <p>L3 <sup>1)</sup> = 41.26</p> <p><b>Stoßboden</b></p> <p>R =</p> <p>R1 = 12.03</p> <p>R2 =</p> <p>R3 =</p> <p>r =</p> <p><b>Pulverkammer</b></p> <p>E = 3.85</p> <p>P1 <sup>1)</sup> = 11.99</p> <p>P2 * = 11.56</p> <p><b>Schulterkonus</b></p> <p>alpha <sup>1)</sup> = 40°03'03"</p> <p>S = 46.17</p> <p>r1 max = 0.76</p> <p>r2 = 3.76</p> <p><b>Hülsenhals</b></p> <p>H1 * = 8.79</p> <p>H2 <sup>1)</sup> = 8.74</p> <p><b>Geschossübergang</b></p> <p>G1 <sup>1)</sup>* = 7.87</p> <p>G <sup>1)</sup>* = 7.04</p> <p>alpha1 = 71°52'48"</p> <p>h = 0.60</p> <p>s * = 2.89</p> <p>i <sup>1)</sup> = 1°43'31"</p> <p>w =</p> <p><b>Lauf</b></p> <p>F <sup>1)</sup>* = 7.62</p> <p>Z <sup>1)</sup> = 7.82</p> <p><b>Züge</b></p> <p>b = 4.47</p> <p>N = 4</p> <p>u = 305.00</p> <p>Q = 47.51 mm<sup>2</sup></p>	
	<b>PATRONE MAXI</b>		<b>PATRONENLAGER MINI</b>	
	<p><b>Längen</b></p> <p>L1 <sup>1)</sup>* = 30.45 -0.20</p> <p>L2 <sup>1)</sup>* = 34.31 -0.20</p> <p>L3 <sup>1)</sup> = 41.00</p> <p>L4 =</p> <p>L5 =</p> <p>L6 = 57.50</p> <p><b>Hülsenboden</b></p> <p>R = 1.37</p> <p>R1 = 12.01</p> <p>R3 =</p> <p>E = 3.85</p> <p>E1 = 10.39</p> <p>e min = 1.40</p> <p>delta = 36°</p> <p>f = 0.38</p> <p>beta = 45°</p> <p><b>Pulverkammer</b></p> <p>P1 = 11.96</p> <p>P2 <sup>1)</sup>* = 11.53 -0.20</p> <p><b>Schulterkonus</b></p> <p>alpha = 40°00'07"</p> <p>S = 46.29</p> <p>r1 min = 0.76</p> <p>r2 = 3.18</p> <p><b>Hülsenhals</b></p> <p>H1 * = 8.72</p> <p>H2 <sup>1)</sup> = 8.72</p> <p><b>Geschoss</b></p> <p>G1 <sup>1)</sup> = 7.85</p> <p>G2 =</p> <p>F =</p> <p>L3+G <sup>1)</sup> = 48.04</p> <p><b>Drücke (Energien)</b></p> <p><b>Mech. elektr. Wandler</b></p> <p>Pmax = 3800 bar</p> <p>PK = 4370 bar</p> <p>PE = 4750 bar</p> <p>M = 25.00</p> <p>EE = 3920 Joule</p> <p><b>Verschiedene Daten</b></p> <p>Fe <sup>1)</sup> = 0.15</p> <p>delta L = 0.10</p>		<p><b>Längen</b></p> <p>L1 * = 30.31</p> <p>L2 * = 34.11</p> <p>L3 <sup>1)</sup> = 41.26</p> <p><b>Stoßboden</b></p> <p>R =</p> <p>R1 = 12.03</p> <p>R2 =</p> <p>R3 =</p> <p>r =</p> <p><b>Pulverkammer</b></p> <p>E = 3.85</p> <p>P1 <sup>1)</sup> = 11.99</p> <p>P2 * = 11.56</p> <p><b>Schulterkonus</b></p> <p>alpha <sup>1)</sup> = 40°03'03"</p> <p>S = 46.17</p> <p>r1 max = 0.76</p> <p>r2 = 3.76</p> <p><b>Hülsenhals</b></p> <p>H1 * = 8.79</p> <p>H2 <sup>1)</sup> = 8.74</p> <p><b>Geschossübergang</b></p> <p>G1 <sup>1)</sup>* = 7.87</p> <p>G <sup>1)</sup>* = 7.04</p> <p>alpha1 = 71°52'48"</p> <p>h = 0.60</p> <p>s * = 2.89</p> <p>i <sup>1)</sup> = 1°43'31"</p> <p>w =</p> <p><b>Lauf</b></p> <p>F <sup>1)</sup>* = 7.62</p> <p>Z <sup>1)</sup> = 7.82</p> <p><b>Züge</b></p> <p>b = 4.47</p> <p>N = 4</p> <p>u = 305.00</p> <p>Q = 47.51 mm<sup>2</sup></p>	
Maßstab 1:1				
<p>Maße in &lt;&lt; mm &gt;&gt;</p> <p>Maße und Toleranzen für Messläufe siehe Anhang CR 1.</p>		<p>Bemerkungen: 1) Kontrolle aus Sicherheitsgründen * Grundmaße</p>		

<b>C.I.P.</b>	<b>308 Match</b> Ursprungsland: IT	<b>TAB. I</b>
		<b>Datum 14-05-20</b>
		<b>Revision</b>

Alternative Namen: 308 GAC

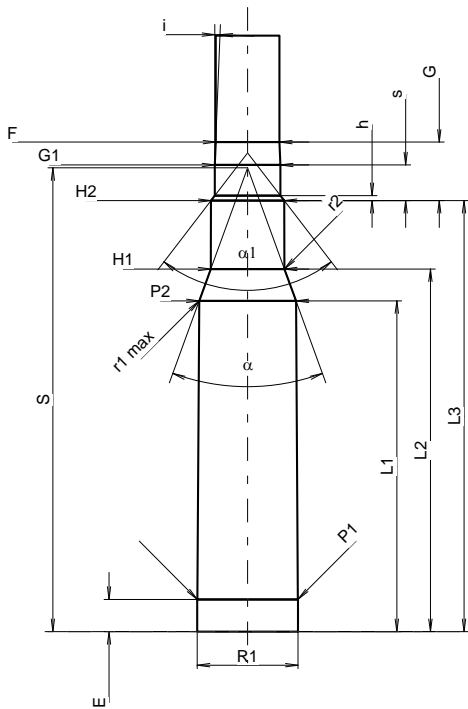
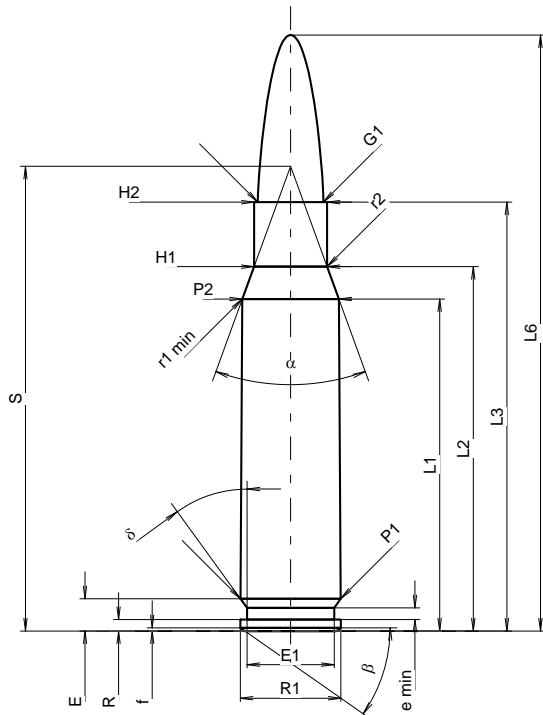

Maßstab 1.11:1

Maße in << mm >>  
Maße und Toleranzen für Messläufe  
siehe Anhang CR 1.

PATRONE MAXI			
<b>Längen</b>			
L1 <sup>1)</sup>	=	39.62	-0.20
L2 <sup>1)</sup>	=	43.48	-0.20
L3 <sup>1)</sup>	=	51.18	
L4	=		
L5	=		
L6	=	71.12	
<b>Hülsenboden</b>			
R	=	1.37	
R1	=	12.01	
R3	=		
E	=	3.85	
E1	=	10.39	
e min	=	1.40	
delta	=	36°	
f	=	0.38	
beta	=	35°	
<b>Pulverkammer</b>			
P1	=	11.96	
P2 <sup>1)</sup> *	=	11.53	-0.20
<b>Schulterkonus</b>			
alpha <sup>*</sup>	=	40°	
S <sup>*</sup>	=	55.46	
r1 min	=	0.76	
r2	=	3.18	
<b>Hülsenhals</b>			
H1 <sup>*</sup>	=	8.72	
H2 <sup>1)</sup>	=	8.72	
<b>Geschoss</b>			
G1 <sup>1)</sup>	=	7.84	
G2	=		
F	=		
L3+G <sup>1)</sup>	=	58.16	
<b>Drücke (Energien)</b>			
<b>Mech. elektr. Wandler</b>			
Pmax	=	4150 bar	
PK	=	4773 bar	
PE	=	5188 bar	
M	=	25.00	
EE	=	3600 Joule	
<b>Verschiedene Daten</b>			
Fe <sup>1)3)</sup>	=	0.10	
delta L	=	0.10	

PATRONENLAGER MINI			
<b>Längen</b>			
L1	=	39.48	
L2	=	43.28	
L3 <sup>1)</sup>	=	51.44	
<b>Stoßboden</b>			
R	=		
R1	=	12.03	
R2	=		
R3	=		
r	=		
<b>Pulverkammer</b>			
E	=	3.85	
P1 <sup>1)</sup>	=	11.99	
P2 <sup>*</sup>	=	11.56	
<b>Schulterkonus</b>			
alpha <sup>1)</sup> *	=	40°	
S <sup>*</sup>	=	55.35	
r1 max	=	0.76	
r2	=	3.68	
<b>Hülsenhals</b>			
H1 <sup>*</sup>	=	8.79	
H2 <sup>1)</sup>	=	8.74	
<b>Geschossübergang</b>			
G1 <sup>1)</sup> *	=	7.84	
G <sup>1)</sup>	=	6.98	
alpha1	=	75°	
h	=	0.59	
s <sup>*</sup>	=	4.26	
i <sup>1)</sup> *	=	2°18'57"	
w	=		
<b>Lauf</b>			
F <sup>1)</sup> *	=	7.62	
Z <sup>1)</sup>	=	7.82	
<b>Züge</b>			
b	=	4.47	
N	=	4	
u	=	305.00	
Q	=	47.51	mm <sup>2</sup>

Bemerkungen: 1) Kontrolle aus Sicherheitsgründen  
3) Verschlussabstand an Schulter  
\* Grundmaße

<b>C.I.P.</b>	<b>308 Win.</b> Ursprungsland: US	<b>TAB.</b>	<b>I</b>
		<b>Datum</b>	<b>84-06-14</b>
		<b>Revision</b>	<b>08-09-23</b>

Alternative Namen: 308 Winchester, 7,62 x 51

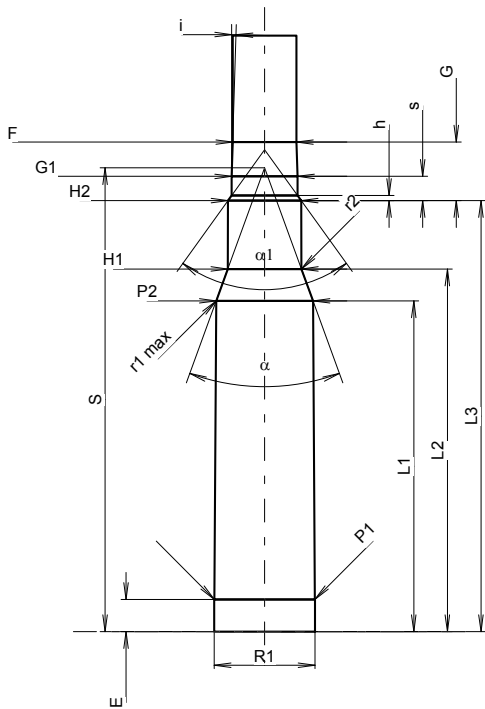
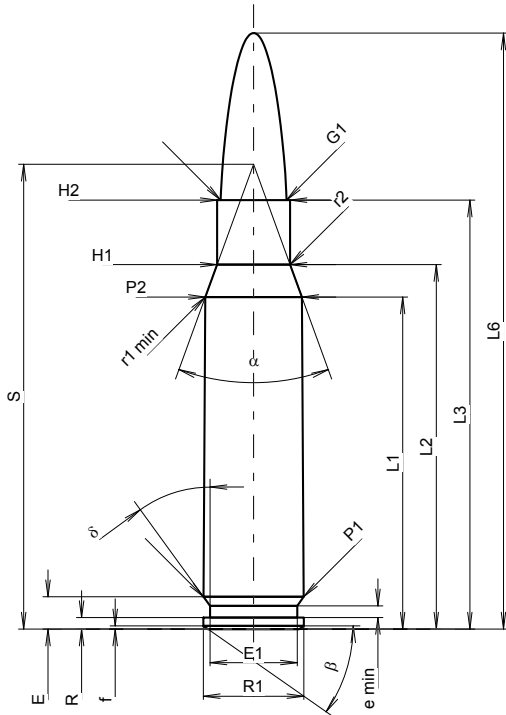

Maßstab 1.11:1

Maße in << mm >>  
Maße und Toleranzen für Messläufe  
siehe Anhang CR 1.

PATRONE MAXI			
<b>Längen</b>			
L1 <sup>1)</sup>	=	39.62	-0.20
L2 <sup>1)</sup>	=	43.48	-0.20
L3 <sup>1)</sup>	=	51.18	
L4	=		
L5	=		
L6	=	71.12	
<b>Hülsenboden</b>			
R	=	1.37	
R1	=	12.01	
R3	=		
E	=	3.85	
E1	=	10.39	
e min	=	1.40	
δ	=	36°	
f	=	0.38	
β	=	35°	
<b>Pulverkammer</b>			
P1	=	11.96	
P2 <sup>1)</sup> *	=	11.53	-0.20
<b>Schulterkonus</b>			
α <sup>*</sup>	=	40°	
S <sup>*</sup>	=	55.46	
r1 min	=	0.76	
r2	=	3.18	
<b>Hülsen Hals</b>			
H1 <sup>*</sup>	=	8.72	
H2 <sup>1)</sup>	=	8.72	
<b>Geschoss</b>			
G1 <sup>1)</sup>	=	7.85	
G2	=		
F	=		
L3+G <sup>1)</sup>	=	58.16	
<b>Drücke (Energien)</b>			
<b>Mech. elektr. Wandler</b>			
Pmax	=	4150 bar	
PK	=	4773 bar	
PE	=	5190 bar	
M	=	25.00	
EE	=	3920 Joule	
<b>Verschiedene Daten</b>			
Fe <sup>1)3)</sup>	=	0.10	
delta L	=	0.10	

PATRONENLAGER MINI			
<b>Längen</b>			
L1	=	39.48	
L2	=	43.28	
L3 <sup>1)</sup>	=	51.44	
<b>Stoßboden</b>			
R	=		
R1	=	12.03	
R2	=		
R3	=		
r	=		
<b>Pulverkammer</b>			
E	=	3.85	
P1 <sup>1)</sup>	=	11.99	
P2 <sup>*</sup>	=	11.56	
<b>Schulterkonus</b>			
α <sup>1)</sup> *	=	40°	
S <sup>*</sup>	=	55.36	
r1 max	=	0.76	
r2	=	3.68	
<b>Hülsen Hals</b>			
H1 <sup>*</sup>	=	8.79	
H2 <sup>1)</sup>	=	8.74	
<b>Geschossübergang</b>			
G1 <sup>1)</sup> *	=	7.87	
G <sup>1)</sup>	=	6.98	
α1 <sup>*</sup>	=	71°25'59"	
h	=	0.60	
s	=	2.89	
i <sup>1)</sup> *	=	1°45'	
w	=		
<b>Lauf</b>			
F <sup>1)</sup> *	=	7.62	
Z <sup>1)</sup>	=	7.82	
<b>Züge</b>			
b	=	4.47	
N	=	4	
u	=	305.00	
Q	=	47.51	mm <sup>2</sup>

Bemerkungen: 1) Kontrolle aus Sicherheitsgründen  
3) Verschlussabstand an Schulter  
\* Grundmaße

<b>C.I.P.</b>	<b>318 Riml. N.E.</b>	<b>TAB.</b>	<b>I</b>
		<b>Datum</b>	<b>84-06-14</b>
		<b>Revision</b>	<b>10-05-26</b>

Ursprungsland: GB

Alternative Namen: 318 Westley Richards

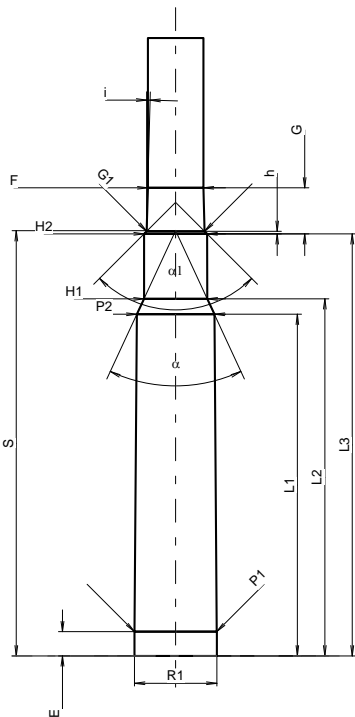
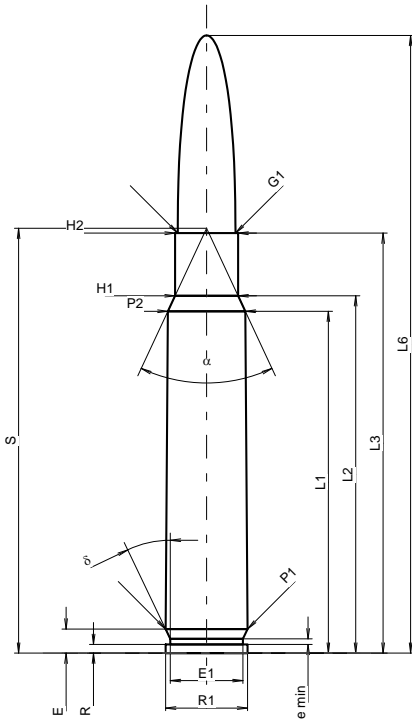

Maßstab 1:1.1

Maße in << mm >>  
Maße und Toleranzen für Messläufe  
siehe Anhang CR 1.

**PATRONE MAXI**

<b>Längen</b>			
L1 <sup>1)</sup> *	=	49.63	-0.20
L2 <sup>1)</sup> *	=	51.87	-0.20
L3 <sup>1)</sup>	=	60.96	
L4	=		
L5	=		
L6	=	89.66	

<b>Hülsenboden</b>			
R	=	1.27	
R1	=	11.89	
R3	=		
E	=	3.51	
E1	=	10.52	
e min	=	0.81	
delta	=	25°36'	
f	=		
beta	=		

<b>Pulverkammer</b>			
P1	=	11.89	
P2 <sup>1)</sup> *	=	11.23	-0.20

<b>Schulterkonus</b>			
alpha	=	50°01'10"	
S	=	61.67	
r1 min	=		
r2	=		

<b>Hülsenhals</b>			
H1 *	=	9.14	
H2 <sup>1)</sup>	=	9.12	

<b>Geschoss</b>			
G1 <sup>1)</sup>	=	8.38	
G2	=		
F	=		
L3+G <sup>1)</sup>	=	67.63	

<b>Drücke (Energien)</b>			
<b>Mech. elektr. Wandler</b>			
Pmax	=	3300 bar	
PK	=	3795 bar	
PE	=	4125 bar	
M	=	25.00	
EE	=	4550 Joule	

<b>Verschiedene Daten</b>			
Fe <sup>1)3)</sup>	=	0.15	
delta L	=		

**PATRONENLAGER MINI**

<b>Längen</b>			
L1 *	=	49.58	
L2 *	=	51.82	
L3 <sup>1)</sup>	=	61.26	

<b>Stoßboden</b>			
R	=	1.27	
R1	=	11.94	
R2	=		
R3	=		
r	=		

<b>Pulverkammer</b>			
E	=	3.51	
P1 <sup>1)</sup>	=	11.91	
P2 *	=	11.25	

<b>Schulterkonus</b>			
alpha <sup>1)</sup>	=	49°48'34"	
S	=	61.70	
r1 max	=		
r2	=		

<b>Hülsenhals</b>			
H1 *	=	9.17	
H2 <sup>1)</sup>	=	9.14	

<b>Geschossübergang</b>			
G1 <sup>1)</sup> *	=	8.40	
G <sup>1)</sup> *	=	6.67	
alpha1	=	90°	
h *	=	0.37	
s	=		
i <sup>1)</sup>	=	1°30'01"	
w	=		

<b>Lauf</b>			
F <sup>1)</sup> *	=	8.07	
Z <sup>1)</sup>	=	8.38	

<b>Züge</b>			
b	=		
N	=		
u	=	305.00	
Q	=	51.15	mm <sup>2</sup>

Bemerkungen: 1) Kontrolle aus Sicherheitsgründen  
3) Verschlussabstand an Schulter  
\* Grundmaße

<b>C.I.P.</b>	<b>32 Rem.</b>		<b>TAB.</b>	<b>I</b>
	Ursprungsland: US		<b>Datum</b>	<b>84-06-14</b>
			<b>Revision</b>	<b>02-05-15</b>
	<b>PATRONE MAXI</b>		<b>PATRONENLAGER MINI</b>	
	<p><b>Längen</b></p> <p>L1<sup>1)</sup> = 38.05 -0.20                  L2<sup>1)</sup> = 39.67 -0.20                  L3<sup>1)</sup> = 52.07                  L4 =                  L5 =                  L6 = 64.14</p> <p><b>Hülsenboden</b></p> <p>R = 1.24                  R1 = 10.72                  R3 =                  E = 3.19                  E1 = 9.09                  e min = 0.84                  delta = 36°                  beta = 35°</p> <p><b>Pulverkammer</b></p> <p>P1 = 10.71                  P2<sup>1)*</sup> = 10.19 -0.20</p> <p><b>Schulterkonus</b></p> <p>alpha* = 46°                  S* = 50.05                  r1 min = 0.64                  r2 = 2.54</p> <p><b>Hülsenhals</b></p> <p>H1* = 8.81                  H2<sup>1)</sup> = 8.73</p> <p><b>Geschoss</b></p> <p>G1<sup>1)</sup> = 8.15                  G2 =                  F =                  L3+G<sup>1)</sup> = 55.33</p> <p><b>Drücke (Energien)</b></p> <p><b>Mech. elektr. Wandler</b></p> <p>Pmax = 2950 bar                  PK = 3393 bar                  PE = 3690 bar                  M = 25.00                  EE = 2435 Joule</p> <p><b>Verschiedene Daten</b></p> <p>Fe<sup>1)</sup> = 0.15                  delta L =</p>		<p><b>Längen</b></p> <p>L1 = 38.01                  L2 = 39.66                  L3<sup>1)</sup> = 52.20</p> <p><b>Stoßboden</b></p> <p>R =                  R1 = 10.80                  R2 =                  R3 =                  r =</p> <p><b>Pulverkammer</b></p> <p>E = 3.19                  P1<sup>1)</sup> = 10.75                  P2* = 10.22</p> <p><b>Schulterkonus</b></p> <p>alpha<sup>1)*</sup> = 46°                  S* = 50.05                  r1 max = 0.64                  r2 = 2.54</p> <p><b>Hülsenhals</b></p> <p>H1* = 8.82                  H2<sup>1)</sup> = 8.74</p> <p><b>Geschossübergang</b></p> <p>G1<sup>1)*</sup> = 8.13                  G<sup>1)</sup> = 3.26                  alpha1* = 60°                  h = 0.53                  s =                  i<sup>1)*</sup> = 2°12'23"                  w =</p> <p><b>Lauf</b></p> <p>F<sup>1)*</sup> = 7.92                  Z<sup>1)</sup> = 8.10</p> <p><b>Züge</b></p> <p>b = 2.79                  N = 7                  u = 356.00                  Q = 51.10 mm<sup>2</sup></p>	
Maßstab 1:1				
Maße in << mm >> Maße und Toleranzen für Messläufe siehe Anhang CR 1.	Bemerkungen: 1) Kontrolle aus Sicherheitsgründen * Grundmaße			



<b>C.I.P.</b>	<b>325 WSM</b>		<b>TAB.</b>	<b>I</b>
	Ursprungsland: US		Datum	07-05-14
			Revision	
	<b>PATRONE MAXI</b>		<b>PATRONENLAGER MINI</b>	
	<p><b>Längen</b></p> <p>L1 <sup>1)</sup> = 42.25 -0.20                  L2 <sup>1)</sup> = 45.52 -0.20                  L3 <sup>1)</sup> = 53.34                  L4 =                  L5 =                  L6 = 72.64</p> <p><b>Hülsenboden</b></p> <p>R = 1.37                  R1 = 13.59                  R3 =                  E = 3.35                  E1 = 12.19                  e min = 1.02                  delta = 45°                  f = 0.36                  beta = 55°</p> <p><b>Pulverkammer</b></p> <p>P1 = 14.12                  P2 <sup>1)</sup>* = 13.67 -0.20</p> <p><b>Schulterkonus</b></p> <p>alpha * = 70°                  S * = 52.01                  r1 min = 1.27                  r2 = 2.54</p> <p><b>Hülsenhals</b></p> <p>H1 * = 9.09                  H2 <sup>1)</sup> = 9.09</p> <p><b>Geschoss</b></p> <p>G1 <sup>1)</sup> = 8.22                  G2 =                  F =                  L3+G <sup>1)</sup> = 63.58</p> <p><b>Drücke (Energien)</b></p> <p><b>Mech. elektr. Wandler</b></p> <p>Pmax = 4350 bar                  PK = 5000 bar                  PE = 5430 bar                  M = 25.00                  EE = 5100 Joule</p> <p><b>Verschiedene Daten</b></p> <p>Fe <sup>1)3)</sup> = 0.10                  delta L = 0.11</p>		<p><b>Längen</b></p> <p>L1 = 42.12                  L2 = 45.38                  L3 <sup>1)</sup> = 53.59</p> <p><b>Stoßboden</b></p> <p>R =                  R1 = 14.19                  R2 =                  R3 =                  r =</p> <p><b>Pulverkammer</b></p> <p>E = 3.35                  P1 <sup>1)</sup> = 14.15                  P2 * = 13.70</p> <p><b>Schulterkonus</b></p> <p>alpha <sup>1)</sup>* = 70°                  S * = 51.91                  r1 max = 1.27                  r2 = 3.05</p> <p><b>Hülsenhals</b></p> <p>H1 * = 9.14                  H2 <sup>1)</sup> = 9.12</p> <p><b>Geschossübergang</b></p> <p>G1 <sup>1)</sup>* = 8.26                  G <sup>1)</sup> = 10.24                  alpha1 * = 90°                  h = 0.43                  s = 5.28                  i <sup>1)</sup>* = 1°30'                  w =</p> <p><b>Lauf</b></p> <p>F <sup>1)</sup>* = 8.00                  Z <sup>1)</sup> = 8.20</p> <p><b>Züge</b></p> <p>b = 4.47                  N = 4                  u = 254.00                  Q = 52.16 mm<sup>2</sup></p>	
Maßstab 1:1				
Maße in << mm >> Maße und Toleranzen für Messläufe siehe Anhang CR 1.		Bemerkungen: 1) Kontrolle aus Sicherheitsgründen 3) Verschlussabstand an Schulter * Grundmaße		

<b>C.I.P.</b>	<b>333 Riml. N.E.</b>		<b>TAB.</b>	<b>I</b>
	Ursprungsland: GB		Datum	84-06-14
			Revision	02-05-15
	<b>PATRONE MAXI</b>		<b>PATRONENLAGER MINI</b>	
	<p><b>Längen</b></p> <p>L1 <sup>1)</sup>* = 44.45 -0.20                  L2 <sup>1)</sup>* = 49.20 -0.20                  L3 <sup>1)</sup> = 62.86                  L4 =                  L5 =                  L6 = 88.90</p> <p><b>Hülsenboden</b></p> <p>R = 1.27                  R1 = 13.79                  R3 =                  E = 3.30                  E1 = 12.37                  e min = 1.02                  delta = 36°02'39"                  f =                  beta =</p> <p><b>Pulverkammer</b></p> <p>P1 = 13.84                  P2 <sup>1)</sup>* = 12.70 -0.20</p> <p><b>Schulterkonus</b></p> <p>alpha = 39°42'16"                  S = 62.04                  r1 min =                  r2 =</p> <p><b>Hülsenhals</b></p> <p>H1* = 9.27                  H2 <sup>1)</sup> = 9.22</p> <p><b>Geschoss</b></p> <p>G1 <sup>1)</sup> = 8.46                  G2 =                  F =                  L3+G <sup>1)</sup> = 68.97</p> <p><b>Drücke (Energien)</b></p> <p><b>Mech. elektr. Wandler</b></p> <p>Pmax = 3300 bar                  PK = 3795 bar                  PE = 4125 bar                  M = 25.00                  EE = 4320 Joule</p> <p><b>Verschiedene Daten</b></p> <p>Fe <sup>1)</sup> = 0.15                  delta L =</p>		<p><b>Längen</b></p> <p>L1* = 44.40                  L2* = 49.15                  L3 <sup>1)</sup> = 63.17</p> <p><b>Stoßboden</b></p> <p>R = 1.27                  R1 = 13.84                  R2 =                  R3 =                  r =</p> <p><b>Pulverkammer</b></p> <p>E = 3.30                  P1 <sup>1)</sup> = 13.87                  P2* = 12.73</p> <p><b>Schulterkonus</b></p> <p>alpha <sup>1)</sup> = 39°42'16"                  S = 62.03                  r1 max =                  r2 =</p> <p><b>Hülsenhals</b></p> <p>H1* = 9.30                  H2 <sup>1)</sup> = 9.25</p> <p><b>Geschossübergang</b></p> <p>G1 <sup>1)</sup>* = 8.50                  G <sup>1)</sup>* = 6.11                  alpha1 = 90°                  h* = 0.38                  s =                  i <sup>1)</sup> = 1°29'58"                  w =</p> <p><b>Lauf</b></p> <p>F <sup>1)</sup>* = 8.20                  Z <sup>1)</sup> = 8.46</p> <p><b>Züge</b></p> <p>b =                  N =                  u =                  Q = 52.81 mm<sup>2</sup></p>	
Maßstab 1:1  Maße in << mm >> Maße und Toleranzen für Messläufe siehe Anhang CR 1.		Bemerkungen: 1) Kontrolle aus Sicherheitsgründen * Grundmaße		



<b>C.I.P.</b>	<b>338 Federal</b>		<b>TAB.</b>	<b>I</b>
	Ursprungsland: US		Datum	07-05-14
			Revision	11-05-25
	<b>PATRONE MAXI</b>		<b>PATRONENLAGER MINI</b>	
	<p><b>Längen</b></p> <p>L1 <sup>1)</sup> = 39.62 -0.20</p> <p>L2 <sup>1)</sup> = 42.55 -0.20</p> <p>L3 <sup>1)</sup> = 51.18</p> <p>L4 =</p> <p>L5 =</p> <p>L6 = 71.63</p> <p><b>Hülsenboden</b></p> <p>R = 1.37</p> <p>R1 = 12.01</p> <p>R3 =</p> <p>E = 3.85</p> <p>E1 = 10.39</p> <p>e min = 1.40</p> <p>delta = 36°</p> <p>f = 0.38</p> <p>beta = 55°</p> <p><b>Pulverkammer</b></p> <p>P1 = 11.96</p> <p>P2 <sup>1)</sup>* = 11.53 -0.20</p> <p><b>Schulterkonus</b></p> <p>alpha * = 40°</p> <p>S * = 55.46</p> <p>r1 min = 0.76</p> <p>r2 = 3.18</p> <p><b>Hülsenhals</b></p> <p>H1 * = 9.40</p> <p>H2 <sup>1)</sup> = 9.40</p> <p><b>Geschoss</b></p> <p>G1 <sup>1)</sup> = 8.61</p> <p>G2 =</p> <p>F =</p> <p>L3+G <sup>1)</sup> = 56.95</p> <p><b>Drücke (Energien)</b></p> <p><b>Mech. elektr. Wandler</b></p> <p>Pmax = 4150 bar</p> <p>PK = 4773 bar</p> <p>PE = 5188 bar</p> <p>M = 25.00</p> <p>EE = 4150 Joule</p> <p><b>Verschiedene Daten</b></p> <p>Fe <sup>1)3)</sup> = 0.10</p> <p>delta L = 0.10</p>		<p><b>Längen</b></p> <p>L1 = 39.48</p> <p>L2 = 42.38</p> <p>L3 <sup>1)</sup> = 51.44</p> <p><b>Stoßboden</b></p> <p>R =</p> <p>R1 = 12.03</p> <p>R2 =</p> <p>R3 =</p> <p>r =</p> <p><b>Pulverkammer</b></p> <p>E = 3.85</p> <p>P1 <sup>1)</sup> = 11.99</p> <p>P2 * = 11.56</p> <p><b>Schulterkonus</b></p> <p>alpha <sup>1)</sup>* = 40°</p> <p>S * = 55.36</p> <p>r1 max = 0.76</p> <p>r2 = 3.68</p> <p><b>Hülsenhals</b></p> <p>H1 * = 9.45</p> <p>H2 <sup>1)</sup> = 9.42</p> <p><b>Geschossübergang</b></p> <p>G1 <sup>1)</sup>* = 8.76</p> <p>G <sup>1)</sup> = 5.77</p> <p>alpha 1 = 90°</p> <p>h = 0.33</p> <p>s =</p> <p>i <sup>1)</sup>* = 2°</p> <p>w =</p> <p><b>Lauf</b></p> <p>F <sup>1)</sup>* = 8.38</p> <p>Z <sup>1)</sup> = 8.59</p> <p><b>Züge</b></p> <p>b = 2.75</p> <p>N = 6</p> <p>u = 254.00</p> <p>Q = 56.92 mm<sup>2</sup></p>	
Maßstab 1.08:1				
<p>Maße in &lt;&lt; mm &gt;&gt;</p> <p>Maße und Toleranzen für Messläufe siehe Anhang CR 1.</p>	<p>Bemerkungen: 1) Kontrolle aus Sicherheitsgründen 3) Verschlussabstand an Schulter * Grundmaße</p>			

<b>C.I.P.</b>	<b>338 Lapua Mag.</b>	<b>TAB.</b>	<b>I</b>
		<b>Datum</b>	<b>89-09-09</b>
		<b>Revision</b>	<b>16-10-18</b>

Ursprungsland: FI

Alternative Namen: 8,6 (mm) x 70

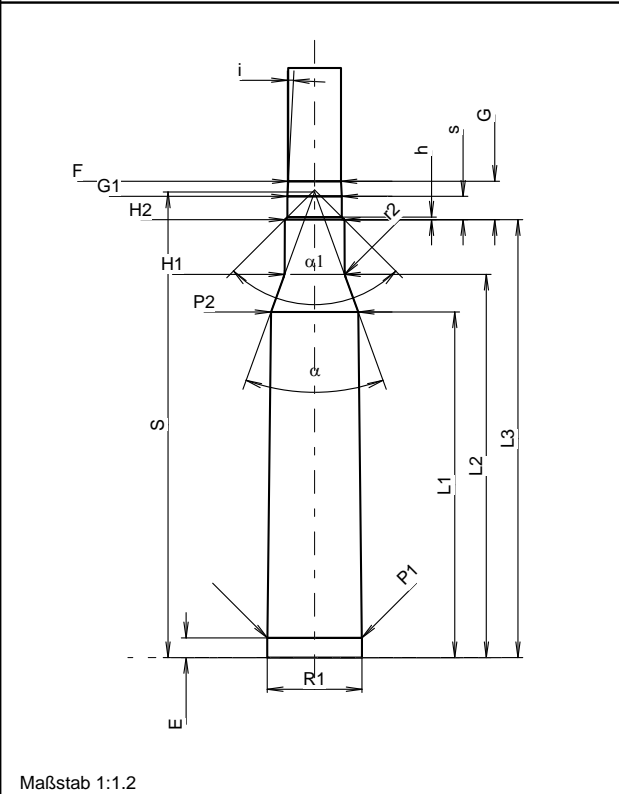
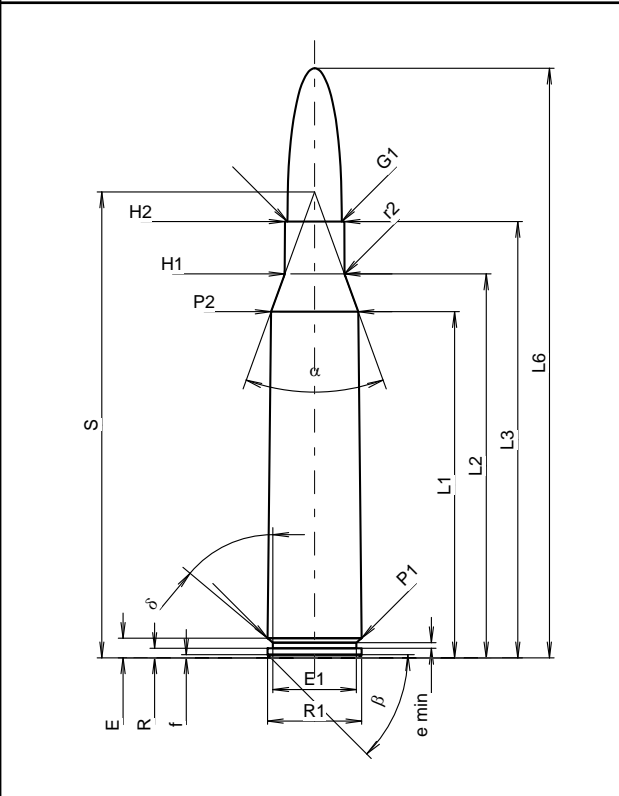

Maßstab 1:1.2

Maße in << mm >>  
Maße und Toleranzen für Messläufe  
siehe Anhang CR 1.

PATRONE MAXI		PATRONENLAGER MINI	
<b>Längen</b>			
L1 <sup>1)</sup> *	=	54.90	-0.20
L2 <sup>1)</sup> *	=	60.89	-0.20
L3 <sup>1)</sup>	=	69.20	
L4	=		
L5	=		
L6	=	93.50	
<b>Hülsenboden</b>			
R	=	1.52	
R1	=	14.93	
R3	=		
E	=	3.12	
E1	=	13.24	
e min	=	0.90	
delta	=	50°04'48"	
f	=	0.50	
beta	=	45°	
<b>Pulverkammer</b>			
P1	=	14.91	
P2 <sup>1)</sup> *	=	13.82	-0.20
<b>Schulterkonus</b>			
alpha	=	39°59'49"	
S	=	73.89	
r1 min	=		
r2	=	2.50	
<b>Hülsenhals</b>			
H1 *	=	9.46	
H2 <sup>1)</sup>	=	9.41	
<b>Geschoss</b>			
G1 <sup>1)</sup>	=	8.61	
G2	=		
F	=		
L3+G <sup>1)</sup>	=	75.28	
<b>Drücke (Energien)</b>			
<b>Mech. elektr. Wandler</b>			
Pmax	=	4200 bar	
PK	=	4830 bar	
PE	=	5250 bar	
M	=	25.00	
EE	=	6600 Joule	
<b>Verschiedene Daten</b>			
Fe <sup>1)3)</sup>	=	0.10	
delta L	=	0.05	
<b>Längen</b>			
L1 *	=	54.81	
L2 *	=	60.77	
L3 <sup>1)</sup>	=	69.45	
<b>Stoßboden</b>			
R	=		
R1	=	15.03	
R2	=		
R3	=		
r	=		
<b>Pulverkammer</b>			
E	=	3.12	
P1 <sup>1)</sup>	=	14.96	
P2 *	=	13.85	
<b>Schulterkonus</b>			
alpha <sup>1)</sup>	=	40°00'45"	
S	=	73.83	
r1 max	=		
r2	=	3.00	
<b>Hülsenhals</b>			
H1 *	=	9.51	
H2 <sup>1)</sup>	=	9.45	
<b>Geschossübergang</b>			
G1 <sup>1)</sup> *	=	8.63	
G <sup>1)</sup> *	=	6.08	
alpha1	=	90°	
h	=	0.41	
s *	=	3.70	
i <sup>1)</sup>	=	3°00'23"	
w	=		
<b>Lauf</b>			
F <sup>1)</sup> *	=	8.38	
Z <sup>1)</sup>	=	8.58	
<b>Züge</b>			
b	=	2.79	
N	=	6	
u	=	254.00	
Q	=	56.86	mm <sup>2</sup>

Bemerkungen: 1) Kontrolle aus Sicherheitsgründen  
3) Verschlussabstand an Schulter  
\* Grundmaße

<b>C.I.P.</b>	<b>338 Norma Mag.</b>	TAB.	I
		Datum	10-05-26
		Revision	
Ursprungsland: SE			
	<b>PATRONE MAXI</b>	<b>PATRONENLAGER MINI</b>	
	<p><b>Längen</b></p> <p>L1 <sup>1)</sup> = 47.78 -0.20</p> <p>L2 <sup>1)</sup> = 54.60 -0.20</p> <p>L3 <sup>1)</sup> = 63.30</p> <p>L4 =</p> <p>L5 =</p> <p>L6 = 93.50</p> <p><b>Hülsenboden</b></p> <p>R = 1.52</p> <p>R1 = 14.93</p> <p>R3 =</p> <p>E = 3.15</p> <p>E1 = 13.24</p> <p>e min = 0.95</p> <p>δ = 50°</p> <p>f = 0.50</p> <p>β = 45°</p> <p><b>Pulverkammer</b></p> <p>P1 = 14.87</p> <p>P2 <sup>1)</sup>* = 14.50 -0.20</p> <p><b>Schulterkonus</b></p> <p>α * = 41°</p> <p>S * = 67.17</p> <p>r1 min =</p> <p>r2 = 2.50</p> <p><b>Hülsenhals</b></p> <p>H1 * = 9.40</p> <p>H2 <sup>1)</sup> = 9.38</p> <p><b>Geschoss</b></p> <p>G1 <sup>1)</sup> = 8.60</p> <p>G2 =</p> <p>F =</p> <p>L3+G <sup>1)</sup> = 73.62</p> <p><b>Drücke (Energien)</b></p> <p><b>Mech. elektr. Wandler</b></p> <p>Pmax = 4400 bar</p> <p>PK = 5060 bar</p> <p>PE = 5500 bar</p> <p>M = 25.00</p> <p>EE = 6170 Joule</p> <p><b>Verschiedene Daten</b></p> <p>Fe <sup>1)3)</sup> = 0.10</p> <p>delta L =</p>	<p><b>Längen</b></p> <p>L1 = 47.59</p> <p>L2 = 54.58</p> <p>L3 <sup>1)</sup> = 63.55</p> <p><b>Stoßboden</b></p> <p>R =</p> <p>R1 = 15.03</p> <p>R2 =</p> <p>R3 =</p> <p>r =</p> <p><b>Pulverkammer</b></p> <p>E = 3.10</p> <p>P1 <sup>1)</sup> = 14.94</p> <p>P2 * = 14.66</p> <p><b>Schulterkonus</b></p> <p>α <sup>1)</sup>* = 41°</p> <p>S * = 67.19</p> <p>r1 max =</p> <p>r2 = 2.41</p> <p><b>Hülsenhals</b></p> <p>H1 * = 9.43</p> <p>H2 <sup>1)</sup> = 9.41</p> <p><b>Geschossübergang</b></p> <p>G1 <sup>1)</sup>* = 8.60</p> <p>G <sup>1)</sup> = 10.32</p> <p>α1 = 90°</p> <p>h = 0.40</p> <p>s * = 6.12</p> <p>i <sup>1)</sup>* = 1°30'</p> <p>w =</p> <p><b>Lauf</b></p> <p>F <sup>1)</sup>* = 8.38</p> <p>Z <sup>1)</sup> = 8.58</p> <p><b>Züge</b></p> <p>b = 2.79</p> <p>N = 6</p> <p>u = 235.00</p> <p>Q = 56.86 mm<sup>2</sup></p>	
<p>Maßstab 1:1.17</p> <p>Maße in &lt;&lt; mm &gt;&gt;</p> <p>Maße und Toleranzen für Messläufe siehe Anhang .</p>		<p>Bemerkungen: 1) Kontrolle aus Sicherheitsgründen 3) Verschlussabstand an Schulter * Grundmaße</p>	

<b>C.I.P.</b>	<b>338 RCM</b> Ursprungsland: US	TAB.	I
		Datum	11-05-25
		Revision	
	<b>PATRONE MAXI</b>	<b>PATRONENLAGER MINI</b>	
	<p><b>Längen</b></p> <p>L1 <sup>1)</sup> = 39.83 -0.20                  L2 <sup>1)</sup> = 43.04 -0.20                  L3 <sup>1)</sup> = 51.18                  L4 =                  L5 =                  L6 = 72.14</p> <p><b>Hülsenboden</b></p> <p>R = 1.27                  R1 = 13.51                  R3 =                  E = 3.25                  E1 = 12.07                  e min = 0.94                  delta = 35°                  f = 0.41                  beta = 45°</p> <p><b>Pulverkammer</b></p> <p>P1 = 13.53                  P2 <sup>1)</sup>* = 13.11 -0.20</p> <p><b>Schulterkonus</b></p> <p>alpha * = 60°                  S * = 51.18                  r1 min = 1.27                  r2 = 3.18</p> <p><b>Hülsenhals</b></p> <p>H1 * = 9.40                  H2 <sup>1)</sup> = 9.37</p> <p><b>Geschoss</b></p> <p>G1 <sup>1)</sup>* = 8.61                  G2 =                  F =                  L3+G <sup>1)</sup> = 59.33</p> <p><b>Drücke (Energien)</b></p> <p><b>Mech. elektr. Wandler</b></p> <p>Pmax = 4300 bar                  PK = 4945 bar                  PE = 5375 bar                  M = 25.00                  EE = 4950 Joule</p> <p><b>Verschiedene Daten</b></p> <p>Fe <sup>1)3)</sup> = 0.10                  delta L = 0.07</p>	<p><b>Längen</b></p> <p>L1 = 39.74                  L2 = 42.95                  L3 <sup>1)</sup> = 51.44</p> <p><b>Stoßboden</b></p> <p>R =                  R1 = 13.58                  R2 =                  R3 =                  r =</p> <p><b>Pulverkammer</b></p> <p>E = 3.25                  P1 <sup>1)</sup> = 13.55                  P2 * = 13.13</p> <p><b>Schulterkonus</b></p> <p>alpha <sup>1)</sup>* = 60°                  S * = 51.11                  r1 max = 0.76                  r2 = 3.18</p> <p><b>Hülsenhals</b></p> <p>H1 * = 9.42                  H2 <sup>1)</sup> = 9.40</p> <p><b>Geschossübergang</b></p> <p>G1 <sup>1)</sup>* = 8.62                  G <sup>1)</sup> = 8.15                  alpha l = 90°                  h = 0.39                  s = 3.57                  i <sup>1)</sup>* = 1°30'                  w =</p> <p><b>Lauf</b></p> <p>F <sup>1)</sup>* = 8.38                  Z <sup>1)</sup> = 8.59</p> <p><b>Züge</b></p> <p>b = 2.79                  N = 6                  u = 254.00                  Q = 56.95 mm<sup>2</sup></p>	
<p>Maßstab 1.04:1</p> <p>Maße in &lt;&lt; mm &gt;&gt; Maße und Toleranzen für Messläufe siehe Anhang CR 1.</p>	<p>Bemerkungen: 1) Kontrolle aus Sicherheitsgründen                  3) Verschlussabstand an Schulter                  * Grundmaße</p>		

C.I.P.	338 Rem. Ultra Mag.	TAB.	I
		Datum	00-10-20
		Revision	04-05-18
Ursprungsland: US			
	<p style="text-align: center;"><b>PATRONE MAXI</b></p> <p><b>Längen</b></p> <p>L1<sup>1)</sup> = 58.32 -0.20                  L2<sup>1)</sup> = 61.73 -0.20                  L3<sup>1)</sup> = 70.11                  L4 =                  L5 =                  L6 = 91.44</p> <p><b>Hülsenboden</b></p> <p>R = 1.27                  R1 = 13.57                  R3 =                  E = 3.75                  E1 = 12.06                  e min = 0.94                  delta = 32°                  f =                  beta = 35°</p> <p><b>Pulverkammer</b></p> <p>P1 = 13.98                  P2<sup>1)*</sup> = 13.37 -0.20</p> <p><b>Schulterkonus</b></p> <p>alpha* = 60°                  S* = 69.90                  r1 min = 1.52                  r2 = 3.17</p> <p><b>Hülsenhals</b></p> <p>H1* = 9.43                  H2<sup>1)</sup> = 9.43</p> <p><b>Geschoss</b></p> <p>G1<sup>1)</sup> = 8.60                  G2 =                  F =                  L3+G<sup>1)</sup> = 81.18</p> <p><b>Drücke (Energien)</b>  <b>Mech. elektr. Wandler</b></p> <p>Pmax = 4400 bar                  PK = 5060 bar                  PE = 5500 bar                  M = 25.00                  EE = 6090 Joule</p> <p><b>Verschiedene Daten</b></p> <p>Fe<sup>1)</sup> = 0.10                  delta L = 0.12</p>	<p style="text-align: center;"><b>PATRONELAGER MINI</b></p> <p><b>Längen</b></p> <p>L1 = 58.19                  L2 = 61.58                  L3<sup>1)</sup> = 70.36</p> <p><b>Stoßboden</b></p> <p>R =                  R1 = 14.05                  R2 =                  R3 =                  r =</p> <p><b>Pulverkammer</b></p> <p>E = 3.75                  P1<sup>1)</sup> = 14.02                  P2* = 13.38</p> <p><b>Schulterkonus</b></p> <p>alpha<sup>1)*</sup> = 60°                  S* = 69.78                  r1 max = 0.76                  r2 = 3.17</p> <p><b>Hülsenhals</b></p> <p>H1* = 9.47                  H2<sup>1)</sup> = 9.44</p> <p><b>Geschossübergang</b></p> <p>G1<sup>1)*</sup> = 8.61                  G<sup>1)</sup> = 11.07                  alpha1 = 89°18'50"                  h = 0.42                  s* = 4.48                  i<sup>1)*</sup> = 1°                  w =</p> <p><b>Lauf</b></p> <p>F<sup>1)*</sup> = 8.38                  Z<sup>1)</sup> = 8.59</p> <p><b>Züge</b></p> <p>b = 2.79                  N = 6                  u = 254.00                  Q = 56.95 mm<sup>2</sup></p>	
	<p>Maßstab 1:1</p> <p>Maße in &lt;&lt; mm &gt;&gt;                  Maße und Toleranzen für Messläufe                  siehe Anhang CR 1.</p>	<p>Bemerkungen: 1) Kontrolle aus Sicherheitsgründen                  * Grundmaße</p>	

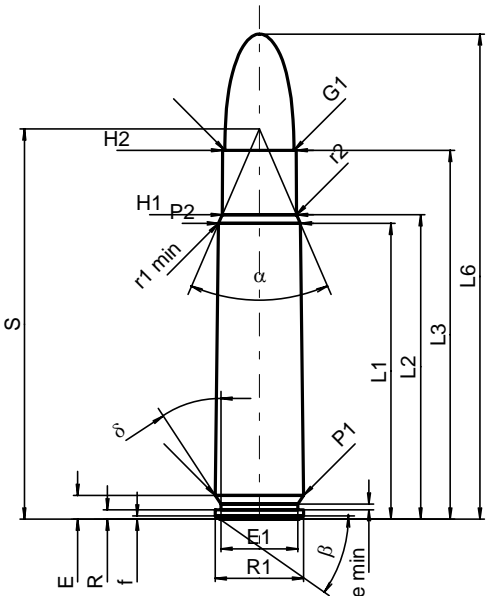
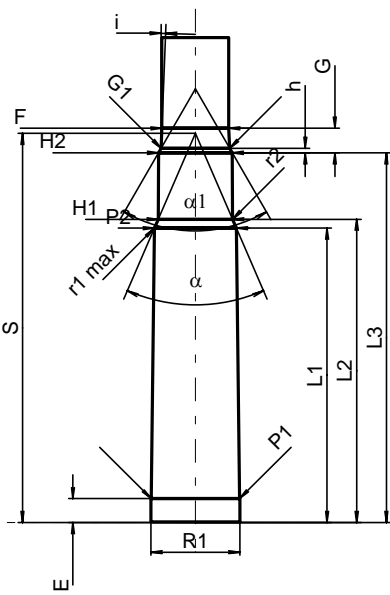

<b>C.I.P.</b>	<b>338 Win. Short Mag.</b>	TAB. <b>I</b>
		Datum <b>02-01-22</b>
		Revision <b>02-05-15</b>
Ursprungsland: US		
	<b>PATRONE MAXI</b>	<b>PATRONENLAGER MINI</b>
	<p><b>Längen</b></p> <p>L1<sup>1)</sup> = 38.64 -0.20                  L2<sup>1)</sup> = 41.74 -0.20                  L3<sup>1)</sup> = 49.78                  L4 =                  L5 =                  L6 = 69.78</p> <p><b>Hülsenboden</b></p> <p>R = 1.37                  R1 = 13.59                  R3 =                  E = 3.35                  E1 = 12.19                  e min = 1.02                  δ = 45°                  f = 0.36                  β = 35°</p> <p><b>Pulverkammer</b></p> <p>P1 = 14.12                  P2<sup>1)*</sup> = 13.71 -0.20</p> <p><b>Schulterkonus</b></p> <p>α* = 70°                  S* = 48.43                  r1 min = 1.27                  r2 = 2.54</p> <p><b>Hülsenhals</b></p> <p>H1* = 9.37                  H2<sup>1)</sup> = 9.37</p> <p><b>Geschoss</b></p> <p>G1<sup>1)</sup> = 8.69                  G2 =                  F =                  L3+G<sup>1)</sup> = 57.39</p> <p><b>Drücke (Energien)</b></p> <p><b>Mech. elektr. Wandler</b></p> <p>Pmax = 4150 bar                  PK = 4773 bar                  PE = 5188 bar                  M = 25.00                  EE = 4935 Joule</p> <p><b>Verschiedene Daten</b></p> <p>Fe<sup>1)</sup> = 0.10                  delta L = 0.10</p>	<p><b>Längen</b></p> <p>L1 = 38.51                  L2 = 41.60                  L3<sup>1)</sup> = 50.04</p> <p><b>Stoßboden</b></p> <p>R =                  R1 = 14.19                  R2 =                  R3 =                  r =</p> <p><b>Pulverkammer</b></p> <p>E = 3.35                  P1<sup>1)</sup> = 14.15                  P2* = 13.75</p> <p><b>Schulterkonus</b></p> <p>α<sup>1)*</sup> = 70°                  S* = 48.33                  r1 max = 1.27                  r2 = 3.05</p> <p><b>Hülsenhals</b></p> <p>H1* = 9.42                  H2<sup>1)</sup> = 9.40</p> <p><b>Geschossübergang</b></p> <p>G1<sup>1)*</sup> = 8.71                  G<sup>1)</sup> = 7.61                  α1* = 90°50'11"                  h = 0.34                  s = 2.89                  i<sup>1)*</sup> = 2°                  w =</p> <p><b>Lauf</b></p> <p>F<sup>1)*</sup> = 8.38                  Z<sup>1)</sup> = 8.59</p> <p><b>Züge</b></p> <p>b = 2.79                  N = 6                  u = 254.00                  Q = 56.95 mm<sup>2</sup></p>
Maßstab 1:1		
Maße in << mm >> Maße und Toleranzen für Messläufe siehe Anhang CR 1.		Bemerkungen: 1) Kontrolle aus Sicherheitsgründen * Grundmaße

<b>C.I.P.</b>	<b>35 Rem.</b>		<b>TAB.</b>	<b>I</b>
	Ursprungsland: US		<b>Datum</b>	<b>91-02-20</b>
			<b>Revision</b>	<b>02-05-15</b>
	<b>PATRONE MAXI</b>		<b>PATRONENLAGER MINI</b>	
	<p><b>Längen</b></p> <p>L1<sup>1)</sup> = 39.10 -0.20                  L2<sup>1)</sup> = 40.24 -0.20                  L3<sup>1)</sup> = 48.77                  L4 =                  L5 =                  L6 = 64.14</p> <p><b>Hülsenboden</b></p> <p>R = 1.24                  R1 = 11.68                  R3 =                  E = 3.14                  E1 = 10.16                  e min = 0.76                  delta = 34°                  f = 0.41                  beta = 35°</p> <p><b>Pulverkammer</b></p> <p>P1 = 11.66                  P2<sup>1)*</sup> = 10.82 -0.20</p> <p><b>Schulterkonus</b></p> <p>alpha* = 46°50'                  S* = 51.59                  r1 min = 0.64                  r2 = 1.27</p> <p><b>Hülsenhals</b></p> <p>H1* = 9.83                  H2<sup>1)</sup> = 9.75</p> <p><b>Geschoss</b></p> <p>G1<sup>1)</sup> = 9.12                  G2 =                  F =                  L3+G<sup>1)</sup> = 52.02</p> <p><b>Drücke (Energien)</b></p> <p><b>Mech. elektr. Wandler</b></p> <p>Pmax = 2750 bar                  PK = 3163 bar                  PE = 3575 bar                  M = 25.00                  EE = 2655 Joule</p> <p><b>Verschiedene Daten</b></p> <p>Fe<sup>1)</sup> = 0.15                  delta L = 0.13</p>		<p><b>Längen</b></p> <p>L1 = 38.91                  L2 = 40.10                  L3<sup>1)</sup> = 48.88</p> <p><b>Stoßboden</b></p> <p>R =                  R1 = 11.78                  R2 =                  R3 =                  r =</p> <p><b>Pulverkammer</b></p> <p>E = 3.14                  P1<sup>1)</sup> = 11.70                  P2* = 10.86</p> <p><b>Schulterkonus</b></p> <p>alpha<sup>1)*</sup> = 46°50'                  S* = 51.45                  r1 max = 0.64                  r2 = 1.27</p> <p><b>Hülsenhals</b></p> <p>H1* = 9.83                  H2<sup>1)</sup> = 9.75</p> <p><b>Geschossübergang</b></p> <p>G1<sup>1)*</sup> = 9.07                  G<sup>1)</sup> = 3.25                  alpha1* = 60°                  h = 0.59                  s =                  i<sup>1)*</sup> = 2°15'32"                  w =</p> <p><b>Lauf</b></p> <p>F<sup>1)*</sup> = 8.86                  Z<sup>1)</sup> = 9.07</p> <p><b>Züge</b></p> <p>b = 2.92                  N = 7                  u = 406.00                  Q = 63.84 mm<sup>2</sup></p>	
				
Maßstab 1:1				
Maße in << mm >> Maße und Toleranzen für Messläufe siehe Anhang CR 1.		Bemerkungen: 1) Kontrolle aus Sicherheitsgründen * Grundmaße		

<b>C.I.P.</b>	<b>35 Whelen</b>		<b>TAB.</b>	<b>I</b>
	Ursprungsland: US		<b>Datum</b>	<b>94-03-01</b>
			<b>Revision</b>	<b>02-05-15</b>
	<b>PATRONE MAXI</b>		<b>PATRONENLAGER MINI</b>	
	<p><b>Längen</b></p> <p>L1<sup>1)</sup> = 49.48 -0.20                  L2<sup>1)</sup> = 51.60 -0.20                  L3<sup>1)</sup> = 63.35                  L4 =                  L5 =                  L6 = 84.84</p> <p><b>Hülsenboden</b></p> <p>R = 1.24                  R1 = 12.01                  R3 =                  E = 3.16                  E1 = 10.39                  e min = 0.84                  delta = 36°                  f = 0.83                  beta = 35°</p> <p><b>Pulverkammer</b></p> <p>P1 = 11.96                  P2<sup>1)*</sup> = 11.20 -0.20</p> <p><b>Schulterkonus</b></p> <p>alpha* = 35°                  S* = 67.24                  r1 min = 1.27                  r2 = 2.54</p> <p><b>Hülsenhals</b></p> <p>H1* = 9.86                  H2<sup>1)</sup> = 9.86</p> <p><b>Geschoss</b></p> <p>G1<sup>1)</sup> = 9.12                  G2 =                  F =                  L3+G<sup>1)</sup> = 73.56</p> <p><b>Drücke (Energien)</b></p> <p><b>Mech. elektr. Wandler</b></p> <p>Pmax = 4000 bar                  PK = 4600 bar                  PE = 5000 bar                  M = 25.00                  EE = 4560 Joule</p> <p><b>Verschiedene Daten</b></p> <p>Fe<sup>1)</sup> = 0.10                  delta L = 0.15</p>		<p><b>Längen</b></p> <p>L1 = 49.27                  L2 = 51.37                  L3<sup>1)</sup> = 63.55</p> <p><b>Stoßboden</b></p> <p>R =                  R1 = 12.04                  R2 =                  R3 =                  r =</p> <p><b>Pulverkammer</b></p> <p>E = 3.16                  P1<sup>1)</sup> = 11.99                  P2* = 11.24</p> <p><b>Schulterkonus</b></p> <p>alpha<sup>1)*</sup> = 35°                  S* = 67.09                  r1 max = 1.27                  r2 = 2.54</p> <p><b>Hülsenhals</b></p> <p>H1* = 9.91                  H2<sup>1)</sup> = 9.88</p> <p><b>Geschossübergang</b></p> <p>G1<sup>1)*</sup> = 9.14                  G<sup>1)</sup> = 10.21                  alpha* = 60°                  h = 0.64                  s = 7.00                  i<sup>1)*</sup> = 2°30'                  w =</p> <p><b>Lauf</b></p> <p>F<sup>1)*</sup> = 8.86                  Z<sup>1)</sup> = 9.07</p> <p><b>Züge</b></p> <p>b = 3.30                  N = 6                  u = 406.40                  Q = 63.78 mm<sup>2</sup></p>	
	<p>Maßstab 1:1</p> <p>Maße in &lt;&lt; mm &gt;&gt;                  Maße und Toleranzen für Messläufe                  siehe Anhang CR 1.</p>			
		<p>Bemerkungen: 1) Kontrolle aus Sicherheitsgründen                  * Grundmaße</p>		

<b>C.I.P.</b>	<b>350 Mag. Rigby</b>		<b>TAB.</b>	<b>I</b>
	Ursprungsland: GB		Datum	84-06-14
			Revision	02-05-15
	<b>PATRONE MAXI</b>		<b>PATRONENLAGER MINI</b>	
	<p><b>Längen</b></p> <p>L1 <sup>1)</sup>* = 57.15 -0.20                  L2 <sup>1)</sup>* = 57.99 -0.20                  L3 <sup>1)</sup> = 69.85                  L4 =                  L5 =                  L6 = 90.80</p> <p><b>Hülsenboden</b></p> <p>R = 1.52                  R1 = 13.36                  R3 =                  E = 3.81                  E1 = 11.61                  e min = 0.76                  δ = 26°51'36"                  f =                  β =</p> <p><b>Pulverkammer</b></p> <p>P1 = 13.16                  P2 <sup>1)</sup>* = 11.43 -0.20</p> <p><b>Schulterkonus</b></p> <p>α = 90°                  S = 62.86                  r1 min =                  r2 =</p> <p><b>Hülsenhals</b></p> <p>H1* = 9.75                  H2 <sup>1)</sup> = 9.73</p> <p><b>Geschoss</b></p> <p>G1 <sup>1)</sup> = 9.07                  G2 =                  F =                  L3+G <sup>1)</sup> = 74.75</p> <p><b>Drücke (Energien)</b>  <b>Mech. elektr. Wandler</b></p> <p>Pmax = 3100 bar                  PK = 3565 bar                  PE = 3875 bar                  M = 25.00                  EE = 4810 Joule</p> <p><b>Verschiedene Daten</b></p> <p>Fe <sup>1)</sup> = 0.15                  delta L =</p>		<p><b>Längen</b></p> <p>L1* = 57.10                  L2* = 57.94                  L3 <sup>1)</sup> = 70.15</p> <p><b>Stoßboden</b></p> <p>R = 1.52                  R1 = 13.41                  R2 =                  R3 =                  r =</p> <p><b>Pulverkammer</b></p> <p>E = 3.81                  P1 <sup>1)</sup> = 13.18                  P2* = 11.46</p> <p><b>Schulterkonus</b></p> <p>α <sup>1)</sup> = 90°                  S = 62.83                  r1 max =                  r2 =</p> <p><b>Hülsenhals</b></p> <p>H1* = 9.78                  H2 <sup>1)</sup> = 9.75</p> <p><b>Geschossübergang</b></p> <p>G1 <sup>1)</sup>* = 9.13                  G <sup>1)</sup>* = 4.90                  α1 = 180°                  h =                  s =                  i <sup>1)</sup>* = 1°30'                  w =</p> <p><b>Lauf</b></p> <p>F <sup>1)</sup>* = 8.89                  Z <sup>1)</sup> = 9.06</p> <p><b>Züge</b></p> <p>b =                  N =                  u = 305.00                  Q = 62.07 mm<sup>2</sup></p>	
Maßstab 1:1				
Maße in << mm >> Maße und Toleranzen für Messläufe siehe Anhang CR 1.		Bemerkungen: 1) Kontrolle aus Sicherheitsgründen * Grundmaße		

C.I.P.	358 Win. Ursprungsland: US	TAB.	I
		Datum	84-06-14
		Revision	02-05-15
	<p><b>PATRONE MAXI</b></p> <p><b>Längen</b></p> <p>L1 <sup>1)</sup> = 39.62 -0.20                  L2 <sup>1)</sup> = 41.91 -0.20                  L3 <sup>1)</sup> = 51.18                  L4 =                  L5 =                  L6 = 70.61</p> <p><b>Hülsenboden</b></p> <p>R = 1.37                  R1 = 12.01                  R3 =                  E = 3.85                  E1 = 10.39                  e min = 1.40                  delta = 36°                  f = 0.38                  beta = 35°</p> <p><b>Pulverkammer</b></p> <p>P1 = 11.96                  P2 <sup>1)*</sup> = 11.53 -0.20</p> <p><b>Schulterkonus</b></p> <p>alpha * = 40°                  S * = 55.46                  r1 min = 0.76                  r2 = 2.54</p> <p><b>Hülsenhals</b></p> <p>H1 * = 9.86                  H2 <sup>1)</sup> = 9.86</p> <p><b>Geschoss</b></p> <p>G1 <sup>1)</sup> = 9.11                  G2 =                  F =                  L3+G <sup>1)</sup> = 57.14</p> <p><b>Drücke (Energien)</b>  <b>Mech. elektr. Wandler</b></p> <p>Pmax = 4050 bar                  PK = 4658 bar                  PE = 5060 bar                  M = 25.00                  EE = 4270 Joule</p> <p><b>Verschiedene Daten</b></p> <p>Fe <sup>1)</sup> = 0.10                  delta L = 0.10</p>	<p><b>PATRONE MINI</b></p> <p><b>Längen</b></p> <p>L1 = 39.48                  L2 = 41.72                  L3 <sup>1)</sup> = 51.44</p> <p><b>Stoßboden</b></p> <p>R =                  R1 = 12.03                  R2 =                  R3 =                  r =</p> <p><b>Pulverkammer</b></p> <p>E = 3.85                  P1 <sup>1)</sup> = 11.99                  P2 * = 11.56</p> <p><b>Schulterkonus</b></p> <p>alpha <sup>1)*</sup> = 40°                  S * = 55.36                  r1 max = 0.76                  r2 = 2.79</p> <p><b>Hülsenhals</b></p> <p>H1 * = 9.93                  H2 <sup>1)</sup> = 9.88</p> <p><b>Geschossübergang</b></p> <p>G1 <sup>1)*</sup> = 9.17                  G <sup>1)</sup> = 5.96                  alpha 1 * = 60°                  h = 0.61                  s =                  i <sup>1)*</sup> = 1°30'                  w =</p> <p><b>Lauf</b></p> <p>F <sup>1)*</sup> = 8.89                  Z <sup>1)</sup> = 9.09</p> <p><b>Züge</b></p> <p>b = 2.79                  N = 6                  u = 305.00                  Q = 63.77 mm<sup>2</sup></p>	

<b>C.I.P.</b>	<b>375 Blaser Mag.</b>	<b>TAB.</b>	<b>I</b>
		<b>Datum</b>	<b>09-05-05</b>
		<b>Revision</b>	
Ursprungsland: SE			
	<b>PATRONE MAXI</b>		
	<p><b>Längen</b></p> <p>L1 <sup>1)</sup> = 59.13 -0.20                  L2 <sup>1)</sup> = 61.37 -0.20                  L3 <sup>1)</sup> = 71.70                  L4 =                  L5 =                  L6 = 92.00</p> <p><b>Hülsenboden</b></p> <p>R = 1.37                  R1 = 13.59                  R3 =                  E = 3.61                  E1 = 12.19                  e min = 1.42                  delta = 45°                  f = 0.30                  beta = 35°</p> <p><b>Pulverkammer</b></p> <p>P1 = 13.84                  P2 <sup>1)</sup>* = 12.90 -0.20</p> <p><b>Schulterkonus</b></p> <p>alpha * = 60°                  S * = 70.30                  r1 min = 1.50                  r2 = 2.00</p> <p><b>Hülsenhals</b></p> <p>H1 * = 10.31                  H2 <sup>1)</sup> = 10.31</p> <p><b>Geschoss</b></p> <p>G1 <sup>1)</sup> = 9.53                  G2 =                  F =                  L3+G <sup>1)</sup> = 84.25</p> <p><b>Drücke (Energien)</b></p> <p><b>Mech. elektr. Wandler</b></p> <p>Pmax = 4200 bar                  PK = 4830 bar                  PE = 5250 bar                  M = 25.00                  EE = 7370 Joule</p> <p><b>Verschiedene Daten</b></p> <p>Fe <sup>1)3)</sup> = 0.10                  delta L = 0.02</p>		
	<b>PATRONENLAGER MINI</b>		
	<p><b>Längen</b></p> <p>L1 = 59.08                  L2 = 61.29                  L3 <sup>1)</sup> = 72.00</p> <p><b>Stoßboden</b></p> <p>R = 1.37                  R1 = 13.92                  R2 =                  R3 =                  r =</p> <p><b>Pulverkammer</b></p> <p>E = 3.61                  P1 <sup>1)</sup> = 13.87                  P2 * = 12.93</p> <p><b>Schulterkonus</b></p> <p>alpha <sup>1)</sup>* = 60°                  S * = 70.29                  r1 max = 1.50                  r2 = 2.00</p> <p><b>Hülsenhals</b></p> <p>H1 * = 10.38                  H2 <sup>1)</sup> = 10.33</p> <p><b>Geschossübergang</b></p> <p>G1 <sup>1)</sup>* = 9.55                  G <sup>1)</sup> = 12.55                  alpha1 = 90°                  h = 0.39                  s * = 3.00                  i <sup>1)</sup>* = 0°45'                  w =</p> <p><b>Lauf</b></p> <p>F <sup>1)</sup>* = 9.30                  Z <sup>1)</sup> = 9.55</p> <p><b>Züge</b></p> <p>b = 4.49                  N = 4                  u = 355.60                  Q = 70.27 mm<sup>2</sup></p>		
<p>Maßstab 1:1.17</p> <p>Maße in &lt;&lt; mm &gt;&gt;                  Maße und Toleranzen für Messläufe                  siehe Anhang CR 1.</p>		<p>Bemerkungen: 1) Kontrolle aus Sicherheitsgründen                  3) Verschlussabstand an Schulter                  * Grundmaße</p>	

<b>C.I.P.</b>	<b>375 Hölderlin</b>		<b>TAB.</b>	<b>I</b>
			<b>Datum</b>	<b>07-05-14</b>
	Ursprungsland: DE		<b>Revision</b>	
	<b>PATRONE MAXI</b>		<b>PATRONENLAGER MINI</b>	
	<p><b>Längen</b></p> <p>L1 <sup>1)</sup> = 53.20 -0.20                  L2 <sup>1)</sup> = 56.57 -0.20                  L3 <sup>1)</sup> = 67.50                  L4 =                  L5 =                  L6 = 87.00</p> <p><b>Hülsenboden</b></p> <p>R = 1.40                  R1 = 13.00                  R3 =                  E = 3.50                  E1 = 11.20                  e min = 1.00                  delta = 43°40'12"                  f = 0.30                  beta = 45°</p> <p><b>Pulverkammer</b></p> <p>P1 = 13.30                  P2 <sup>1)</sup>* = 12.15 -0.20</p> <p><b>Schulterkonus</b></p> <p>alpha * = 29°05'34"                  S * = 76.60                  r1 min = 0.50                  r2 = 0.50</p> <p><b>Hülsenhals</b></p> <p>H1 * = 10.40                  H2 <sup>1)</sup> = 10.39</p> <p><b>Geschoss</b></p> <p>G1 <sup>1)</sup> = 9.55                  G2 =                  F =                  L3+G <sup>1)</sup> = 74.22</p> <p><b>Drücke (Energien)</b></p> <p><b>Mech. elektr. Wandler</b></p> <p>Pmax = 3800 bar                  PK = 4370 bar                  PE = 4750 bar                  M = 25.00                  EE = 6800 Joule</p> <p><b>Verschiedene Daten</b></p> <p>Fe <sup>1)3)</sup> = 0.10                  delta L =</p>		<p><b>Längen</b></p> <p>L1 = 53.14                  L2 = 56.51                  L3 <sup>1)</sup> = 67.80</p> <p><b>Stoßboden</b></p> <p>R = 1.40                  R1 = 13.05                  R2 =                  R3 =                  r =</p> <p><b>Pulverkammer</b></p> <p>E = 3.50                  P1 <sup>1)</sup> = 13.33                  P2 * = 12.18</p> <p><b>Schulterkonus</b></p> <p>alpha <sup>1)</sup>* = 29°05'34"                  S * = 76.61                  r1 max = 0.50                  r2 = 0.50</p> <p><b>Hülsenhals</b></p> <p>H1 * = 10.43                  H2 <sup>1)</sup> = 10.42</p> <p><b>Geschossübergang</b></p> <p>G1 <sup>1)</sup>* = 9.56                  G <sup>1)</sup> = 6.72                  alpha1 * = 90°                  h = 0.43                  s * = 3.00                  i <sup>1)</sup> = 2°                  w =</p> <p><b>Lauf</b></p> <p>F <sup>1)</sup>* = 9.30                  Z <sup>1)</sup> = 9.55</p> <p><b>Züge</b></p> <p>b = 2.92                  N = 6                  u = 305.00                  Q = 70.16 mm<sup>2</sup></p>	
<p>Maßstab 1:1</p> <p>Maße in &lt;&lt; mm &gt;&gt;                  Maße und Toleranzen für Messläufe                  siehe Anhang CR 1.</p>		<p>Bemerkungen: 1) Kontrolle aus Sicherheitsgründen                  3) Verschlussabstand an Schulter                  * Grundmaße</p>		

<b>C.I.P.</b>	<b>375 Rem. Ultra Mag.</b>	TAB. <b>I</b>
		Datum <b>02-01-22</b>
		Revision <b>07-06-20</b>
Ursprungsland: US		
	<b>PATRONE MAXI</b>	<b>PATRONENLAGER MINI</b>
	<p><b>Längen</b></p> <p>L1<sup>1)</sup> = 60.64 -0.20                  L2<sup>1)</sup> = 63.28 -0.20                  L3<sup>1)</sup> = 72.39                  L4 =                  L5 =                  L6 = 91.44</p> <p><b>Hülsenboden</b></p> <p>R = 1.27                  R1 = 13.56                  R3 =                  E = 3.75                  E1 = 12.07                  e min = 0.94                  delta = 32°                  f = 0.31                  beta = 35°</p> <p><b>Pulverkammer</b></p> <p>P1 = 13.99                  P2<sup>1)*</sup> = 13.33 -0.20</p> <p><b>Schulterkonus</b></p> <p>alpha* = 60°                  S* = 72.18                  r1 min = 0.76                  r2 = 3.18</p> <p><b>Hülsenhals</b></p> <p>H1* = 10.29                  H2<sup>1)</sup> = 10.29</p> <p><b>Geschoss</b></p> <p>G1<sup>1)</sup> = 9.55                  G2 =                  F =                  L3+G<sup>1)</sup> = 84.38</p> <p><b>Drücke (Energien)</b></p> <p><b>Mech. elektr. Wandler</b></p> <p>Pmax = 4400 bar                  PK = 5060 bar                  PE = 5500 bar                  M = 25.00                  EE = 7350 Joule</p> <p><b>Verschiedene Daten</b></p> <p>Fe<sup>1)</sup> = 0.10                  delta L = 0.10</p>	<p><b>Längen</b></p> <p>L1 = 60.51                  L2 = 63.13                  L3<sup>1)</sup> = 72.64</p> <p><b>Stoßboden</b></p> <p>R =                  R1 = 14.05                  R2 =                  R3 =                  r =</p> <p><b>Pulverkammer</b></p> <p>E = 3.75                  P1<sup>1)</sup> = 14.02                  P2* = 13.36</p> <p><b>Schulterkonus</b></p> <p>alpha<sup>1)*</sup> = 60°                  S* = 72.08                  r1 max = 0.76                  r2 = 3.18</p> <p><b>Hülsenhals</b></p> <p>H1* = 10.34                  H2<sup>1)</sup> = 10.31</p> <p><b>Geschossübergang</b></p> <p>G1<sup>1)*</sup> = 9.55                  G<sup>1)</sup> = 11.99                  alpha1 = 90°                  h = 0.38                  s* = 4.83                  i<sup>1)*</sup> = 1°                  w =</p> <p><b>Lauf</b></p> <p>F<sup>1)*</sup> = 9.30                  Z<sup>1)</sup> = 9.55</p> <p><b>Züge</b></p> <p>b = 2.92                  N = 6                  u = 304.80                  Q = 70.16 mm<sup>2</sup></p>
Maßstab 1:1		
Maße in << mm >> Maße und Toleranzen für Messläufe siehe Anhang CR 1.		Bemerkungen: 1) Kontrolle aus Sicherheitsgründen * Grundmaße



<b>C.I.P.</b>	<b>375 Ruger</b>		<b>TAB.</b>	<b>I</b>
	Ursprungsland: US		<b>Datum</b>	<b>09-05-05</b>
			<b>Revision</b>	
	<b>PATRONE MAXI</b>		<b>PATRONENLAGER MINI</b>	
	<p><b>Längen</b></p> <p>L1 <sup>1)</sup> = 55.36 -0.20                      L2 <sup>1)</sup> = 57.78 -0.20                      L3 <sup>1)</sup> = 65.53                      L4 =                      L5 =                      L6 = 84.84</p> <p><b>Hülsenboden</b></p> <p>R = 1.27                      R1 = 13.51                      R3 =                      E = 3.24                      E1 = 12.07                      e min = 0.94                      delta = 35°                      f = 0.41                      beta = 35°</p> <p><b>Pulverkammer</b></p> <p>P1 = 13.52                      P2 <sup>1)</sup>* = 13.08 -0.20</p> <p><b>Schulterkonus</b></p> <p>alpha * = 60°                      S * = 66.70                      r1 min = 0.76                      r2 = 3.18</p> <p><b>Hülsenhals</b></p> <p>H1 * = 10.29                      H2 <sup>1)</sup> = 10.29</p> <p><b>Geschoss</b></p> <p>G1 <sup>1)</sup> = 9.55                      G2 =                      F =                      L3+G <sup>1)</sup> = 74.04</p> <p><b>Drücke (Energien)</b></p> <p><b>Mech. elektr. Wandler</b></p> <p>Pmax = 4275 bar                      PK = 4916 bar                      PE = 5344 bar                      M = 25.00                      EE = 6350 Joule</p> <p><b>Verschiedene Daten</b></p> <p>Fe <sup>1)3)</sup> = 0.10                      delta L = 0.10</p>		<p><b>Längen</b></p> <p>L1 = 55.24                      L2 = 57.64                      L3 <sup>1)</sup> = 65.79</p> <p><b>Stoßboden</b></p> <p>R =                      R1 = 13.58                      R2 =                      R3 =                      r =</p> <p><b>Pulverkammer</b></p> <p>E = 3.24                      P1 <sup>1)</sup> = 13.55                      P2 * = 13.11</p> <p><b>Schulterkonus</b></p> <p>alpha <sup>1)</sup>* = 60°                      S * = 66.60                      r1 max = 0.76                      r2 = 3.18</p> <p><b>Hülsenhals</b></p> <p>H1 * = 10.34                      H2 <sup>1)</sup> = 10.31</p> <p><b>Geschossübergang</b></p> <p>G1 <sup>1)</sup>* = 9.56                      G <sup>1)</sup> = 8.51                      alpha l = 90°                      h = 0.38                      s * = 3.55                      i <sup>1)</sup>* = 1°30'                      w =</p> <p><b>Lauf</b></p> <p>F <sup>1)</sup>* = 9.30                      Z <sup>1)</sup> = 9.55</p> <p><b>Züge</b></p> <p>b = 2.92                      N = 6                      u = 305.00                      Q = 70.16 mm<sup>2</sup></p>	
<p>Maßstab 1:1.06</p> <p>Maße in &lt;&lt; mm &gt;&gt;                      Maße und Toleranzen für Messläufe                      siehe Anhang CR 1.</p>		<p>Bemerkungen: 1) Kontrolle aus Sicherheitsgründen                      3) Verschlussabstand an Schulter                      * Grundmaße</p>		

<b>C.I.P.</b>	<b>376 Steyr</b>		<b>TAB.</b>	<b>I</b>
	Ursprungsland: AT		Datum	99-01-20
			Revision	02-05-15
	<b>PATRONE MAXI</b>		<b>PATRONENLAGER MINI</b>	
	<p><b>Längen</b></p> <p>L1 <sup>1)</sup>* = 48.09 -0.20                  L2 <sup>1)</sup>* = 50.97 -0.20                  L3 <sup>1)</sup> = 60.00                  L4 =                  L5 =                  L6 = 79.00</p> <p><b>Hülsenboden</b></p> <p>R = 1.30                  R1 = 12.60                  R3 =                  E = 3.20                  E1 = 11.20                  e min = 1.00                  delta = 43°                  f = 0.30                  beta = 45°</p> <p><b>Pulverkammer</b></p> <p>P1 = 12.88                  P2 <sup>1)</sup>* = 12.05 -0.20</p> <p><b>Schulterkonus</b></p> <p>alpha = 35°04'13"                  S = 67.16                  r1 min =                  r2 =</p> <p><b>Hülsenhals</b></p> <p>H1* = 10.23                  H2 <sup>1)</sup> = 10.23</p> <p><b>Geschoss</b></p> <p>G1 <sup>1)</sup> = 9.55                  G2 =                  F =                  L3+G <sup>1)</sup> = 76.28</p> <p><b>Drücke (Energien)</b></p> <p><b>Mech. elektr. Wandler</b></p> <p>Pmax = 4300 bar                  PK = 4945 bar                  PE = 5375 bar                  M = 25.00                  EE = 5200 Joule</p> <p><b>Verschiedene Daten</b></p> <p>Fe <sup>1)</sup> = 0.10                  delta L =</p>		<p><b>Längen</b></p> <p>L1* = 48.04                  L2* = 50.88                  L3 <sup>1)</sup> = 60.30</p> <p><b>Stoßboden</b></p> <p>R = 1.30                  R1 = 12.65                  R2 =                  R3 =                  r =</p> <p><b>Pulverkammer</b></p> <p>E = 3.20                  P1 <sup>1)</sup> = 12.91                  P2* = 12.08</p> <p><b>Schulterkonus</b></p> <p>alpha <sup>1)</sup> = 34°59'01"                  S = 67.21                  r1 max = 0.50                  r2 = 0.50</p> <p><b>Hülsenhals</b></p> <p>H1* = 10.29                  H2 <sup>1)</sup> = 10.26</p> <p><b>Geschossübergang</b></p> <p>G1 <sup>1)</sup>* = 9.70                  G <sup>1)</sup>* = 16.28                  alpha1 = 90°                  h* = 0.28                  s =                  i <sup>1)</sup> = 0°42'58"                  w =</p> <p><b>Lauf</b></p> <p>F <sup>1)</sup>* = 9.30                  Z <sup>1)</sup> = 9.55</p> <p><b>Züge</b></p> <p>b = 2.92                  N = 6                  u = 305.00                  Q = 70.16 mm<sup>2</sup></p>	
Maßstab 1:1				
Maße in << mm >> Maße und Toleranzen für Messläufe siehe Anhang CR 1.		Bemerkungen: 1) Kontrolle aus Sicherheitsgründen * Grundmaße		

<b>C.I.P.</b>	<b>404 Riml. N.E.</b>		<b>TAB.</b>	<b>I</b>
	Ursprungsland: GB		<b>Datum</b>	<b>84-06-14</b>
			<b>Revision</b>	<b>05-05-25</b>
	<b>PATRONE MAXI</b>		<b>PATRONENLAGER MINI</b>	
	<p><b>Längen</b></p> <p>L1 <sup>1)</sup>* = 50.82 -0.20                      L2 <sup>1)</sup>* = 57.18 -0.20                      L3 <sup>1)</sup> = 73.02                      L4 =                      L5 =                      L6 = 89.66</p> <p><b>Hülsenboden</b></p> <p>R = 1.27                      R1 = 13.79                      R3 =                      E = 3.30                      E1 = 12.37                      e min = 1.02                      delta = 36°02'39"                      f =                      beta =</p> <p><b>Pulverkammer</b></p> <p>P1 = 13.84                      P2 <sup>1)</sup>* = 13.46 -0.20</p> <p><b>Schulterkonus</b></p> <p>alpha = 16°59'27"                      S = 95.88                      r1 min =                      r2 =</p> <p><b>Hülsenhals</b></p> <p>H1* = 11.56                      H2 <sup>1)</sup> = 11.48</p> <p><b>Geschoss</b></p> <p>G1 <sup>1)</sup> = 10.72                      G2 =                      F =                      L3+G <sup>1)</sup> = 80.64</p> <p><b>Drücke (Energien)</b></p> <p><b>Mech. elektr. Wandler</b></p> <p>Pmax = 3650 bar                      PK = 4198 bar                      PE = 4560 bar                      M = 25.00                      EE = 6815 Joule</p> <p><b>Verschiedene Daten</b></p> <p>Fe <sup>1)</sup> = 0.15                      delta L =</p>		<p><b>Längen</b></p> <p>L1* = 50.77                      L2* = 57.13                      L3 <sup>1)</sup> = 73.33</p> <p><b>Stoßboden</b></p> <p>R = 1.27                      R1 = 13.84                      R2 =                      R3 =                      r =</p> <p><b>Pulverkammer</b></p> <p>E = 3.30                      P1 <sup>1)</sup> = 13.87                      P2* = 13.49</p> <p><b>Schulterkonus</b></p> <p>alpha <sup>1)</sup> = 17°04'45"                      S = 95.69                      r1 max =                      r2 =</p> <p><b>Hülsenhals</b></p> <p>H1* = 11.58                      H2 <sup>1)</sup> = 11.51</p> <p><b>Geschossübergang</b></p> <p>G1 <sup>1)</sup>* = 10.77                      G <sup>1)</sup>* = 7.62                      alpha1 = 90°                      h* = 0.37                      s =                      i <sup>1)</sup> = 1°13'29"                      w =</p> <p><b>Lauf</b></p> <p>F <sup>1)</sup>* = 10.46                      Z <sup>1)</sup> = 10.77</p> <p><b>Züge</b></p> <p>b = 3.50                      N = 6                      u = 420.00                      Q = 89.25 mm<sup>2</sup></p>	
<p>Maßstab 1:1</p> <p>Maße in &lt;&lt; mm &gt;&gt;                      Maße und Toleranzen für Messläufe                      siehe Anhang CR 1.</p>		<p>Bemerkungen: 1) Kontrolle aus Sicherheitsgründen                      * Grundmaße</p>		



<b>C.I.P.</b>	<b>416 A-TEC</b> Ursprungsland: NO	<b>TAB.</b>	<b>I</b>
		<b>Datum</b>	<b>16-05-18</b>
		<b>Revision</b>	

Alternative Namen: 416 A-SUB

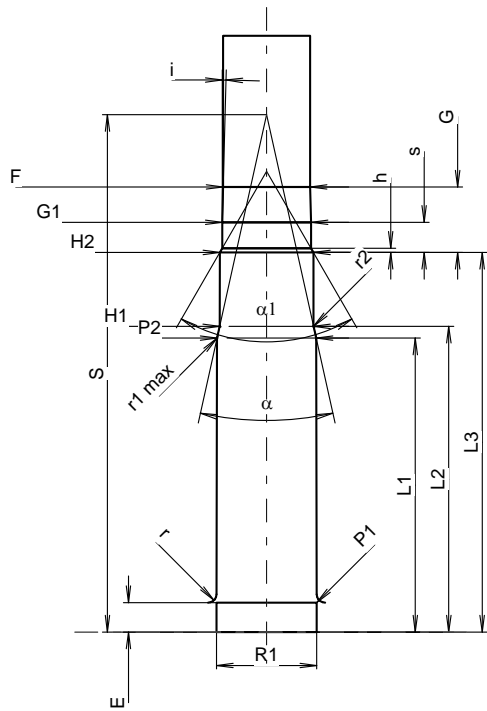
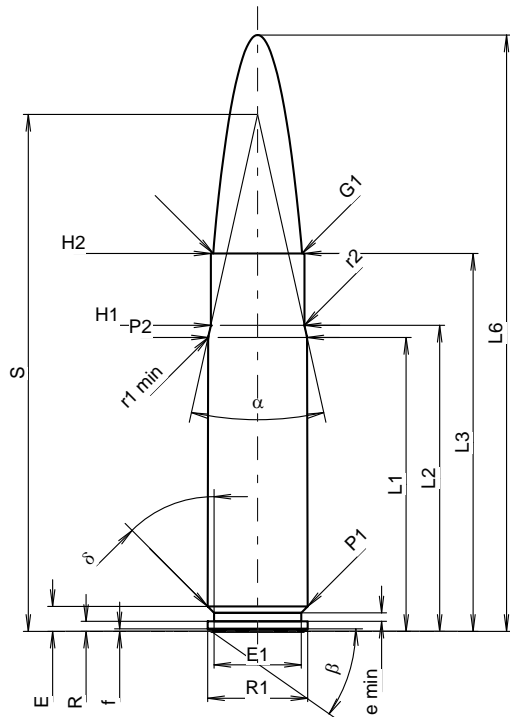

Maßstab 1.11:1

Maße in << mm >>  
Maße und Toleranzen für Messläufe  
siehe Anhang CR 1.

**PATRONE MAXI**

<b>Längen</b>			
L1 <sup>1)</sup>	=	35.00	-0.20
L2 <sup>1)</sup>	=	36.44	-0.20
L3 <sup>1)</sup>	=	45.00	
L4	=		
L5	=		
L6	=	71.00	

**Hülsenboden**

R	=	1.20	
R1	=	11.90	
R3	=		
E	=	2.97	
E1	=	10.39	
e min	=	1.00	
delta	=	45°	
f	=	0.30	
beta	=	35°	

**Pulverkammer**

P1	=	11.92	
P2 <sup>1)</sup> *	=	11.77	-0.20

**Schulterkonus**

alpha *	=	25°	
S *	=	61.54	
r1 min	=	2.00	
r2	=	0.50	

**Hülsenhals**

H1 *	=	11.13	
H2 <sup>1)</sup>	=	11.13	

**Geschoss**

G1 <sup>1)</sup>	=	10.57	
G2	=		
F	=		
L3+G <sup>1)</sup>	=	52.79	

**Drücke (Energien)**

<b>Mech. elektr. Wandler</b>		
Pmax	=	4150 bar
PK	=	4773 bar
PE	=	5188 bar
M	=	25.00
EE	=	3000 Joule

**Verschiedene Daten**

Fe <sup>1)3)</sup>	=	0.10
delta L	=	

**PATRONENLAGER MINI**

<b>Längen</b>			
L1	=	35.00	
L2	=	36.40	
L3 <sup>1)</sup>	=	45.20	

**Stoßboden**

R	=		
R1	=	11.95	
R2	=		
R3	=		
r	=	1.00	

**Pulverkammer**

E	=	3.50	
P1 <sup>1)</sup>	=	11.95	
P2 *	=	11.80	

**Schulterkonus**

alpha <sup>1)</sup> *	=	25°	
S *	=	61.61	
r1 max	=	2.00	
r2	=	0.50	

**Hülsenhals**

H1 *	=	11.18	
H2 <sup>1)</sup>	=	11.15	

**Geschossübergang**

G1 <sup>1)</sup> *	=	10.58	
G <sup>1)</sup>	=	7.79	
alpha1	=	60°	
h	=	0.49	
s *	=	3.59	
i <sup>1)</sup> *	=	1°30'	
w	=		

**Lauf**

F <sup>1)</sup> *	=	10.36	
Z <sup>1)</sup>	=	10.57	

**Züge**

b	=	3.25	
N	=	6	
u	=	356.00	
Q	=	86.38	mm <sup>2</sup>

Bemerkungen: 1) Kontrolle aus Sicherheitsgründen  
3) Verschlussabstand an Schulter  
\* Grundmaße

<b>C.I.P.</b>	<b>416 Barrett</b> Ursprungsland: US	TAB. <b>I</b>
		Datum <b>16-05-18</b>
		Revision
Alternative Namen: 10,4 x 83		
	<b>PATRONE MAXI</b> <b>Längen</b> L1 <sup>1)</sup> = 63.74 -0.20 L2 <sup>1)</sup> = 71.15 -0.20 L3 <sup>1)</sup> = 83.06 L4 = L5 = L6 = 118.11 <b>Hülsenboden</b> R = 2.11 R1 = 20.42 R3 = E = 6.22 E1 = 17.27 e min = 1.96 delta = 36° f = 0.69 beta = 45° <b>Pulverkammer</b> P1 = 20.40 P2 <sup>1)</sup> * = 18.54 -0.20 <b>Schulterkonus</b> alpha * = 50° S * = 83.62 r1 min = r2 = <b>Hülsenhals</b> H1 * = 11.63 H2 <sup>1)</sup> = 11.63 <b>Geschoss</b> G1 <sup>1)</sup> = 10.57 G2 = F = L3+G <sup>1)</sup> = 92.15 <b>Drücke (Energien)</b> <b>Mech. elektr. Wandler</b> Pmax = 4400 bar PK = 5060 bar PE = 5500 bar M = 25.00 EE = 14250 Joule <b>Verschiedene Daten</b> Fe <sup>1)3)</sup> = 0.10 delta L = 0.10	<b>PATRONENLAGER MINI</b> <b>Längen</b> L1 = 63.61 L2 = 70.94 L3 <sup>1)</sup> = 83.44 <b>Stoßboden</b> R = R1 = 20.52 R2 = R3 = r = <b>Pulverkammer</b> E = 5.08 P1 <sup>1)</sup> = 20.45 P2 * = 18.57 <b>Schulterkonus</b> alpha <sup>1)</sup> * = 50° S * = 83.52 r1 max = r2 = <b>Hülsenhals</b> H1 * = 11.73 H2 <sup>1)</sup> = 11.68 <b>Geschossübergang</b> G1 <sup>1)</sup> * = 10.59 G <sup>1)</sup> = 9.09 alpha l = 30° h = 2.03 s * = 4.70 i <sup>1)</sup> * = 1°30' w = <b>Lauf</b> F <sup>1)</sup> * = 10.36 Z <sup>1)</sup> = 10.57 <b>Züge</b> b = 4.11 N = 6 u = 304.80 Q = 86.96 mm <sup>2</sup>
Maßstab 1:1.53		
Maße in << mm >> Maße und Toleranzen für Messläufe siehe Anhang CR1.	Bemerkungen: 1) Kontrolle aus Sicherheitsgründen 3) Verschlussabstand an Schulter * Grundmaße	

<b>C.I.P.</b>	<b>416 Rigby</b>		<b>TAB.</b>	<b>I</b>
	Ursprungsland: GB		Datum	84-06-14
			Revision	02-05-15
	<b>PATRONE MAXI</b>		<b>PATRONENLAGER MINI</b>	
	<p><b>Längen</b></p> <p>L1 <sup>1)</sup>* = 59.77 -0.20                  L2 <sup>1)</sup>* = 60.96 -0.20                  L3 <sup>1)</sup> = 73.66                  L4 =                  L5 =                  L6 = 95.25</p> <p><b>Hülsenboden</b></p> <p>R = 1.65                  R1 = 14.99                  R3 =                  E = 3.81                  E1 = 12.70                  e min = 0.81                  δ = 39°55'48"                  f =                  β =</p> <p><b>Pulverkammer</b></p> <p>P1 = 14.96                  P2 <sup>1)</sup>* = 13.72 -0.20</p> <p><b>Schulterkonus</b></p> <p>α = 89°45'32"                  S = 66.66                  r1 min =                  r2 =</p> <p><b>Hülsenhals</b></p> <p>H1 * = 11.35                  H2 <sup>1)</sup> = 11.33</p> <p><b>Geschoss</b></p> <p>G1 <sup>1)</sup> = 10.57                  G2 =                  F =                  L3+G <sup>1)</sup> = 81.28</p> <p><b>Drücke (Energien)</b></p> <p><b>Mech. elektr. Wandler</b></p> <p>Pmax = 3250 bar                  PK = 3738 bar                  PE = 4060 bar                  M = 25.00                  EE = 7270 Joule</p> <p><b>Verschiedene Daten</b></p> <p>Fe <sup>1)</sup> = 0.15                  delta L =</p>		<p><b>Längen</b></p> <p>L1 * = 59.72                  L2 * = 60.91                  L3 <sup>1)</sup> = 73.96</p> <p><b>Stoßboden</b></p> <p>R = 1.65                  R1 = 15.04                  R2 =                  R3 =                  r =</p> <p><b>Pulverkammer</b></p> <p>E = 3.81                  P1 <sup>1)</sup> = 14.99                  P2 * = 13.74</p> <p><b>Schulterkonus</b></p> <p>α <sup>1)</sup> = 89°30'59"                  S = 66.65                  r1 max =                  r2 =</p> <p><b>Hülsenhals</b></p> <p>H1 * = 11.38                  H2 <sup>1)</sup> = 11.35</p> <p><b>Geschossübergang</b></p> <p>G1 <sup>1)</sup>* = 10.59                  G <sup>1)</sup>* = 7.62                  α1 = 90°                  h * = 0.38                  s =                  i <sup>1)</sup> = 0°54'36"                  w =</p> <p><b>Lauf</b></p> <p>F <sup>1)</sup>* = 10.36                  Z <sup>1)</sup> = 10.57</p> <p><b>Züge</b></p> <p>b = 3.60                  N = 6                  u = 420.00                  Q = 86.61 mm<sup>2</sup></p>	
Maßstab 1:1.5  Maße in << mm >> Maße und Toleranzen für Messläufe siehe Anhang CR 1.		Bemerkungen: 1) Kontrolle aus Sicherheitsgründen * Grundmaße		

<b>C.I.P.</b>	<b>416 Ruger</b>		<b>TAB.</b>	<b>I</b>
	Ursprungsland: US		<b>Datum</b>	<b>10-05-26</b>
			<b>Revision</b>	
	<b>PATRONE MAXI</b>		<b>PATRONENLAGER MINI</b>	
	<p><b>Längen</b></p> <p>L1 <sup>1)</sup> = 55.37 -0.20                  L2 <sup>1)</sup> = 56.93 -0.20                  L3 <sup>1)</sup> = 65.53                  L4 =                  L5 =                  L6 = 84.84</p> <p><b>Hülsenboden</b></p> <p>R = 1.27                  R1 = 13.51                  R3 =                  E = 3.25                  E1 = 12.07                  e min = 0.94                  delta = 35°                  f = 0.38                  beta = 45°</p> <p><b>Pulverkammer</b></p> <p>P1 = 13.52                  P2 <sup>1)</sup>* = 13.08 -0.20</p> <p><b>Schulterkonus</b></p> <p>alpha * = 60°                  S * = 66.69                  r1 min = 0.76                  r2 = 3.18</p> <p><b>Hülsenhals</b></p> <p>H1 * = 11.28                  H2 <sup>1)</sup> = 11.25</p> <p><b>Geschoss</b></p> <p>G1 <sup>1)</sup> = 10.58                  G2 =                  F =                  L3+G <sup>1)</sup> = 75.38</p> <p><b>Drücke (Energien)</b></p> <p><b>Mech. elektr. Wandler</b></p> <p>Pmax = 4300 bar                  PK = 4945 bar                  PE = 5375 bar                  M = 25.00                  EE = 7275 Joule</p> <p><b>Verschiedene Daten</b></p> <p>Fe <sup>1)3)</sup> = 0.10                  delta L = 0.12</p>		<p><b>Längen</b></p> <p>L1 = 55.23                  L2 = 56.79                  L3 <sup>1)</sup> = 65.78</p> <p><b>Stoßboden</b></p> <p>R =                  R1 = 13.58                  R2 =                  R3 =                  r =</p> <p><b>Pulverkammer</b></p> <p>E = 3.25                  P1 <sup>1)</sup> = 13.54                  P2 * = 13.10</p> <p><b>Schulterkonus</b></p> <p>alpha <sup>1)</sup>* = 60°                  S * = 66.58                  r1 max = 0.76                  r2 = 3.18</p> <p><b>Hülsenhals</b></p> <p>H1 * = 11.30                  H2 <sup>1)</sup> = 11.28</p> <p><b>Geschossübergang</b></p> <p>G1 <sup>1)</sup>* = 10.59                  G <sup>1)</sup> = 9.85                  alpha l = 90°                  h = 0.34                  s * = 5.42                  i <sup>1)</sup>* = 1°30'                  w =</p> <p><b>Lauf</b></p> <p>F <sup>1)</sup>* = 10.36                  Z <sup>1)</sup> = 10.57</p> <p><b>Züge</b></p> <p>b = 3.25                  N = 6                  u = 356.00                  Q = 86.38 mm<sup>2</sup></p>	
<p>Maßstab 1:1.1</p> <p style="text-align: center;">Maße in &lt;&lt; mm &gt;&gt; Maße und Toleranzen für Messläufe siehe Anhang CR 1.</p>		<p>Bemerkungen: 1) Kontrolle aus Sicherheitsgründen                  3) Verschlussabstand an Schulter                  * Grundmaße</p>		



<b>C.I.P.</b>	<b>416 TYR</b> Ursprungsland: TR	<b>TAB.</b>	<b>I</b>
		<b>Datum</b>	<b>14-05-22</b>
		<b>Revision</b>	
	<p><b>PATRONE MAXI</b></p> <p><b>Längen</b></p> <p>L1 <sup>1)</sup> = 64.06 -0.20                  L2 <sup>1)</sup> = 69.00 -0.20                  L3 <sup>1)</sup> = 80.30                  L4 =                  L5 =                  L6 = 118.50</p> <p><b>Hülsenboden</b></p> <p>R = 2.00                  R1 = 17.78                  R3 =                  E = 5.31                  E1 = 15.00                  e min = 1.92                  delta = 45°                  f = 0.30                  beta = 45°</p> <p><b>Pulverkammer</b></p> <p>P1 = 17.78                  P2 <sup>1)</sup>* = 16.80 -0.20</p> <p><b>Schulterkonus</b></p> <p>alpha * = 56°                  S * = 79.86                  r1 min = 1.00                  r2 = 3.20</p> <p><b>Hülsenhals</b></p> <p>H1 * = 11.55                  H2 <sup>1)</sup> = 11.55</p> <p><b>Geschoss</b></p> <p>G1 <sup>1)</sup> = 10.57                  G2 =                  F =                  L3+G <sup>1)</sup> = 92.39</p> <p><b>Drücke (Energien)</b></p> <p><b>Mech. elektr. Wandler</b></p> <p>Pmax = 4400 bar                  PK = 5060 bar                  PE = 5500 bar                  M = 25.00                  EE = 10500 Joule</p> <p><b>Verschiedene Daten</b></p> <p>Fe <sup>1)3)</sup> = 0.10                  delta L =</p>	<p><b>PATRONENLAGER MINI</b></p> <p><b>Längen</b></p> <p>L1 = 64.03                  L2 = 68.95                  L3 <sup>1)</sup> = 80.80</p> <p><b>Stoßboden</b></p> <p>R =                  R1 = 17.83                  R2 =                  R3 =                  r =</p> <p><b>Pulverkammer</b></p> <p>E = 5.31                  P1 <sup>1)</sup> = 17.81                  P2 * = 16.83</p> <p><b>Schulterkonus</b></p> <p>alpha <sup>1)</sup>* = 56°                  S * = 79.86                  r1 max = 1.00                  r2 = 3.50</p> <p><b>Hülsenhals</b></p> <p>H1 * = 11.60                  H2 <sup>1)</sup> = 11.58</p> <p><b>Geschossübergang</b></p> <p>G1 <sup>1)</sup>* = 10.59                  G <sup>1)</sup> = 12.09                  alpha1 = 90°                  h = 0.50                  s * = 5.50                  i <sup>1)</sup>* = 1°                  w =</p> <p><b>Lauf</b></p> <p>F <sup>1)</sup>* = 10.36                  Z <sup>1)</sup> = 10.57</p> <p><b>Züge</b></p> <p>b = 3.25                  N = 6                  u = 330.20                  Q = 86.38 mm<sup>2</sup></p>	
			<p>Maßstab 1:1.46</p> <p>Maße in &lt;&lt; mm &gt;&gt;                  Maße und Toleranzen für Messläufe                  siehe Anhang CR1.</p>

<b>C.I.P.</b>	<b>45 Blaser</b>		<b>TAB.</b>	<b>I</b>
	Ursprungsland: DE		<b>Datum</b>	<b>02-10-21</b>
			<b>Revision</b>	<b>05-12-07</b>
	<b>PATRONE MAXI</b>		<b>PATRONENLAGER MINI</b>	
	<p><b>Längen</b></p> <p>L1 <sup>1)</sup>* = 40.74 -0.20                  L2 <sup>1)</sup>* = 42.50 -0.20                  L3 <sup>1)</sup> = 55.00                  L4 =                  L5 =                  L6 = 68.50</p> <p><b>Hülsenboden</b></p> <p>R = 1.37                  R1 = 12.01                  R3 =                  E = 4.39                  E1 = 10.39                  e min = 1.20                  delta = 36°                  f = 0.38                  beta = 35°</p> <p><b>Pulverkammer</b></p> <p>P1 = 13.03                  P2 <sup>1)</sup>* = 12.98 -0.20</p> <p><b>Schulterkonus</b></p> <p>alpha = 19°58'44"                  S = 77.59                  r1 min = 0.50                  r2 = 0.50</p> <p><b>Hülsenhals</b></p> <p>H1* = 12.36                  H2 <sup>1)</sup> = 12.36</p> <p><b>Geschoss</b></p> <p>G1 <sup>1)</sup> = 11.64                  G2 =                  F =                  L3+G <sup>1)</sup> = 59.19</p> <p><b>Drücke (Energien)</b></p> <p><b>Mech. elektr. Wandler</b></p> <p>Pmax = 3700 bar                  PK = 4255 bar                  PE = 4625 bar                  M = 25.00                  EE = 4650 Joule</p> <p><b>Verschiedene Daten</b></p> <p>Fe = 0.15                  delta L =</p>		<p><b>Längen</b></p> <p>L1* = 40.66                  L2* = 42.42                  L3 <sup>1)</sup> = 55.25</p> <p><b>Stoßboden</b></p> <p>R =                  R1 = 12.03                  R2 =                  R3 =                  r =</p> <p><b>Pulverkammer</b></p> <p>E = 4.41                  P1 <sup>1)</sup> = 13.08                  P2* = 13.02</p> <p><b>Schulterkonus</b></p> <p>alpha <sup>1)</sup> = 19°58'44"                  S = 77.62                  r1 max = 0.50                  r2 = 0.50</p> <p><b>Hülsenhals</b></p> <p>H1* = 12.40                  H2 <sup>1)</sup> = 12.38</p> <p><b>Geschossübergang</b></p> <p>G1 <sup>1)</sup>* = 11.66                  G <sup>1)</sup>* = 4.19                  alpha1 = 90°                  h = 0.36                  s* = 2.00                  i <sup>1)</sup> = 3°00'21"                  w =</p> <p><b>Lauf</b></p> <p>F <sup>1)</sup>* = 11.43                  Z <sup>1)</sup> = 11.63</p> <p><b>Züge</b></p> <p>b = 3.81                  N = 6                  u = 356.00                  Q = 104.94 mm<sup>2</sup></p>	
Maßstab 1:1				
Maße in << mm >> Maße und Toleranzen für Messläufe siehe Anhang CR 1.		Bemerkungen: 1) Kontrolle aus Sicherheitsgründen * Grundmaße		

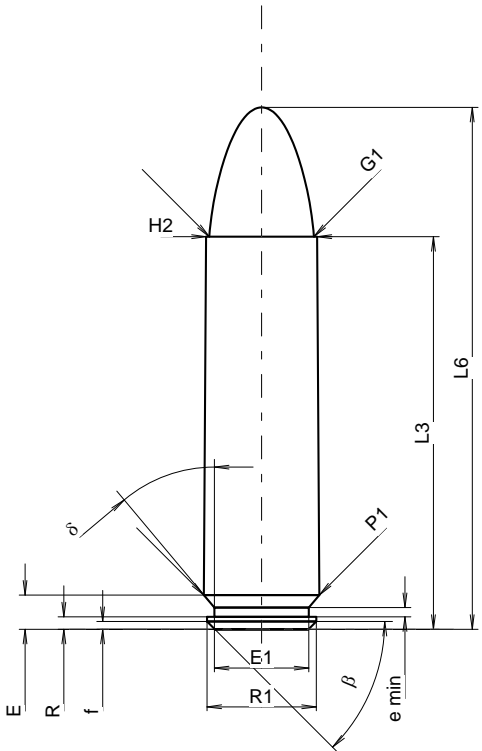
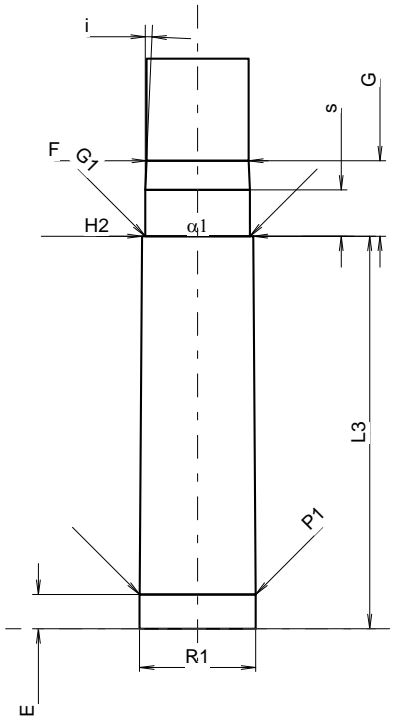
C.I.P.	450 Bushmaster		TAB.	I
			Datum	10-05-26
	Ursprungsland: US		Revision	
	<b>PATRONE MAXI</b>		<b>PATRONENLAGER MINI</b>	
	<b>Längen</b> L1 = L2 = L3 <sup>1)</sup> = 43.18 -0.25 L4 = L5 = L6 = 57.40  <b>Hülsenboden</b> R = 1.37 R1 = 12.01 R3 = E = 3.77 E1 = 10.39 e min = 1.02 δ = 40° f = 0.86 β = 45°  <b>Pulverkammer</b> P1 = 12.70 P2 =  <b>Schulterkonus</b> α = S = r1 min = r2 =  <b>Hülsenhals</b> H1 = H2 <sup>1)</sup> = 12.19  <b>Geschoss</b> G1 <sup>1)</sup> = 11.49 G2 = F = L3+G <sup>1)</sup> = 51.47  <b>Drücke (Energien)</b> <b>Mech. elektr. Wandler</b> Pmax = 2700 bar PK = 3105 bar PE = 3375 bar M = 25.00 EE = 3950 Joule  <b>Verschiedene Daten</b> Fe <sup>1)6)</sup> = 0.15 delta L =		<b>Längen</b> L1 = L2 = L3 <sup>1)</sup> = 43.18  <b>Stoßboden</b> R = R1 = 12.79 R2 = R3 = r =  <b>Pulverkammer</b> E = 3.77 P1 <sup>1)</sup> = 12.75 P2 =  <b>Schulterkonus</b> α = S = r1 max = r2 =  <b>Hülsenhals</b> H1 = H2 <sup>1)</sup> = 12.22  <b>Geschossübergang</b> G1 <sup>1)</sup> * = 11.51 G <sup>1)</sup> = 8.29 α1 = 180° h = s* = 5.08 i <sup>1)</sup> * = 2°30' w =  <b>Lauf</b> F <sup>1)</sup> * = 11.23 Z <sup>1)</sup> = 11.43  <b>Züge</b> b = 3.76 N = 6 u = 609.60 Q = 101.35 mm <sup>2</sup>	
	Maßstab 1.2:1  Maße in << mm >> Maße und Toleranzen für Messläufe siehe Anhang CR 1.			
		Bemerkungen: 1) Kontrolle aus Sicherheitsgründen 6) Verschlussabstand an Hülsenmund * Grundmaße		

<b>C.I.P.</b>	<b>450 Rigby</b>		<b>TAB.</b>	<b>I</b>
	Ursprungsland: GB		<b>Datum</b>	<b>00-02-15</b>
			<b>Revision</b>	<b>07-05-14</b>
	<b>PATRONE MAXI</b>		<b>PATRONENLAGER MINI</b>	
	<p><b>Längen</b></p> <p>L1 * = 59.50 -0.20                      L2 * = 60.69 -0.20                      L3 <sup>1)</sup> = 73.50                      L4 =                      L5 =                      L6 = 95.25</p> <p><b>Hülsenboden</b></p> <p>R = 1.65                      R1 = 14.99                      R3 =                      E = 3.81                      E1 = 12.70                      e min = 0.81                      δ = 39°55'50"                      f =                      β =</p> <p><b>Pulverkammer</b></p> <p>P1 = 14.96                      P2 <sup>1)</sup>* = 14.50 -0.20</p> <p><b>Schulterkonus</b></p> <p>α = 80°04'59"                      S = 68.13                      r1 min =                      r2 =</p> <p><b>Hülsenhals</b></p> <p>H1 * = 12.50                      H2 <sup>1)</sup> = 12.38</p> <p><b>Geschoss</b></p> <p>G1 <sup>1)</sup> = 11.66                      G2 =                      F =                      L3+G <sup>1)</sup> = 81.89</p> <p><b>Drücke (Energien)</b></p> <p><b>Mech. elektr. Wandler</b></p> <p>Pmax = 4000 bar                      PK = 4600 bar                      PE = 5000 bar                      M = 25.00                      EE = 8715 Joule</p> <p><b>Verschiedene Daten</b></p> <p>Fe <sup>1)3)</sup> = 0.10                      delta L =</p>		<p><b>Längen</b></p> <p>L1 * = 59.48                      L2 * = 60.67                      L3 <sup>1)</sup> = 73.80</p> <p><b>Stoßboden</b></p> <p>R = 1.65                      R1 = 15.04                      R2 =                      R3 =                      r =</p> <p><b>Pulverkammer</b></p> <p>E = 3.81                      P1 <sup>1)</sup> = 14.99                      P2 * = 14.53</p> <p><b>Schulterkonus</b></p> <p>α <sup>1)</sup> = 80°04'59"                      S = 68.13                      r1 max =                      r2 =</p> <p><b>Hülsenhals</b></p> <p>H1 * = 12.53                      H2 <sup>1)</sup> = 12.41</p> <p><b>Geschossübergang</b></p> <p>G1 <sup>1)</sup>* = 11.68                      G <sup>1)</sup>* = 8.39                      α1 = 89°13'14"                      h = 0.37                      s * = 6.00                      i <sup>1)</sup> = 2°59'38"                      w =</p> <p><b>Lauf</b></p> <p>F <sup>1)</sup>* = 11.43                      Z <sup>1)</sup> = 11.63</p> <p><b>Züge</b></p> <p>b = 3.60                      N = 6                      u = 420.00                      Q = 104.80 mm<sup>2</sup></p>	
<p>Maßstab 1:1.17</p> <p>Maße in &lt;&lt; mm &gt;&gt;                      Maße und Toleranzen für Messläufe                      siehe Anhang CR 1.</p>		<p>Bemerkungen: 1) Kontrolle aus Sicherheitsgründen                      3) Verschlussabstand an Schulter                      * Grundmaße</p>		

<b>C.I.P.</b>	<b>460 Steyr</b>		<b>TAB. I</b>
	Ursprungsland: AT		<b>Datum 06-05-16</b>
			<b>Revision</b>
	<b>PATRONE MAXI</b>		<b>PATRONENLAGER MINI</b>
	<p><b>Längen</b></p> <p>L1<sup>1)</sup> = 71.40 -0.20                  L2<sup>1)</sup> = 76.53 -0.20                  L3<sup>1)</sup> = 90.00                  L4 =                  L5 =                  L6 = 140.00</p> <p><b>Hülsenboden</b></p> <p>R = 2.26                  R1 = 20.42                  R3 =                  E = 6.23                  E1 = 17.27                  e min = 1.80                  delta = 36°                  f = 0.84                  beta = 45°</p> <p><b>Pulverkammer</b></p> <p>P1 = 20.42                  P2<sup>1)*</sup> = 18.25 -0.20</p> <p><b>Schulterkonus</b></p> <p>alpha* = 56°38'53"                  S* = 88.33                  r1 min = 1.00                  r2 = 3.00</p> <p><b>Hülsenhals</b></p> <p>H1* = 12.72                  H2<sup>1)</sup> = 12.72</p> <p><b>Geschoss</b></p> <p>G1<sup>1)*</sup> = 11.65                  G2 =                  F* = 11.43                  L3+G<sup>1)</sup> = 105.30</p> <p><b>Drücke (Energien)</b></p> <p><b>Mech. elektr. Wandler</b></p> <p>Pmax = 3700 bar                  PK = 4255 bar                  PE = 4625 bar                  M = 40.00                  EE = 15000 Joule</p> <p><b>Verschiedene Daten</b></p> <p>Fe<sup>1)</sup> = 0.15                  delta L =</p>		<p><b>Längen</b></p> <p>L1 = 71.43                  L2 = 76.56                  L3<sup>1)</sup> = 91.00</p> <p><b>Stoßboden</b></p> <p>R =                  R1 = 20.52                  R2 =                  R3 =                  r =</p> <p><b>Pulverkammer</b></p> <p>E = 6.23                  P1<sup>1)</sup> = 20.45                  P2* = 18.30</p> <p><b>Schulterkonus</b></p> <p>alpha<sup>1)*</sup> = 55°57'13"                  S* = 88.66                  r1 max = 1.00                  r2 = 3.00</p> <p><b>Hülsenhals</b></p> <p>H1* = 12.85                  H2<sup>1)</sup> = 12.75</p> <p><b>Geschossübergang</b></p> <p>G1<sup>1)*</sup> = 11.65                  G<sup>1)</sup> = 15.30                  alpha1 = 90°                  h = 0.55                  s* = 6.50                  i<sup>1)*</sup> = 0°42'58"                  w =</p> <p><b>Lauf</b></p> <p>F<sup>1)*</sup> = 11.43                  Z<sup>1)</sup> = 11.63</p> <p><b>Züge</b></p> <p>b = 3.81                  N = 6                  u = 356.00                  Q = 104.94 mm<sup>2</sup></p>
Maßstab 1:2			
Maße in << mm >> Maße und Toleranzen für Messläufe siehe Anhang CR 1.	Bemerkungen: 1) Kontrolle aus Sicherheitsgründen * Grundmaße		

<b>C.I.P.</b>	<b>50 Browning</b>		TAB.	I
			Datum	95-05-31
	Ursprungsland: US		Revision	10-05-26
Alternative Namen: 12,7 x 99				
	<b>PATRONE MAXI</b>		<b>PATRONENLAGER MINI</b>	
	<b>Längen</b> L1 <sup>1)</sup> = 76.34 -0.20 L2 <sup>1)</sup> = 83.30 -0.20 L3 <sup>1)</sup> = 99.31 L4 = L5 = L6 = 138.43  <b>Hülsenboden</b> R = 2.26 R1 = 20.42 R3 = E = 6.23 E1 = 17.27 e min = 1.80 δ = 36° f = 0.84 β = 45°  <b>Pulverkammer</b> P1 = 20.42 P2 <sup>1)</sup> * = 18.14 -0.20  <b>Schulterkonus</b> α <sup>*</sup> = 31°28' S <sup>*</sup> = 108.54 r1 min = r2 =  <b>Hülsenhals</b> H1 <sup>*</sup> = 14.22 H2 <sup>1)</sup> = 14.22  <b>Geschoss</b> G1 <sup>1)</sup> * = 12.98 G2 = F = L3+G <sup>1)</sup> = 132.50  <b>Drücke (Energien)</b> <b>Mech. elektr. Wandler</b> Pmax = 3700 bar PK = 4255 bar PE = 4625 bar M = 25.00 EE = 15000 Joule  <b>Verschiedene Daten</b> Fe <sup>1)3)</sup> = 0.15 delta L = 0.28		<b>Längen</b> L1 = 76.02 L2 = 82.82 L3 <sup>1)</sup> = 99.70  <b>Stoßboden</b> R = R1 = 20.52 R2 = R3 = r =  <b>Pulverkammer</b> E = 5.08 P1 <sup>1)</sup> = 20.45 P2 <sup>*</sup> = 18.16  <b>Schulterkonus</b> α <sup>1)</sup> * = 31°28' S <sup>*</sup> = 108.25 r1 max = r2 =  <b>Hülsenhals</b> H1 <sup>*</sup> = 14.33 H2 <sup>1)</sup> = 14.28  <b>Geschossübergang</b> G1 <sup>1)</sup> * = 13.16 G <sup>1)</sup> = 33.19 α1 = 30° h = 2.09 s = 8.64 i <sup>1)</sup> * = 0°34'59" w =  <b>Lauf</b> F <sup>1)</sup> * = 12.66 Z <sup>1)</sup> = 12.93  <b>Züge</b> b = 3.43 N = 8 u = 381.00 Q = 129.63 mm <sup>2</sup>	
	Maßstab 1:1.86  Maße in << mm >> Maße und Toleranzen für Messläufe siehe Anhang CR 1.			
Bemerkungen: 1) Kontrolle aus Sicherheitsgründen 3) Verschlussabstand an Schulter * Grundmaße				

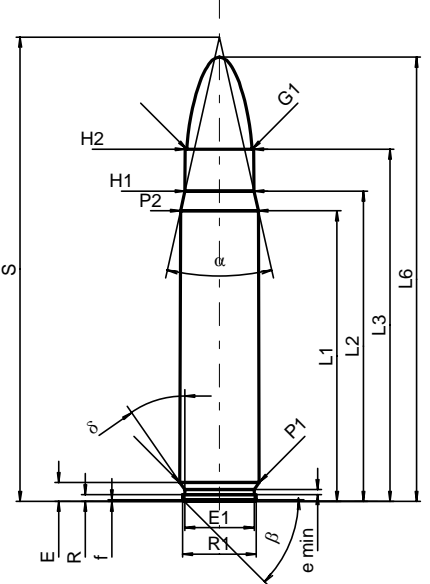
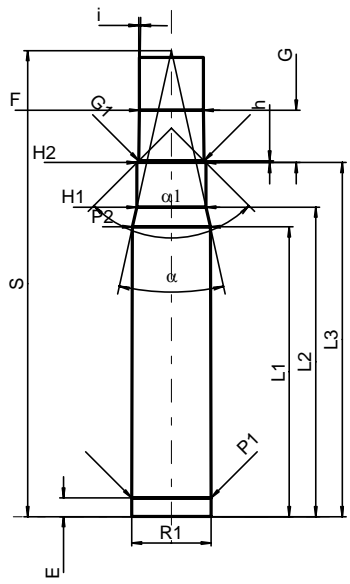
<b>C.I.P.</b>	<b>500 Jeffery</b>		<b>TAB. I</b>
	Ursprungsland: GB		<b>Datum 99-01-12</b>
			<b>Revision 02-05-15</b>
	<b>PATRONE MAXI</b>		<b>PATRONENLAGER MINI</b>
	<p><b>Längen</b></p> <p>L1 <sup>1)</sup>* = 57.61 -0.20                  L2 <sup>1)</sup>* = 61.52 -0.20                  L3 <sup>1)</sup> = 69.85                  L4 =                  L5 =                  L6 = 88.09</p> <p><b>Hülsenboden</b></p> <p>R = 1.32                  R1 = 14.61                  R3 =                  E = 3.73                  E1 = 13.77                  e min = 1.00                  delta = 34°39'36"                  f = 0.30                  beta = 45°</p> <p><b>Pulverkammer</b></p> <p>P1 = 15.72                  P2 <sup>1)</sup>* = 15.42 -0.20</p> <p><b>Schulterkonus</b></p> <p>alpha = 25°13'42"                  S = 92.06                  r1 min =                  r2 =</p> <p><b>Hülsenhals</b></p> <p>H1 * = 13.67                  H2 <sup>1)</sup> = 13.61</p> <p><b>Geschoss</b></p> <p>G1 <sup>1)</sup> = 12.95                  G2 =                  F =                  L3+G <sup>1)</sup> = 80.26</p> <p><b>Drücke (Energien)</b></p> <p><b>Mech. elektr. Wandler</b></p> <p>Pmax = 3300 bar                  PK = 3795 bar                  PE = 4125 bar                  M = 25.00                  EE = 9660 Joule</p> <p><b>Verschiedene Daten</b></p> <p>Fe <sup>1)</sup> = 0.15                  delta L =</p>		<p><b>Längen</b></p> <p>L1 * = 57.48                  L2 * = 61.39                  L3 <sup>1)</sup> = 70.23</p> <p><b>Stoßboden</b></p> <p>R = 1.32                  R1 = 15.77                  R2 =                  R3 =                  r =</p> <p><b>Pulverkammer</b></p> <p>E = 3.73                  P1 <sup>1)</sup> = 15.77                  P2 * = 15.47</p> <p><b>Schulterkonus</b></p> <p>alpha <sup>1)</sup> = 24°56'56"                  S = 92.44                  r1 max =                  r2 =</p> <p><b>Hülsenhals</b></p> <p>H1 * = 13.74                  H2 <sup>1)</sup> = 13.69</p> <p><b>Geschossübergang</b></p> <p>G1 <sup>1)</sup>* = 12.98                  G <sup>1)</sup>* = 10.41                  alpha1 = 90°                  h * = 0.36                  s =                  i <sup>1)</sup> = 0°47'53"                  w =</p> <p><b>Lauf</b></p> <p>F <sup>1)</sup>* = 12.70                  Z <sup>1)</sup> = 12.97</p> <p><b>Züge</b></p> <p>b = 4.45                  N = 6                  u = 508.00                  Q = 130.36 mm<sup>2</sup></p>
			
Maßstab 1:1.5			
Maße in << mm >> Maße und Toleranzen für Messläufe siehe Anhang CR 1.	Bemerkungen: 1) Kontrolle aus Sicherheitsgründen * Grundmaße		

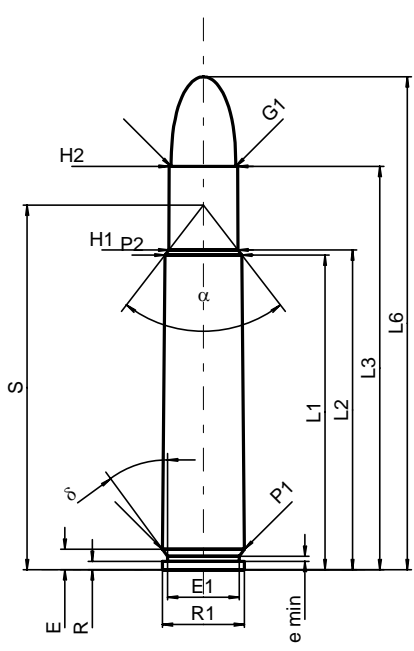
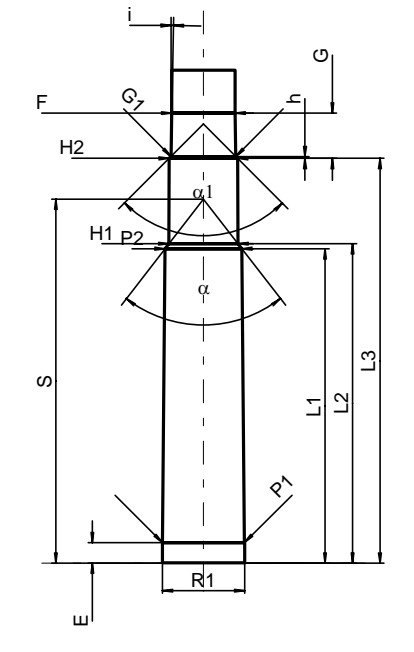
<b>C.I.P.</b>	<b>505 Mag. Gibbs</b>		<b>TAB.</b>	<b>I</b>
	Ursprungsland: GB		Datum	84-06-14
			Revision	02-05-15
	<b>PATRONE MAXI</b>		<b>PATRONENLAGER MINI</b>	
	<p><b>Längen</b></p> <p>L1 <sup>1)</sup>* = 62.43 -0.20                  L2 <sup>1)</sup>* = 63.45 -0.20                  L3 <sup>1)</sup> = 80.01                  L4 =                  L5 =                  L6 = 97.79</p> <p><b>Hülsenboden</b></p> <p>R = 1.65                  R1 = 16.26                  R3 =                  E = 4.06                  E1 = 14.22                  e min = 1.02                  delta = 36°18'36"                  f =                  beta =</p> <p><b>Pulverkammer</b></p> <p>P1 = 16.26                  P2 <sup>1)</sup>* = 15.24 -0.20</p> <p><b>Schulterkonus</b></p> <p>alpha = 75°09'51"                  S = 72.33                  r1 min =                  r2 =</p> <p><b>Hülsenhals</b></p> <p>H1 * = 13.67                  H2 <sup>1)</sup> = 13.59</p> <p><b>Geschoss</b></p> <p>G1 <sup>1)</sup> = 12.83                  G2 =                  F =                  L3+G <sup>1)</sup> = 88.98</p> <p><b>Drücke (Energien)</b></p> <p><b>Mech. elektr. Wandler</b></p> <p>Pmax = 2700 bar                  PK = 3105 bar                  PE = 3375 bar                  M = 25.00                  EE = 7040 Joule</p> <p><b>Verschiedene Daten</b></p> <p>Fe <sup>1)</sup> = 0.15                  delta L =</p>		<p><b>Längen</b></p> <p>L1 * = 62.38                  L2 * = 63.40                  L3 <sup>1)</sup> = 80.31</p> <p><b>Stoßboden</b></p> <p>R = 1.65                  R1 = 16.31                  R2 =                  R3 =                  r =</p> <p><b>Pulverkammer</b></p> <p>E = 4.06                  P1 <sup>1)</sup> = 16.28                  P2 * = 15.27</p> <p><b>Schulterkonus</b></p> <p>alpha <sup>1)</sup> = 75°30'59"                  S = 72.24                  r1 max =                  r2 =</p> <p><b>Hülsenhals</b></p> <p>H1 * = 13.69                  H2 <sup>1)</sup> = 13.61</p> <p><b>Geschossübergang</b></p> <p>G1 <sup>1)</sup>* = 12.85                  G <sup>1)</sup>* = 8.97                  alpha1 = 90°                  h * = 0.38                  s =                  i <sup>1)</sup> = 1°00'11"                  w =</p> <p><b>Lauf</b></p> <p>F <sup>1)</sup>* = 12.55                  Z <sup>1)</sup> = 12.80</p> <p><b>Züge</b></p> <p>b = 5.33                  N = 5                  u = 406.00                  Q = 127.14 mm<sup>2</sup></p>	
				
Maßstab 1:1.5				
Maße in << mm >> Maße und Toleranzen für Messläufe siehe Anhang CR 1.		Bemerkungen: 1) Kontrolle aus Sicherheitsgründen * Grundmaße		



C.I.P.	510 DTC		TAB.	I
	Ursprungsland: GB		Datum	04-05-18
			Revision	04-09-27
	<b>PATRONE MAXI</b> <b>Längen</b> L1 <sup>1)</sup> * = 72.04 -0.20 L2 <sup>1)</sup> * = 79.48 -0.20 L3 <sup>1)</sup> = 96.14 L4 = L5 = L6 = 137.47 <b>Hülsenboden</b> R = 2.26 R1 = 20.42 R3 = E = 6.20 E1 = 17.27 e min = 1.80 delta = 36° f = 0.84 beta = 45° <b>Pulverkammer</b> P1 = 20.38 P2 <sup>1)</sup> * = 19.28 -0.20 <b>Schulterkonus</b> alpha = 37°33'42" S = 100.39 r1 min = 3.18 r2 = 5.08 <b>Hülsenhals</b> H1* = 14.22 H2 <sup>1)</sup> = 14.22 <b>Geschoss</b> G1 <sup>1)</sup> = 12.98 G2 = F = L3+G <sup>1)</sup> = 108.53 <b>Drücke (Energien)</b> <b>Mech. elektr. Wandler</b> Pmax = 3600 bar PK = 4140 bar PE = 4500 bar M = 25.00 EE = 14870 Joule <b>Verschiedene Daten</b> Fe = 0.15 delta L =		<b>PATRONELAGER MINI</b> <b>Längen</b> L1* = 72.21 L2* = 79.73 L3 <sup>1)</sup> = 96.52 <b>Stoßboden</b> R = 2.26 R1 = 20.52 R2 = R3 = r = <b>Pulverkammer</b> E = 7.62 P1 <sup>1)</sup> = 20.37 P2* = 19.31 <b>Schulterkonus</b> alpha <sup>1)</sup> = 36°38'28" S = 101.37 r1 max = 3.18 r2 = 6.35 <b>Hülsenhals</b> H1* = 14.33 H2 <sup>1)</sup> = 14.28 <b>Geschossübergang</b> G1 <sup>1)</sup> * = 12.99 G <sup>1)</sup> * = 12.39 alpha1 = 29°57'59" h = 2.41 s* = 5.72 i <sup>1)</sup> = 1°25'01" w = <b>Lauf</b> F <sup>1)</sup> * = 12.66 Z <sup>1)</sup> = 12.93 <b>Züge</b> b = 3.43 N = 8 u = 381.00 Q = 129.63 mm <sup>2</sup>	
		Maßstab 1:2  Maße in << mm >> Maße und Toleranzen für Messläufe siehe Anhang CR 1.		
Bemerkungen: 1) Kontrolle aus Sicherheitsgründen * Grundmaße				

