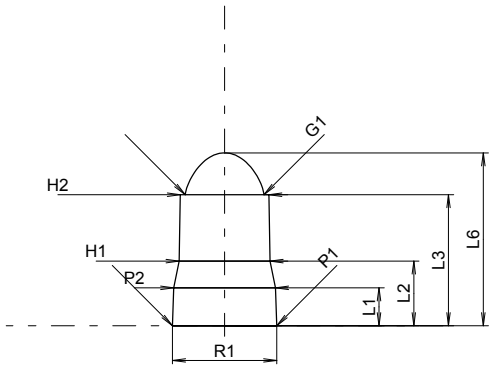
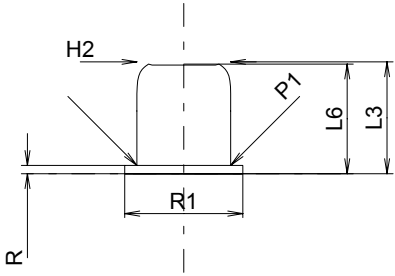
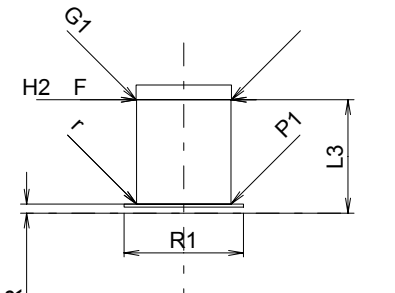
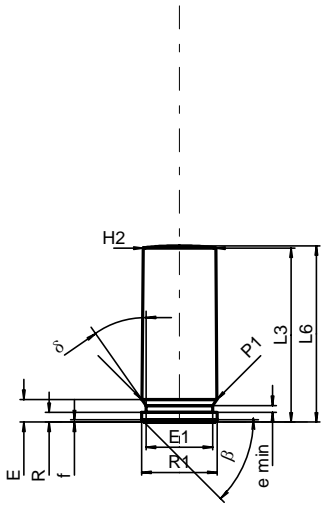
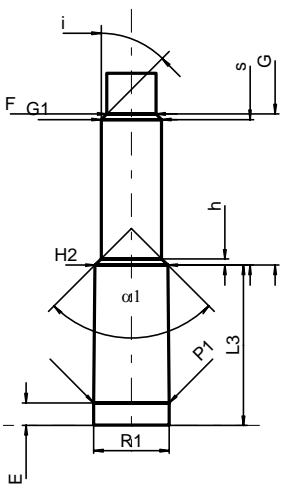

C.I.P.	4mm M 20 Ursprungsland: DE	TAB.	X
		Datum	07-05-14
		Revision	
	PATRONE MAXI	PATRONENLAGER MINI	
	<p>Längen</p> <p>L1 = 2.08 L2 = 3.55 L3 = 7.20 L4 = L5 = L6 = 9.50</p> <p>Hülsenboden</p> <p>R = R1 = 5.73 R3 = E = E1 = e min = δ = f = β =</p> <p>Pulverkammer</p> <p>P1 = 5.73 P2 = 5.60</p> <p>Schulterkonus</p> <p>α = S = r1 min = r2 =</p> <p>Hülsenhals</p> <p>H1 = 5.00 H2 = 4.87</p> <p>Geschoss</p> <p>G1 = 4.33 G2 = F = L3+G =</p> <p>Drücke (Energien)</p> <p>Energie</p> <p>E_{max} = 7.5 Joule E_K = 8.0 Joule E_E = 8.3 Joule</p> <p>Verschiedene Daten</p> <p>Fe = delta L =</p>	<p>Längen</p> <p>L1 = 2.03 L2 = 3.50 L3 = 7.40</p> <p>Stoßboden</p> <p>R = R1 = 5.73 R2 = R3 = r =</p> <p>Pulverkammer</p> <p>E = P1 = 5.73 P2 = 5.60</p> <p>Schulterkonus</p> <p>α = 23° S = r1 max = r2 =</p> <p>Hülsenhals</p> <p>H1 = 5.00 H2 = 4.90</p> <p>Geschossübergang</p> <p>G1 = 4.90 G = 0.48 α1 = h = s = i = 40° w =</p> <p>Lauf</p> <p>F = 4.10 Z = 4.28</p> <p>Züge</p> <p>b = N = u = Q = mm²</p>	
<p>Maßstab 2.41:1</p> <p style="text-align: center;">Maße in << mm >> Maße und Toleranzen für Messläufe siehe Anhang .</p>	<p>Bemerkungen:</p>		

C.I.P.	6,2/7 Ursprungsland: FR	TAB.	X
		Datum	01-04-24
		Revision	02-05-15
	<p align="center">PATRONE MAXI</p> <p>Längen</p> L1 = L2 = L3 ¹⁾ = 7.40 L4 = L5 = L6 ¹⁾ = 7.25 <p>Hülsenboden</p> R = 0.55 R1 = 7.80 R3 = E = E1 = e min = δ = f = β = <p>Pulverkammer</p> P1 = 6.20 P2 = <p>Schulterkonus</p> α = S = r1 min = r2 = <p>Hülsenhals</p> H1 = H2 ¹⁾ = 6.20 <p>Geschoß</p> G1 = G2 = F = L3+G = <p>Drücke (Energien)</p> Energie E _{max} = 60.0 Joule E _K = 64.0 Joule E _E = 66.0 Joule <p>Verschiedene Daten</p> Fe = delta L =	<p align="center">PATRONENLAGER MINI</p> <p>Längen</p> L1 = L2 = L3 ¹⁾ = 7.50 +0.10 <p>Stossboden</p> R ¹⁾ = 0.60 R1 = 7.90 R2 = R3 = r = 0.30 <p>Pulverkammer</p> E = P1 ¹⁾ = 6.25 P2 = <p>Schulterkonus</p> α = S = r1 max = r2 = <p>Hülsenhals</p> H1 = H2 ¹⁾ = 6.25 <p>Übergang</p> G1 * = 6.30 G = α1 = h = s = i = w = <p>Lauf</p> F * = 6.30 Z = <p>Züge</p> b = N = u = Q = mm ²	
			
<p>Maßstab 2:1</p> <p align="center">Maße in << mm >> Maße und Toleranzen für Messläufe siehe Anhang CR 5.</p>	<p>Bemerkungen: 1) Kontrolle aus Sicherheitsgründen * Grundmaße</p>		

C.I.P.	8,8 x 10 S.A.P.L. Ursprungsland: FR	TAB.	X
		Datum	96-03-05
		Revision	04-05-18
	<p>PATRONE MAXI</p> <p>Längen</p> <p>L1 =</p> <p>L2 =</p> <p>L3¹⁾ = 10.85</p> <p>L4 =</p> <p>L5 =</p> <p>L6 = 15.80</p> <p>Hülsenboden</p> <p>R = 1.50</p> <p>R1 = 11.18</p> <p>R3 =</p> <p>E =</p> <p>E1 =</p> <p>e min =</p> <p>delta =</p> <p>f = 0.38</p> <p>beta = 35°</p> <p>Pulverkammer</p> <p>P1 = 9.63</p> <p>P2 =</p> <p>Schulterkonus</p> <p>alpha =</p> <p>S =</p> <p>r1 min =</p> <p>r2 =</p> <p>Hülsenhals</p> <p>H1 =</p> <p>H2 =</p> <p>Geschoss</p> <p>G1 = 8.80</p> <p>G2 = 8.43</p> <p>G3 = 8.49</p> <p>Höhe des Geschosses</p> <p>L7 = 8.10</p> <p>Energie</p> <p>E_{max} = 6.0 Joule</p> <p>E_K = 6.4 Joule</p> <p>E_E = 6.6 Joule</p>	<p>PATRONENLAGER MINI</p> <p>Längen</p> <p>L1¹⁾ = 8.90</p> <p>L2 =</p> <p>L3 =</p> <p>Stoßboden</p> <p>R =</p> <p>R1 =</p> <p>R2 =</p> <p>R3 =</p> <p>r =</p> <p>Pulverkammer</p> <p>E =</p> <p>P1¹⁾ = 9.63</p> <p>P2 =</p> <p>Schulterkonus</p> <p>alpha =</p> <p>S =</p> <p>r1 max =</p> <p>r2 =</p> <p>Hülsenhals</p> <p>H1 =</p> <p>H2 =</p> <p>Übergang</p> <p>G1 =</p> <p>G =</p> <p>alpha1 =</p> <p>h =</p> <p>s =</p> <p>i =</p> <p>w =</p> <p>Lauf</p> <p>F =</p> <p>Z =</p>	
<p>Maßstab 2:1</p>			
<p>Dimensionen in « mm » Dimensionen und Toleranzen für Messläufe siehe Anhang: CR 2</p>		<p>Bemerkungen: 1 Kontrolle aus Sicherheitsgründen * Grundmaße</p>	

C.I.P.	10 x 23 T		TAB. X
	Ursprungsland: RU		Datum 05-05-25
			Revision
	PATRONE MAXI		PATRONENLAGER MINI
	<p>Längen</p> <p>L1 =</p> <p>L2 = 22.70</p> <p>L3 ¹⁾ = 23.00</p> <p>L4 =</p> <p>L5 =</p> <p>L6 ¹⁾ = 23.30</p> <p>Hülsenboden</p> <p>R = 1.27</p> <p>R1 = 9.96</p> <p>R3 =</p> <p>E = 2.98</p> <p>E1 = 8.79</p> <p>e min = 0.90</p> <p>delta = 35°</p> <p>f = 0.30</p> <p>beta = 45°</p> <p>Pulverkammer</p> <p>P1 = 9.93</p> <p>P2 =</p> <p>Schulterkonus</p> <p>alpha =</p> <p>S =</p> <p>r1 min =</p> <p>r2 =</p> <p>Hülsenhals</p> <p>H1 =</p> <p>H2 ¹⁾ = 9.62</p> <p>Geschoss</p> <p>G1 =</p> <p>G2 =</p> <p>F =</p> <p>L3+G ¹⁾ = 43.00</p> <p>Drücke (Energien)</p> <p>Fe =</p> <p>delta L =</p>		<p>Längen</p> <p>L1 =</p> <p>L2 =</p> <p>L3 ¹⁾ = 21.20</p> <p>Stoßboden</p> <p>R =</p> <p>R1 = 10.00</p> <p>R2 =</p> <p>R3 =</p> <p>r =</p> <p>Pulverkammer</p> <p>E = 2.98</p> <p>P1 ¹⁾ = 9.98</p> <p>P2 =</p> <p>Schulterkonus</p> <p>alpha =</p> <p>S =</p> <p>r1 max =</p> <p>r2 =</p> <p>Hülsenhals</p> <p>H1 =</p> <p>H2 ¹⁾ = 9.65</p> <p>Geschossübergang</p> <p>G1 = 8.00</p> <p>G = 20.00</p> <p>alpha1 = 90°</p> <p>h = 0.82</p> <p>s = 19.25</p> <p>i = 45°</p> <p>w =</p> <p>Lauf</p> <p>F = 6.50</p> <p>Z =</p> <p>Züge</p> <p>b =</p> <p>N =</p> <p>u =</p> <p>Q = 33.17 mm²</p>
	<p>Maßstab 1:1</p> <p>Maße in << mm >></p> <p>Maße und Toleranzen für Messläufe siehe Anhang CR 1.</p>		
		<p>Bemerkungen: 1) Kontrolle aus Sicherheitsgründen</p>	

C.I.P.	10 x 28 Ursprungsland: RU	TAB.	X
		Datum	12-05-30
		Revision	
	<p>PATRONE MAXI</p> <p>Längen</p> <p>L1 =</p> <p>L2 = 27.80</p> <p>L3 ¹⁾ = 27.80</p> <p>L4 =</p> <p>L5 =</p> <p>L6 ¹⁾ = 29.00</p> <p>Hülsenboden</p> <p>R = 1.25</p> <p>R1 = 10.00</p> <p>R3 =</p> <p>E = 3.21</p> <p>E1 = 8.55</p> <p>e min = 1.00</p> <p>δ = 37°</p> <p>f = 0.50</p> <p>β =</p> <p>Pulverkammer</p> <p>P1 = 10.00</p> <p>P2 =</p> <p>Schulterkonus</p> <p>α =</p> <p>S =</p> <p>r1 min =</p> <p>r2 =</p> <p>Hülsenhals</p> <p>H1 =</p> <p>H2 ¹⁾ = 9.55</p> <p>Geschoss</p> <p>G1 =</p> <p>G2 =</p> <p>F =</p> <p>L3+G = 42.39</p> <p>Drücke (Energien)</p> <p>Mech. elektr. Wandler</p> <p>Pmax = 1800 bar</p> <p>PK = 2070 bar</p> <p>PE = 2340 bar</p> <p>M = 10.50</p> <p>Verschiedene Daten</p> <p>Fe =</p> <p>delta L =</p>	<p>PATRONELAGER MINI</p> <p>Längen</p> <p>L1 =</p> <p>L2 =</p> <p>L3 ¹⁾ = 25.41</p> <p>Stoßboden</p> <p>R =</p> <p>R1 = 10.10</p> <p>R2 =</p> <p>R3 =</p> <p>r =</p> <p>Pulverkammer</p> <p>E =</p> <p>P1 ¹⁾ = 10.10</p> <p>P2 =</p> <p>Schulterkonus</p> <p>α =</p> <p>S =</p> <p>r1 max =</p> <p>r2 =</p> <p>Hülsenhals</p> <p>H1 =</p> <p>H2 ¹⁾ = 9.76</p> <p>Geschossübergang</p> <p>G1 = 8.50</p> <p>G = 14.59</p> <p>α1 = 40°</p> <p>h = 1.73</p> <p>s = 13.74</p> <p>i = 45°</p> <p>w =</p> <p>Lauf</p> <p>F = 6.80</p> <p>Z =</p> <p>Züge</p> <p>b =</p> <p>N =</p> <p>u =</p> <p>Q = 36.32 mm²</p>	
			<p>Maßstab 1.5:1</p>
<p>Maße in << mm >> Maße und Toleranzen für Messläufe siehe Anhang CR 1.</p>			

C.I.P.	10 x 31 Ursprungsland: RU	TAB.	X
		Datum	16-10-18
		Revision	
	PATRONE MAXI		PATRONENLAGER MINI
	Längen L1 = L2 = L3 ¹⁾ = 31.00 -0.25 L4 = L5 = L6 ¹⁾ = 29.80 Hülsenboden R = 1.50 R1 = 10.00 R3 = E = 3.20 E1 = 8.60 e min = 1.00 delta = 45° f = 0.50 beta = 45° Pulverkammer P1 = 10.00 P2 = Schulterkonus alpha = S = r1 min = r2 = Hülsenhals H1 = H2 ¹⁾ = 9.55 Geschoss G1 = G2 = F = L3+G ¹⁾ = Drücke (Energien) Mech. elektr. Wandler Pmax = 1800 bar PK = 2070 bar PE = 2340 bar M = 10.50 Verschiedene Daten Fe ¹⁾ = delta L =		Längen L1 = L2 = L3 ¹⁾ = 25.41 Stoßboden R = R1 = 10.10 R2 = R3 = r = Pulverkammer E = P1 ¹⁾ = 10.10 P2 = Schulterkonus alpha = S = r1 max = r2 = Hülsenhals H1 = H2 ¹⁾ = 9.76 Geschossübergang G1 ²⁾ * = 7.50 G = alpha1 = 65° h* = 1.77 s = i = w = Lauf F ²⁾ * = 7.50 Z = Züge b = N = u = Q = 44.18 mm ²
<p>Maßstab 1.69:1</p> <p>Maße in << mm >> Maße und Toleranzen für Messläufe siehe Anhang CR5.</p>	<p>Bemerkungen: 1) Kontrolle aus Sicherheitsgründen 2) Toleranz für Messlauf * Grundmaße</p>		

C.I.P.	11,6 SAFEGOM Ursprungsland: FR	TAB. X
		Datum 96-03-19
		Revision 99-04-20

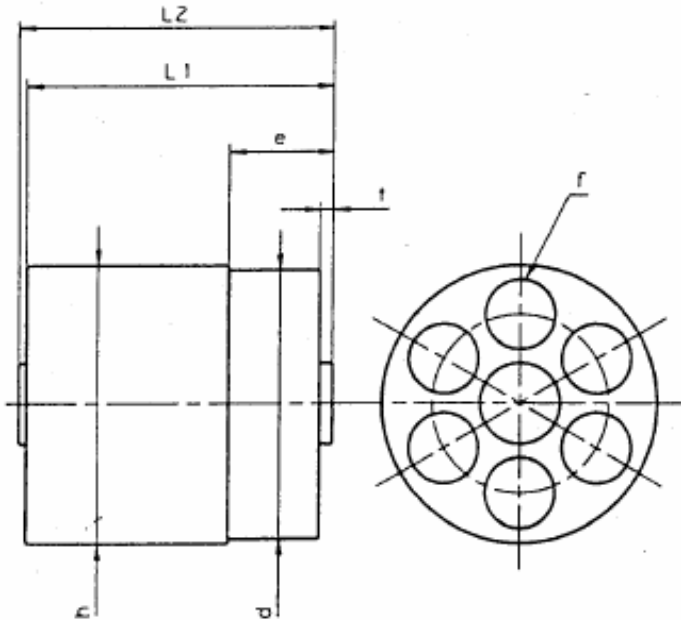

PATRONE MAXIMUM

Dimens. Wert Toler.

t	=	1.80	-0.10
e	=	14.20	-0.20
d	=	36.50	-0.10
h	=	37.80	-0.05
l1	=	41.55	-0.20
l2	=	42.55	-0.10
f	=	9.55	-0.05
Zellenzahl			6

PATRONENLAGER MINIMUM

Dimens. Wert Toler.

T	=	1.50	+0.05
D	=	38.20	+0.10
L1	=	41.70	+0.10
L2	=	42.60	+0.05
B	=	11.60	+0.03

Energie		
Emax	EK	EE
Joule		
35	40	45

Maßstab 1:1

Dimensionen in « mm »
 Dimensionen und Toleranzen für Messläufe:

Bemerkungen:

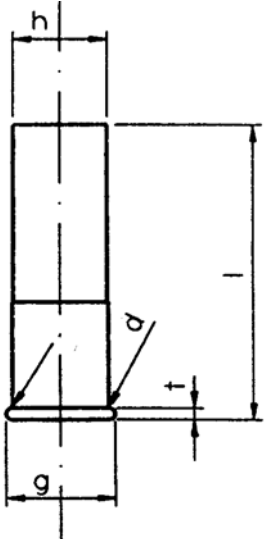
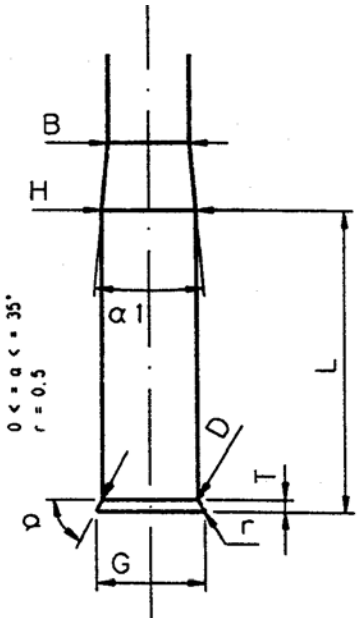
C.I.P.	12 mm x 39 Ursprungsland: FR		TAB.	X																				
			Datum	98-01-27																				
			Revision	98-06-09																				
			PATRONE MAXIMUM Dimens. Wert Toler. d ¹⁾ = 12.00 - 0.11 g = 13.60 - 0.40 t ¹⁾ = 1.55 - 0.35 h = 11.75 - 0.38 l = 39.00 - 2.50																					
						PATRONENLAGER MINIMUM Dimens. Wert Toler. D ¹⁾ = 12.05 + 0.10 G ¹⁾ = 13.70 + 0.10 T ¹⁾ = 1.55 + 0.10 H ¹⁾ = 11.80 + 0.10 B ¹⁾ = 10.20 + 0.50 alpha 1 ¹⁾ = 10°30' max L ¹⁾ = 39.00 + 2.00																		
Maßstab 1:1			<table border="0"> <tr> <td colspan="3"></td> <td colspan="2" style="text-align: center;">Energie</td> </tr> <tr> <td></td> <td style="text-align: center;">Emax</td> <td style="text-align: center;">EK</td> <td colspan="2" style="text-align: center;">EE</td> </tr> <tr> <td></td> <td colspan="2"></td> <td colspan="2" style="text-align: center;">Joule</td> </tr> <tr> <td></td> <td style="text-align: center;">100</td> <td style="text-align: center;">107</td> <td colspan="2" style="text-align: center;">110</td> </tr> </table>					Energie			Emax	EK	EE					Joule			100	107	110	
			Energie																					
	Emax	EK	EE																					
			Joule																					
	100	107	110																					
Dimensionen in « mm » Dimensionen und Toleranzen für Messläufe: Siehe Anhang CR 4.			Bemerkung: 1) Kontrolle aus Sicherheitsgründen																					

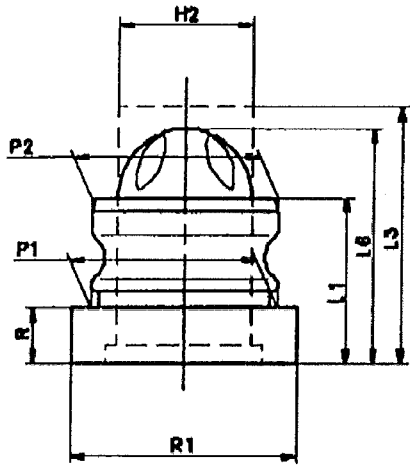
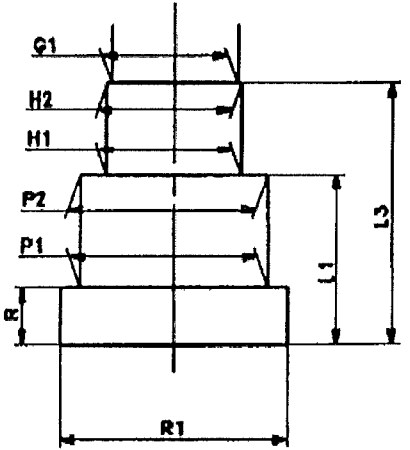
C.I.P.	14 mm Piexon Ursprungsland: DE	TAB.	X
		Datum	02-05-02
		Revision	04-09-27
	<p>PATRONE MAXI</p> <p>Längen</p> <p>L1 = 11.70 L2 = L3¹⁾ = 18.30 L4 = L5 = L6 = 16.50</p> <p>Hülsenboden</p> <p>R = 4.05 R1 = 16.25 R3 = E = E1 = e min = delta = f = beta =</p> <p>Pulverkammer</p> <p>P1 = 13.41 P2* = 13.41</p> <p>Schulterkonus</p> <p>alpha = S = r1 min = r2 =</p> <p>Hülsenhals</p> <p>H1* = H2¹⁾ = 9.58</p> <p>Geschoss</p> <p>G1 = G2 = G3 =</p> <p>Energie</p> <p>E_{max} = 190 Joule E_K = 203 Joule E_E = 209 Joule</p>	<p>PATRONENLAGER MINI</p> <p>Längen</p> <p>L1* = 11.80 L2 = L3¹⁾ = 18.50</p> <p>Stoßboden</p> <p>R = 4.05 R1 = 16.35 R2 = R3 = r =</p> <p>Pulverkammer</p> <p>E = P1¹⁾ = 13.43 P2* = 13.43</p> <p>Schulterkonus</p> <p>alpha = S = r1 max = r2 =</p> <p>Hülsenhals</p> <p>H1* = 9.60 H2¹⁾ = 9.60</p> <p>Übergang</p> <p>G1¹⁾* = 9.00 G = alpha1 = h = s = i = w =</p> <p>Lauf</p> <p>F¹⁾* = 9.00 Z =</p>	
			
Maßstab 2:1			
<p>Maße in « mm » Dimensionen und Toleranzen für Messläufe siehe Anhang CR 1</p>		<p>Bemerkungen: 1 Kontrolle aus Sicherheitsgründen * Grundmaße</p>	

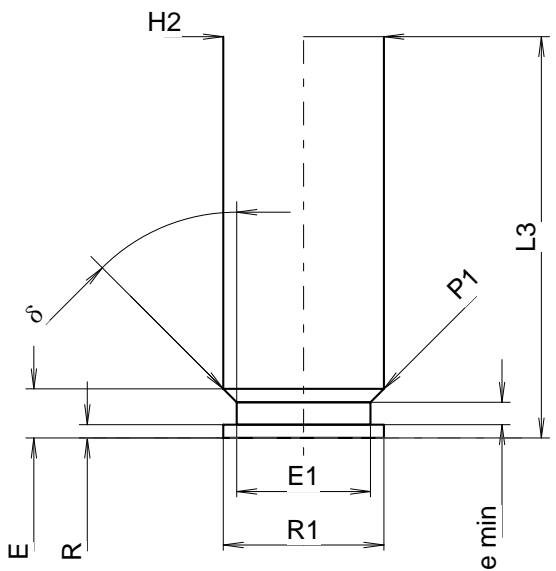
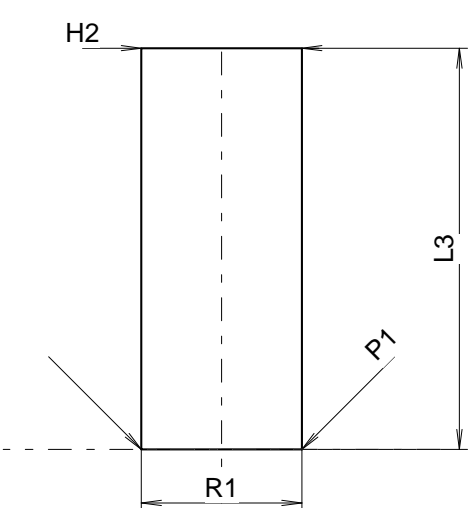
C.I.P.	18 x 45 Ursprungsland: RU	TAB.	X
		Datum	09-05-05
		Revision	
	<p>PATRONE MAXI</p> <p>Längen</p> <p>L1 =</p> <p>L2 =</p> <p>L3 ¹⁾ = 45.00</p> <p>L4 =</p> <p>L5 =</p> <p>L6 =</p> <p>Hülsenboden</p> <p>R = 1.50</p> <p>R1 = 18.00</p> <p>R3 =</p> <p>E = 5.50</p> <p>E1 = 15.00</p> <p>e min = 2.50</p> <p>delta = 45°</p> <p>f =</p> <p>beta =</p> <p>Pulverkammer</p> <p>P1 ¹⁾ = 18.00</p> <p>P2 =</p> <p>Schulterkonus</p> <p>alpha =</p> <p>S =</p> <p>r1 min =</p> <p>r2 =</p> <p>Hülsenhals</p> <p>H1 =</p> <p>H2 ¹⁾ = 18.00</p> <p>Geschoss</p> <p>G1 =</p> <p>G2 =</p> <p>F =</p> <p>L3+G =</p> <p>Drücke (Energien)</p> <p>Energie</p> <p>E_{max} = 79.0 Joule</p> <p>E_K = 85.0 Joule</p> <p>E_E = 87.0 Joule</p> <p>Verschiedene Daten</p> <p>Fe =</p> <p>delta L =</p>	<p>PATRONENLAGER MINI</p> <p>Längen</p> <p>L1 =</p> <p>L2 =</p> <p>L3 ²⁾ = 45.00 +0.39</p> <p>Stoßboden</p> <p>R =</p> <p>R1 = 18.00</p> <p>R2 =</p> <p>R3 =</p> <p>r =</p> <p>Pulverkammer</p> <p>E =</p> <p>P1 = 18.00</p> <p>P2 =</p> <p>Schulterkonus</p> <p>alpha =</p> <p>S =</p> <p>r1 max =</p> <p>r2 =</p> <p>Hülsenhals</p> <p>H1 =</p> <p>H2 ²⁾ = 18.00 +0.18</p> <p>Geschossübergang</p> <p>G1 =</p> <p>G =</p> <p>alpha1 =</p> <p>h =</p> <p>s =</p> <p>i =</p> <p>w =</p> <p>Lauf</p> <p>F =</p> <p>Z =</p> <p>Züge</p> <p>b =</p> <p>N =</p> <p>u =</p> <p>Q = mm²</p>	
			
<p>Maße in << mm >> Maße und Toleranzen für Messläufe siehe Anhang .</p>		<p>Bemerkungen: 1) Kontrolle aus Sicherheitsgründen 2) Toleranz für Messlauf</p>	

C.I.P.	18 x 81 Ursprungsland: CZ	TAB. X
		Datum 99-02-22
		Revision 00-06-07
	PATRONE MAXI	PATRONENLAGER MINI
	<p>Längen</p> <p>L1 = L2 = L3 ¹⁾ = 81.00 L4 = 148.50 L5 = L6 = 164.50</p> <p>Hülsenboden</p> <p>R = 2.00 R1 = 21.80 R3 = E = 6.24 E1 = 18.00 e min = 1.90 δ = 39°30'55" f = 0.80 β = 45°</p> <p>Pulverkammer</p> <p>P1 = 21.85 P2 =</p> <p>Schulterkonus</p> <p>α = S = r1 min = r2 =</p> <p>Hülsenhals</p> <p>H1 = H2 ¹⁾ = 19.10</p> <p>Geschoß</p> <p>G1 ¹⁾ = 16.30 G2 = 17.95 F = L3+G ¹⁾ = 82.85</p> <p>Drücke (Energien)</p> <p>Mechan. elektr. Wandler</p> <p>Pmax = 3550 bar PK = 4083 bar PE = 4615 bar M = 82.25</p> <p>Verschiedene Daten</p> <p>Fe = delta L =</p>	<p>Längen</p> <p>L1 = L2 = L3 ¹⁾ = 80.80</p> <p>Stossboden</p> <p>R = R1 = 21.95 R2 = R3 = r =</p> <p>Pulverkammer</p> <p>E = 6.24 P1 ¹⁾ = 21.95 P2 =</p> <p>Schulterkonus</p> <p>α = S = r1 max = r2 =</p> <p>Hülsenhals</p> <p>H1 = H2 ¹⁾ = 19.20</p> <p>Übergang</p> <p>G1 = G ^{1)*} = 1.85 α1 = h = s = i ¹⁾ = 17°58'09" w =</p> <p>Lauf</p> <p>F ^{1)*} = 18.00 Z =</p> <p>Züge</p> <p>b = N = u = Q = 254.47 mm²</p>
<p>Maßstab 1:2</p> <p>Maße in << mm >> Maße und Toleranzen für Messläufe siehe Anhang CR 1.</p>	<p>Bemerkungen: 1) Kontrolle aus Sicherheitsgründen * Grundmaße</p>	

C.I.P.	18,5 x 55 Ursprungsland: RU	TAB.	X
		Datum	09-05-05
		Revision	
	<p>PATRONE MAXI</p> <p>Längen</p> <p>L1 =</p> <p>L2 =</p> <p>L3 ¹⁾ = 55.00</p> <p>L4 =</p> <p>L5 =</p> <p>L6 =</p> <p>Hülsenboden</p> <p>R = 1.50</p> <p>R1 = 18.50</p> <p>R3 =</p> <p>E = 5.75</p> <p>E1 = 15.00</p> <p>e min = 2.50</p> <p>δ = 45°</p> <p>f =</p> <p>β =</p> <p>Pulverkammer</p> <p>P1 ¹⁾ = 18.50</p> <p>P2 =</p> <p>Schulterkonus</p> <p>α =</p> <p>S =</p> <p>r1 min =</p> <p>r2 =</p> <p>Hülsenhals</p> <p>H1 =</p> <p>H2 ¹⁾ = 18.50</p> <p>Geschoss</p> <p>G1 =</p> <p>G2 =</p> <p>F =</p> <p>L3+G =</p> <p>Drücke (Energien)</p> <p>Energie</p> <p>E_{max} = 93.0 Joule</p> <p>E_K = 100.0 Joule</p> <p>E_E = 102.0 Joule</p> <p>Verschiedene Daten</p> <p>Fe =</p> <p>delta L =</p>	<p>PATRONENLAGER MINI</p> <p>Längen</p> <p>L1 =</p> <p>L2 =</p> <p>L3 ²⁾ = 55.00 +0.46</p> <p>Stoßboden</p> <p>R =</p> <p>R1 = 18.50</p> <p>R2 =</p> <p>R3 =</p> <p>r =</p> <p>Pulverkammer</p> <p>E =</p> <p>P1 = 18.50</p> <p>P2 =</p> <p>Schulterkonus</p> <p>α =</p> <p>S =</p> <p>r1 max =</p> <p>r2 =</p> <p>Hülsenhals</p> <p>H1 =</p> <p>H2 ²⁾ = 18.50 +0.21</p> <p>Geschossübergang</p> <p>G1 =</p> <p>G =</p> <p>α₁ =</p> <p>h =</p> <p>s =</p> <p>i =</p> <p>w =</p> <p>Lauf</p> <p>F =</p> <p>Z =</p> <p>Züge</p> <p>b =</p> <p>N =</p> <p>u =</p> <p>Q = mm²</p>	
<p>Maße in << mm >> Maße und Toleranzen für Messläufe siehe Anhang .</p>		<p>Bemerkungen: 1) Kontrolle aus Sicherheitsgründen 2) Toleranz für Messlauf</p>	

C.I.P.	20 mm x 67,5 (6,3/14)	TAB.	X
		Datum	00-03-13
		Revision	02-05-15
Ursprungsland: DE			
	PATRONE MAXI	PATRONENLAGER MINI	
	<p>Längen</p> <p>L1 =</p> <p>L2 =</p> <p>L3 ¹⁾ = 67.50 -2.50</p> <p>L4 =</p> <p>L5 =</p> <p>L6 ¹⁾ = 65.00 -2.50</p> <p>Hülsenboden</p> <p>R ¹⁾ = 2.80 -0.20</p> <p>R1 ¹⁾ = 22.45 -0.20</p> <p>R3 =</p> <p>E =</p> <p>E1 =</p> <p>e min =</p> <p>δ =</p> <p>f =</p> <p>β =</p> <p>Pulverkammer</p> <p>P1 ¹⁾ = 20.60 -0.10</p> <p>P2 =</p> <p>Schulterkonus</p> <p>α =</p> <p>S =</p> <p>r1 min =</p> <p>r2 =</p> <p>Hülsenhals</p> <p>H1 =</p> <p>H2 ¹⁾ = 20.20 -0.25</p> <p>Geschoß</p> <p>G1 =</p> <p>G2 =</p> <p>F =</p> <p>L3+G =</p> <p>Drücke (Energien)</p> <p>Mechan. elektr. Wandler</p> <p>Pmax = 4300 bar</p> <p>PK = 4945 bar</p> <p>PE = 5590 bar</p> <p>M = 25.00</p> <p>Verschiedene Daten</p> <p>Fe =</p> <p>delta L =</p>	<p>Längen</p> <p>L1 =</p> <p>L2 =</p> <p>L3 ¹⁾ = 74.90</p> <p>Stossboden</p> <p>R ¹⁾ = 2.40 +0.10</p> <p>R1 ¹⁾ = 22.55 +0.10</p> <p>R2 =</p> <p>R3 =</p> <p>r =</p> <p>Pulverkammer</p> <p>E =</p> <p>P1 ¹⁾ = 20.65 +0.10</p> <p>P2 =</p> <p>Schulterkonus</p> <p>α =</p> <p>S =</p> <p>r1 max =</p> <p>r2 =</p> <p>Hülsenhals</p> <p>H1 =</p> <p>H2 ¹⁾ = 20.35 +0.10</p> <p>Übergang</p> <p>G1 =</p> <p>G =</p> <p>α1 = 180°</p> <p>h =</p> <p>s =</p> <p>i =</p> <p>w =</p> <p>Lauf</p> <p>F ^{1)*} = 12.00 +0.10</p> <p>Z =</p> <p>Züge</p> <p>b =</p> <p>N =</p> <p>u =</p> <p>Q = mm²</p>	
	Maßstab 1:1.5		
	<p>Maße in << mm >></p> <p>Maße und Toleranzen für Messläufe siehe Anhang CR 1.</p>		<p>Bemerkungen: 1) Kontrolle aus Sicherheitsgründen * Grundmaße</p>

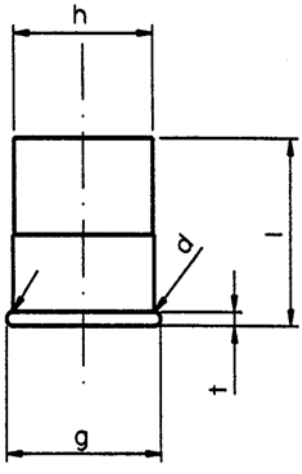
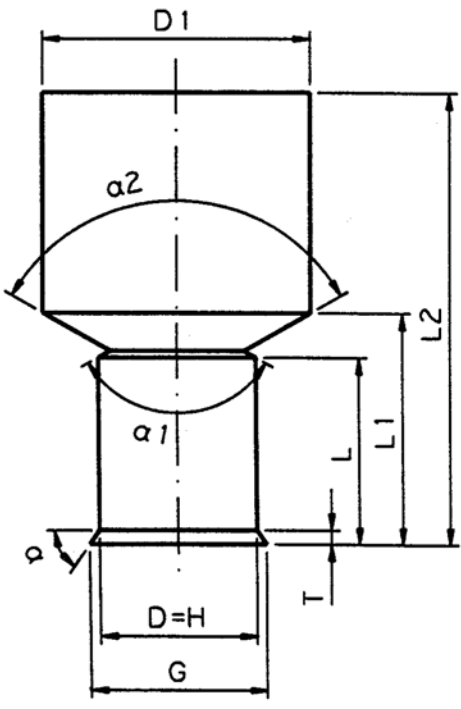
C.I.P.	MR 35 Punch Kal. 12-28,5 Ursprungsland: CZ	TAB.	X									
		Datum	96-03-19									
		Revision	98-06-09									
		<p>PATRONE MAXIMUM</p> <p>Dimens. Wert Toler.</p> <p>d¹⁾ = 20.60 - 0.15 g = 22.45 - 0.25 t¹⁾ = 1.88 - 0.25 h = 20.20 - 0.25 l = 25.00 - 2.50</p>										
		<p>PATRONENLAGER MINIMUM</p> <p>Dimens. Wert Toler.</p> <p>D¹⁾ = H = 20.20 H9 G¹⁾ = 23.07 T¹⁾ = 1.85 + 0.10 D1¹⁾ = 35.00 H11 B¹⁾ = 44.20 + 0.70 alpha¹⁾ = 55° alpha1¹⁾ = alpha2 = 120° L¹⁾ = 25.00 ± 0.10 L1¹⁾ = 31.00 ± 0.10 L2¹⁾ = 60.20 - 0.10</p> <p>Energie</p> <table border="1"> <tr> <td>E_{max}</td> <td>E_K</td> <td>E_E</td> </tr> <tr> <td>150</td> <td>160</td> <td>165</td> </tr> <tr> <td colspan="3" style="text-align: center;">Joule</td> </tr> </table>		E _{max}	E _K	E _E	150	160	165	Joule		
E _{max}	E _K	E _E										
150	160	165										
Joule												
<p>Maßstab 1:1</p>												
<p>Dimensionen in « mm » Dimensionen und Toleranzen für Messläufe:</p>		<p>Bemerkung : 1) Kontrolle aus Sicherheitsgründen</p>										

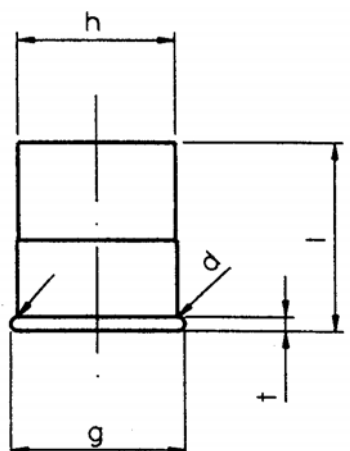
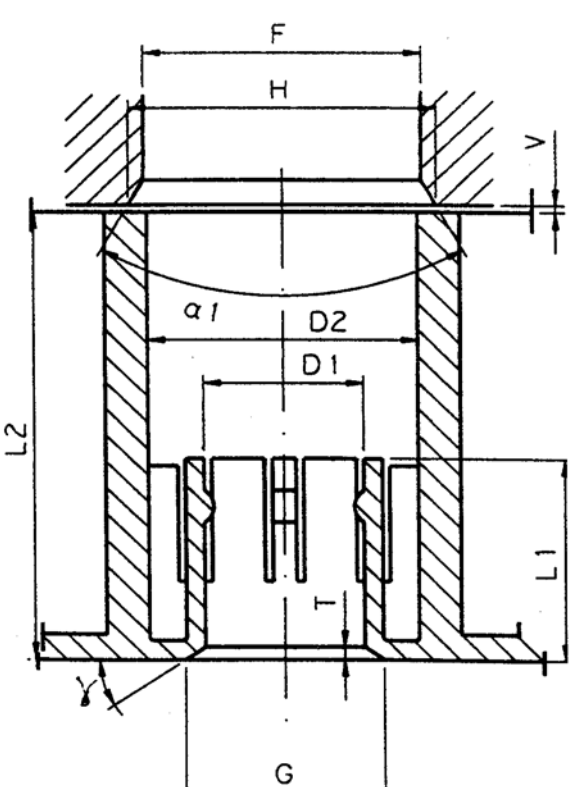
C.I.P.	MR 35 Punch Kal. 12-35 Ursprungsland : FR	TAB.	X						
		Datum	96-02-21						
		Revision	98-06-09						
		<p>PATRONE MAXIMUM</p> <p>Dimens. Wert Toler.</p> <p>$d^{1)}$ = 20.60 - 0.28 g = 22.45 - 0.48 $t^{1)}$ = 1.85 - 0.35 h = 20.20 - 0.47 l = 25.00 - 2.50</p>							
 <p>Maßstab 1:1</p>		<p>PATRONENLAGER MINIMUM</p> <p>Dimens. Wert Toler.</p> <p>$D1^{1)}$ = 20.60 $L1^{1)}$ = 27.00 $G\ mini^{1)}$ = 25.80 $T\ mini^{1)}$ = 1.70 $B^{1)}$ = $33^{\circ}10'42''$ $D2\ mini^{1)}$ = 35.00</p> <p>$L2^{1)}$ = 60.05 - 0.30 $V^{1)}$ = 0.95 - 0.70 $H^{1)}$ = $F\ mini^{1)}$ = 36.00 $\alpha^{1)}$ = 60°</p> <p>Energie</p> <table border="1"> <thead> <tr> <th>Emax</th> <th>EK</th> <th>EE</th> </tr> </thead> <tbody> <tr> <td>115</td> <td>125</td> <td>130</td> </tr> </tbody> </table>		Emax	EK	EE	115	125	130
Emax	EK	EE							
115	125	130							
<p>Dimensionen in « mm » Dimensionen und Toleranzen für Messläufe:</p>		<p>Bemerkung: 1) Kontrolle aus Sicherheitsgründen</p>							

C.I.P.	MR 35 Punch Kal. 15-35 Ursprungsland : FR	TAB.	X																																																			
		Datum	96-02-21																																																			
		Revision	98-06-09																																																			
		<p>PATRONE MAXIMUM</p> <p>Munition auswerfbar:</p> <p>wird beim Hersteller wiedergeladen und verwendet daher keine Hülse.</p>																																																				
		<p>PATRONENLAGER MINIMUM</p> <table border="1"> <thead> <tr> <th>Dimens.</th> <th>Wert</th> <th>Toler.</th> </tr> </thead> <tbody> <tr> <td>D1¹⁾</td> <td>= 15.00</td> <td></td> </tr> <tr> <td>L1¹⁾</td> <td>= 19.00</td> <td></td> </tr> <tr> <td>G¹⁾</td> <td>= 8.00</td> <td></td> </tr> <tr> <td>T</td> <td>= 0.95</td> <td>+0.10</td> </tr> <tr> <td>D3</td> <td>= 5.85</td> <td>+0.10</td> </tr> <tr> <td>L3</td> <td>= 6.50</td> <td></td> </tr> <tr> <td>D2 mini¹⁾</td> <td>= 35.00</td> <td></td> </tr> <tr> <td>L2¹⁾</td> <td>= 60.05</td> <td>- 0.30</td> </tr> <tr> <td>V¹⁾</td> <td>= 0.95</td> <td>- 0.70</td> </tr> <tr> <td>H¹⁾</td> <td>=</td> <td></td> </tr> <tr> <td>F mini¹⁾</td> <td>= 36.00</td> <td></td> </tr> <tr> <td>alpha¹⁾</td> <td>= 60°</td> <td></td> </tr> </tbody> </table> <table border="1"> <thead> <tr> <th colspan="3">Energie</th> </tr> <tr> <th>Emax</th> <th>EK</th> <th>EE</th> </tr> <tr> <th colspan="3">Joule</th> </tr> </thead> <tbody> <tr> <td>115</td> <td>125</td> <td>130</td> </tr> </tbody> </table>		Dimens.	Wert	Toler.	D1 ¹⁾	= 15.00		L1 ¹⁾	= 19.00		G ¹⁾	= 8.00		T	= 0.95	+0.10	D3	= 5.85	+0.10	L3	= 6.50		D2 mini ¹⁾	= 35.00		L2 ¹⁾	= 60.05	- 0.30	V ¹⁾	= 0.95	- 0.70	H ¹⁾	=		F mini ¹⁾	= 36.00		alpha ¹⁾	= 60°		Energie			Emax	EK	EE	Joule			115	125	130
Dimens.	Wert	Toler.																																																				
D1 ¹⁾	= 15.00																																																					
L1 ¹⁾	= 19.00																																																					
G ¹⁾	= 8.00																																																					
T	= 0.95	+0.10																																																				
D3	= 5.85	+0.10																																																				
L3	= 6.50																																																					
D2 mini ¹⁾	= 35.00																																																					
L2 ¹⁾	= 60.05	- 0.30																																																				
V ¹⁾	= 0.95	- 0.70																																																				
H ¹⁾	=																																																					
F mini ¹⁾	= 36.00																																																					
alpha ¹⁾	= 60°																																																					
Energie																																																						
Emax	EK	EE																																																				
Joule																																																						
115	125	130																																																				
<p>Maßstab 1 : 1</p>																																																						
<p>Dimensionen in « mm » Dimensionen und Toleranzen für Messläufe:</p>		<p>Bemerkung: 1) Kontrolle aus Sicherheitsgründen</p>																																																				

C.I.P.	366 TKM Ursprungsland: RU	TAB.	X
		Datum	16-05-18
		Revision	
	<p>PATRONE MAXI</p> <p>Längen</p> <p>L1 =</p> <p>L2 =</p> <p>L3 ¹⁾ = 37.50 -0.25</p> <p>L4 =</p> <p>L5 =</p> <p>L6 = 53.50</p> <p>Hülsenboden</p> <p>R = 1.50</p> <p>R1 = 11.35</p> <p>R3 =</p> <p>E = 3.20</p> <p>E1 = 9.56</p> <p>e min = 1.00</p> <p>δ = 51°58'12"</p> <p>f = 0.25</p> <p>β = 45°</p> <p>Pulverkammer</p> <p>P1 = 11.35</p> <p>P2 =</p> <p>Schulterkonus</p> <p>α =</p> <p>S =</p> <p>r1 min =</p> <p>r2 =</p> <p>Hülsenhals</p> <p>H1 =</p> <p>H2 ¹⁾ = 10.00</p> <p>Geschoss</p> <p>G1 ¹⁾ = 9.58</p> <p>G2 =</p> <p>F =</p> <p>L3+G ¹⁾ = 41.50</p> <p>Drücke (Energien)</p> <p>Mech. elektr. Wandler</p> <p>Pmax = 3300 bar</p> <p>PK = 3795 bar</p> <p>PE = 4290 bar</p> <p>M = 25.00</p> <p>Verschiedene Daten</p> <p>Fe ¹⁾⁶⁾ = 0.15</p> <p>delta L =</p>	<p>PATRONENLAGER MINI</p> <p>Längen</p> <p>L1 =</p> <p>L2 =</p> <p>L3 ¹⁾ = 37.55</p> <p>Stoßboden</p> <p>R =</p> <p>R1 = 11.38</p> <p>R2 =</p> <p>R3 =</p> <p>r =</p> <p>Pulverkammer</p> <p>E = 3.20</p> <p>P1 ¹⁾ = 11.37</p> <p>P2 =</p> <p>Schulterkonus</p> <p>α =</p> <p>S =</p> <p>r1 max =</p> <p>r2 =</p> <p>Hülsenhals</p> <p>H1 =</p> <p>H2 ¹⁾ = 10.02</p> <p>Geschossübergang</p> <p>G1 ¹⁾* = 9.65</p> <p>G ¹⁾ = 4.00</p> <p>α1 = 115°</p> <p>h* = 0.12</p> <p>s =</p> <p>i ¹⁾* = 0°44'18"</p> <p>w =</p> <p>Lauf</p> <p>F ¹⁾* = 9.55</p> <p>Z = 9.55</p> <p>Züge</p> <p>b =</p> <p>N =</p> <p>u =</p> <p>Q = 71.63 mm²</p>	
			<p>Maßstab 1.42:1</p> <p>Maße in << mm >> Maße und Toleranzen für Messläufe siehe Anhang CR 1.</p>

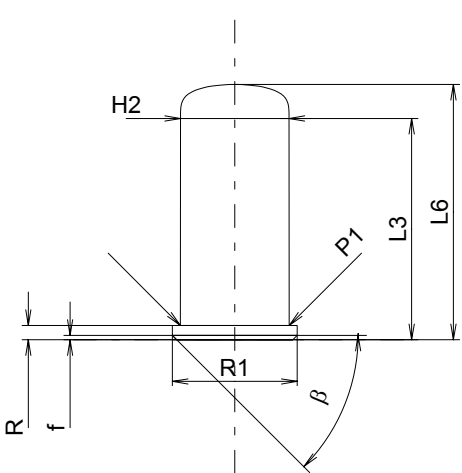
C.I.P.	380 Alfa		TAB.	X
	Ursprungsland: CZ		Datum	01-05-17
			Revision	02-05-15
	PATRONE MAXI		PATRONENLAGER MINI	
	Längen L1 = L2* = 19.40 L3 ¹⁾ = 19.50 L4 = L5 = L6 = 22.50 Hülsenboden R = 1.25 R1 = 11.00 R3 = E = E1 = e min = delta = f = 0.38 beta = 45° Pulverkammer P1 = 9.58 P2 = Schulterkonus alpha = S = r1 min = r2 = Hülsenhals H1 = H2 ¹⁾ = 9.57 Geschoss G1 = G2 = F = L3+G = Drücke (Energien) Mechan. elektr. Wandler Pmax = 300 bar PK = 345 bar PE = 390 bar M = 10.50 Verschiedene Daten Fe = delta L =		Längen L1 = L2 = L3 ¹⁾ = 19.50 Stoßboden R ¹⁾ = 1.35 R1 = 11.05 R2 = R3 = r = Pulverkammer E = P1 ¹⁾ = 9.60 P2 = Schulterkonus alpha = S = r1 max = r2 = Hülsenhals H1 = H2 ¹⁾ = 9.60 Übergang G1* = 8.00 G = alpha1 = 90° h* = 0.80 s = i = w = Lauf F ¹⁾ * = 8.00 Z ¹⁾ = 8.00 Züge b = N = u = Q = 50.27 mm ²	
Maßstab 1.5:1				
Maße in << mm >> Maße und Toleranzen für Messläufe siehe Anhang CR 1.		Bemerkungen: 1) Kontrolle aus Sicherheitsgründen * Grundmaße		

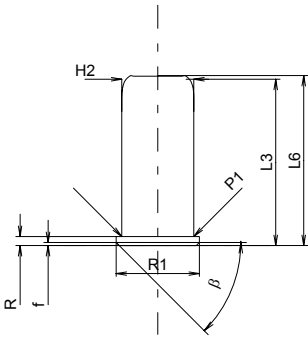
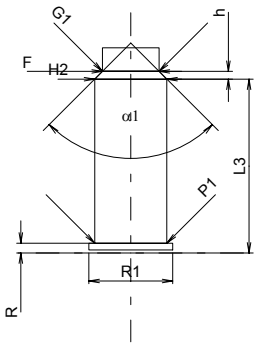
C.I.P.	380 ME Gum		TAB. X
	Ursprungsland: IT		Datum 99-08-04
			Revision 02-05-15
	PATRONE MAXI Längen L1 = L2 = 22.00 L3 = 22.00 L4 = L5 = L6 = 22.50 Hülsenboden R ¹⁾ = 1.20 -0.10 R1 = 11.00 R3 = E = E1 = e min = δ = f = 0.40 β = 45° Pulverkammer P1 = 9.50 P2 = Schulterkonus α = S = r1 min = r2 = Hülsenhals H1 = H2 ¹⁾ = 9.50 Geschoß G1 = G2 = F = L3+G = Drücke (Energien) Mechan. elektr. Wandler Pmax = 300 bar PK = 345 bar PE = 390 bar M = 10.50 Verschiedene Daten Fe = delta L =	PATRONE MINIMI Längen L1 = L2 = L3 ¹⁾ = 23.00 Stossboden R ¹⁾ = 1.30 R1 = 11.10 R2 = R3 = r = Pulverkammer E = P1 ¹⁾ = 9.55 P2 = Schulterkonus α = S = r1 max = r2 = Hülsenhals H1 = H2 ¹⁾ = 9.55 Übergang G1 ^{1)*} = 7.51 G = α1 = 90° h* = 1.02 s = i = w = Lauf F ^{1)*} = 7.50 Z = Züge b = N = u = Q = 44.18 mm ²	
			
Maßstab 1:1			
Maße in << mm >> Maße und Toleranzen für Messläufe siehe Anhang CR 1.	Bemerkungen: 1) Kontrolle aus Sicherheitsgründen * Grundmaße		

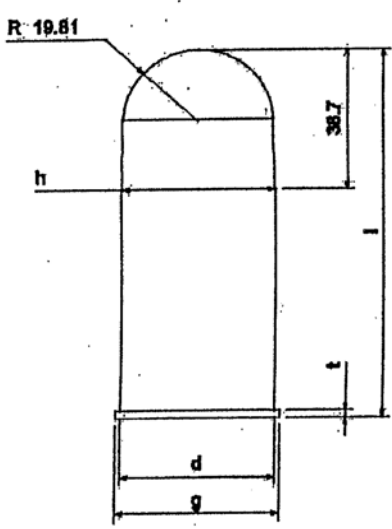
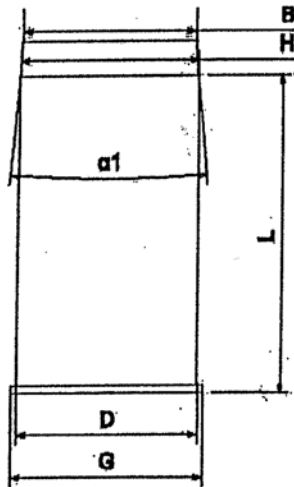
C.I.P.	40 x 46 Ursprungsland: US	TAB.	X																																																																				
		Date	07-05-14																																																																				
		Revision	08-04-15																																																																				
	PATRONE MAXIMUM																																																																						
	<table border="0"> <thead> <tr> <th></th> <th>Maxi</th> <th>Mini</th> <th></th> </tr> </thead> <tbody> <tr> <td>Culot</td> <td>dia. d = 41.15 mm</td> <td>40.90 mm</td> <td>(1)</td> </tr> <tr> <td>Bourrelet</td> <td>dia. g = 43.61 mm</td> <td>43.35 mm</td> <td></td> </tr> <tr> <td>Bourrelet</td> <td>ép. t = 1.93 mm</td> <td>1.77 mm</td> <td>(1)</td> </tr> <tr> <td>Tube</td> <td>dia. h = 40.51 mm</td> <td>40.26 mm</td> <td></td> </tr> <tr> <td colspan="4">Longueur :</td> </tr> <tr> <td>L maxi</td> <td colspan="2">= 110 mm</td> <td>Tolérance : -0.50 mm</td> </tr> </tbody> </table>		Maxi	Mini		Culot	dia. d = 41.15 mm	40.90 mm	(1)	Bourrelet	dia. g = 43.61 mm	43.35 mm		Bourrelet	ép. t = 1.93 mm	1.77 mm	(1)	Tube	dia. h = 40.51 mm	40.26 mm		Longueur :				L maxi	= 110 mm		Tolérance : -0.50 mm																																										
	Maxi	Mini																																																																					
Culot	dia. d = 41.15 mm	40.90 mm	(1)																																																																				
Bourrelet	dia. g = 43.61 mm	43.35 mm																																																																					
Bourrelet	ép. t = 1.93 mm	1.77 mm	(1)																																																																				
Tube	dia. h = 40.51 mm	40.26 mm																																																																					
Longueur :																																																																							
L maxi	= 110 mm		Tolérance : -0.50 mm																																																																				
	PATRONENLAGER MINIMUM																																																																						
	<table border="0"> <tbody> <tr> <td>Culot</td> <td>dia.</td> <td>D mini = 41.50 mm</td> <td>+ 0.1 mm</td> <td>(1)</td> </tr> <tr> <td>Drageoir</td> <td>dia.</td> <td>G mini = 44.20 mm</td> <td>+ 0.2 mm</td> <td></td> </tr> <tr> <td>Drageoir</td> <td>pro.</td> <td>T mini = 1.90 mm</td> <td>± 0.05 mm</td> <td>(1)</td> </tr> <tr> <td>Chambre</td> <td>dia.</td> <td>H mini = 41.30 mm</td> <td>± 0.05 mm</td> <td>(1)</td> </tr> <tr> <td>Canon</td> <td>dia.</td> <td>B mini = 40.86 mm</td> <td>+ 0.05 mm</td> <td>(1)</td> </tr> <tr> <td>Canon</td> <td>angle</td> <td>α1 mini = 10°</td> <td></td> <td>(1)</td> </tr> <tr> <td colspan="5">Longueur :</td> </tr> <tr> <td>I maxi</td> <td colspan="2">= 49.10 mm</td> <td>Tolérance : +0.50 mm</td> <td>(1)</td> </tr> <tr> <td>E max</td> <td colspan="4">= 160 Joules</td> </tr> <tr> <td>EK</td> <td colspan="4"></td> </tr> <tr> <td>EE</td> <td colspan="4">= 176 Joules</td> </tr> <tr> <td>Verschlussabstand</td> <td colspan="2">= 0.10 mm (canon manomètre)</td> <td></td> <td>(1)</td> </tr> <tr> <td></td> <td colspan="2">= 0.20 mm (basculant)</td> <td></td> <td>(1)</td> </tr> <tr> <td></td> <td colspan="2">= 0.35 mm (automatique)</td> <td></td> <td>(1)</td> </tr> </tbody> </table>	Culot	dia.	D mini = 41.50 mm	+ 0.1 mm	(1)	Drageoir	dia.	G mini = 44.20 mm	+ 0.2 mm		Drageoir	pro.	T mini = 1.90 mm	± 0.05 mm	(1)	Chambre	dia.	H mini = 41.30 mm	± 0.05 mm	(1)	Canon	dia.	B mini = 40.86 mm	+ 0.05 mm	(1)	Canon	angle	α1 mini = 10°		(1)	Longueur :					I maxi	= 49.10 mm		Tolérance : +0.50 mm	(1)	E max	= 160 Joules				EK					EE	= 176 Joules				Verschlussabstand	= 0.10 mm (canon manomètre)			(1)		= 0.20 mm (basculant)			(1)		= 0.35 mm (automatique)			(1)
Culot	dia.	D mini = 41.50 mm	+ 0.1 mm	(1)																																																																			
Drageoir	dia.	G mini = 44.20 mm	+ 0.2 mm																																																																				
Drageoir	pro.	T mini = 1.90 mm	± 0.05 mm	(1)																																																																			
Chambre	dia.	H mini = 41.30 mm	± 0.05 mm	(1)																																																																			
Canon	dia.	B mini = 40.86 mm	+ 0.05 mm	(1)																																																																			
Canon	angle	α1 mini = 10°		(1)																																																																			
Longueur :																																																																							
I maxi	= 49.10 mm		Tolérance : +0.50 mm	(1)																																																																			
E max	= 160 Joules																																																																						
EK																																																																							
EE	= 176 Joules																																																																						
Verschlussabstand	= 0.10 mm (canon manomètre)			(1)																																																																			
	= 0.20 mm (basculant)			(1)																																																																			
	= 0.35 mm (automatique)			(1)																																																																			
Dimensionen in « mm » Dimensionen und Toleranzen für Messläufe: Annexe CR4		Bemerkung: 1) Kontrolle aus Sicherheitsgründen																																																																					

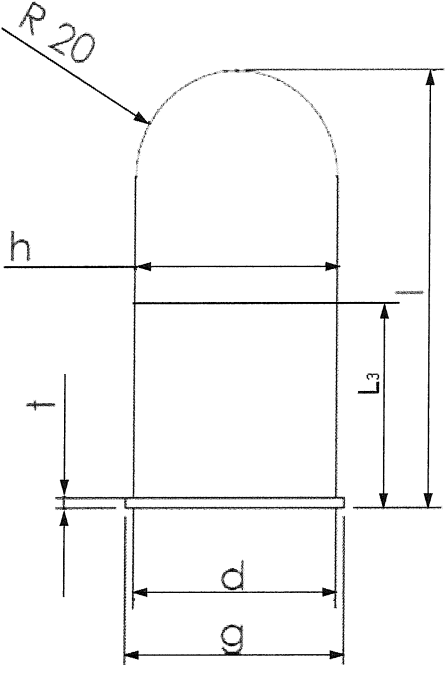
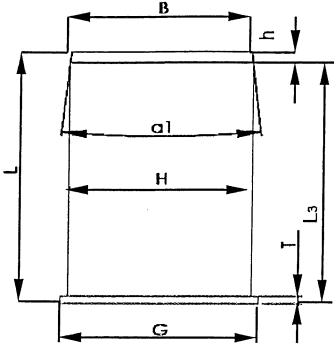
C.I.P.	40 x 46 BDLR X Pays d'origine: FR	TAB	X																																																																																																				
		Date	12-05-30																																																																																																				
		Révision																																																																																																					
	<p>CARTOUCHE MAXIMALE</p> <table border="0"> <thead> <tr> <th></th> <th style="text-align: center;">Maxi</th> <th style="text-align: center;">Mini</th> <th></th> </tr> </thead> <tbody> <tr> <td>Culot</td> <td>dia. d = 41.00</td> <td>40.90</td> <td>(1)</td> </tr> <tr> <td>Bourrelet</td> <td>dia. g = 43.70</td> <td>43.60</td> <td></td> </tr> <tr> <td>Bourrelet</td> <td>ép. t = 2.03</td> <td>1.91</td> <td>(1)</td> </tr> <tr> <td>Sabot</td> <td>dia. h = 41.35</td> <td>41.20</td> <td></td> </tr> <tr> <td colspan="4">Longueur :</td> </tr> <tr> <td>L3</td> <td>= 45.2</td> <td></td> <td></td> </tr> <tr> <td>l</td> <td>= 96.0</td> <td></td> <td></td> </tr> <tr> <td></td> <td></td> <td></td> <td style="text-align: right;">Tolérance : -2.0</td> </tr> </tbody> </table>				Maxi	Mini		Culot	dia. d = 41.00	40.90	(1)	Bourrelet	dia. g = 43.70	43.60		Bourrelet	ép. t = 2.03	1.91	(1)	Sabot	dia. h = 41.35	41.20		Longueur :				L3	= 45.2			l	= 96.0						Tolérance : -2.0																																																																
	Maxi	Mini																																																																																																					
Culot	dia. d = 41.00	40.90	(1)																																																																																																				
Bourrelet	dia. g = 43.70	43.60																																																																																																					
Bourrelet	ép. t = 2.03	1.91	(1)																																																																																																				
Sabot	dia. h = 41.35	41.20																																																																																																					
Longueur :																																																																																																							
L3	= 45.2																																																																																																						
l	= 96.0																																																																																																						
			Tolérance : -2.0																																																																																																				
	<p>CHAMBRE MINIMALE</p> <table border="0"> <tbody> <tr> <td>Drageoir</td> <td>dia.</td> <td>G mini = 44.05</td> <td>+ 0.05</td> <td></td> </tr> <tr> <td>Drageoir</td> <td>pro.</td> <td>T mini = 2.00</td> <td>+ 0.04</td> <td>(1)</td> </tr> <tr> <td>Chambre</td> <td>dia.</td> <td>H mini = 41.50</td> <td>+ 0.20</td> <td>(1)</td> </tr> <tr> <td>Canon</td> <td>dia.</td> <td>B mini = 40.80</td> <td>+ 0.04</td> <td>(1)</td> </tr> <tr> <td>Canon</td> <td>angle</td> <td>a1 mini = 10°</td> <td></td> <td></td> </tr> <tr> <td>Canon</td> <td></td> <td>N = 6 Rayures</td> <td></td> <td></td> </tr> <tr> <td>Canon</td> <td></td> <td>F = 40.8</td> <td></td> <td></td> </tr> <tr> <td>Canon</td> <td></td> <td>Z = 41.4</td> <td></td> <td></td> </tr> <tr> <td>Canon</td> <td></td> <td>b = 3.0</td> <td></td> <td></td> </tr> <tr> <td>Canon</td> <td></td> <td>u = 1200 mm / tour</td> <td></td> <td></td> </tr> <tr> <td colspan="5">Longueur :</td> </tr> <tr> <td>L3</td> <td></td> <td>= 46.5</td> <td></td> <td></td> </tr> <tr> <td>h</td> <td></td> <td>= 4.0</td> <td></td> <td></td> </tr> <tr> <td>L</td> <td></td> <td>= 50.5</td> <td></td> <td></td> </tr> <tr> <td></td> <td></td> <td></td> <td></td> <td style="text-align: right;">Tolérance : + 0.5 (1)</td> </tr> <tr> <td></td> <td></td> <td>L = L3 + h</td> <td></td> <td></td> </tr> <tr> <td>E max</td> <td></td> <td>= 200 Joules</td> <td></td> <td></td> </tr> <tr> <td>EE</td> <td></td> <td>= 220 Joules</td> <td></td> <td></td> </tr> <tr> <td>Feuillure</td> <td></td> <td>= 0,10 (canon manomètre)</td> <td></td> <td></td> </tr> <tr> <td></td> <td></td> <td>= 0,15 (basculant)</td> <td></td> <td></td> </tr> </tbody> </table>			Drageoir	dia.	G mini = 44.05	+ 0.05		Drageoir	pro.	T mini = 2.00	+ 0.04	(1)	Chambre	dia.	H mini = 41.50	+ 0.20	(1)	Canon	dia.	B mini = 40.80	+ 0.04	(1)	Canon	angle	a1 mini = 10°			Canon		N = 6 Rayures			Canon		F = 40.8			Canon		Z = 41.4			Canon		b = 3.0			Canon		u = 1200 mm / tour			Longueur :					L3		= 46.5			h		= 4.0			L		= 50.5							Tolérance : + 0.5 (1)			L = L3 + h			E max		= 200 Joules			EE		= 220 Joules			Feuillure		= 0,10 (canon manomètre)					= 0,15 (basculant)		
Drageoir	dia.	G mini = 44.05	+ 0.05																																																																																																				
Drageoir	pro.	T mini = 2.00	+ 0.04	(1)																																																																																																			
Chambre	dia.	H mini = 41.50	+ 0.20	(1)																																																																																																			
Canon	dia.	B mini = 40.80	+ 0.04	(1)																																																																																																			
Canon	angle	a1 mini = 10°																																																																																																					
Canon		N = 6 Rayures																																																																																																					
Canon		F = 40.8																																																																																																					
Canon		Z = 41.4																																																																																																					
Canon		b = 3.0																																																																																																					
Canon		u = 1200 mm / tour																																																																																																					
Longueur :																																																																																																							
L3		= 46.5																																																																																																					
h		= 4.0																																																																																																					
L		= 50.5																																																																																																					
				Tolérance : + 0.5 (1)																																																																																																			
		L = L3 + h																																																																																																					
E max		= 200 Joules																																																																																																					
EE		= 220 Joules																																																																																																					
Feuillure		= 0,10 (canon manomètre)																																																																																																					
		= 0,15 (basculant)																																																																																																					
<p>Dimensions en " mm "</p> <p>Dimensions et tolérances pour les canons d'épreuve :</p>		<p>Notes : (1) A contrôler pour la sécurité</p>																																																																																																					

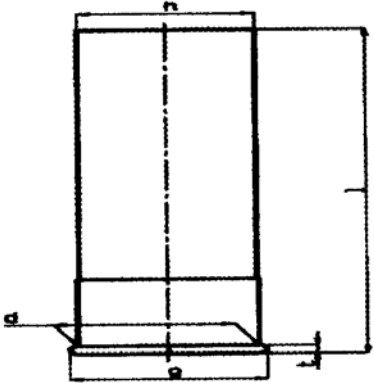
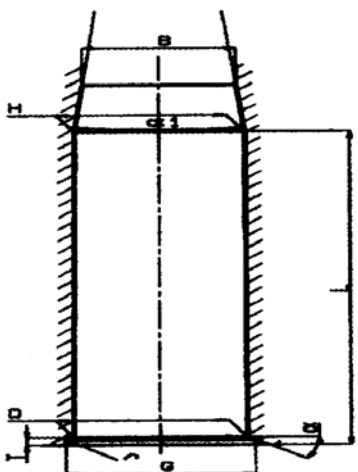
C.I.P.	44/83 Ursprungsland: FR	TAB.	X
		Datum	94-03-01
		Revision	94-06-01
		<p>PATRONE MAXIMUM</p> <p>Dimens. Wert Toler.</p> <p>d¹⁾ = 47.55 - 0.10 g = 51.50 - 0.15 t¹⁾ = 2.05 - 0.10 h = 47.05 - 0.10 l = 83.50 - 0.50</p>	
		<p>PATRONENLAGER MINIMUM</p> <p>Dimens. Wert Toler.</p> <p>D¹⁾ = 48.00 + 0.30 G = 51.50 + 0.50 T¹⁾ = 2.10 + 0.05 H¹⁾ = 47.80 + 0.30 B¹⁾ = 44.20 + 0.20 α¹⁾ = 22°04' max L¹⁾ = 83.50 + 0.50</p> <p>Energie Emax EK EE Joule</p> <p>Verschlussabstand</p> <p>Fe = 0.10 Messlauf Fe¹⁾ = 0.20 Mit Basküle Fe¹⁾ = 0.35 Automat</p>	
<p>Maßstab 1:2</p>			
<p>Dimensionen in « mm » Dimensionen und Toleranzen für Messläufe: Siehe Anhang CR 4.</p>		<p>Bemerkung : 1) Kontrolle aus Sicherheitsgründen</p>	

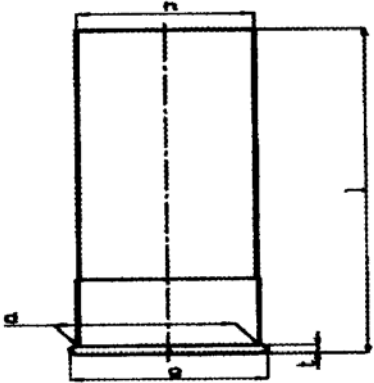
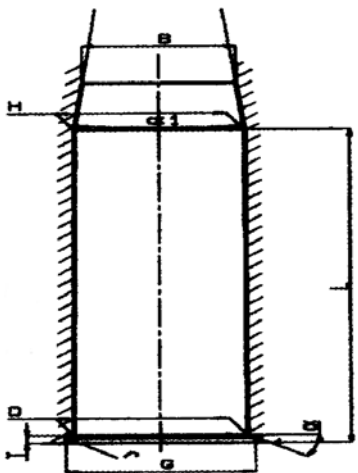
C.I.P.	44/83 SP Ursprungsland: FR	TAB.	X																									
		Datum	00-03-02																									
		Revision	02-05-15																									
		<p>PATRONE MAXIMUM</p> <p>Dimens. Wert Toler.</p> <p>d¹⁾ = 47.60 - 0.25 g = 51.35 - 0.45 t¹⁾ = 2.10 - 0.40 h = 47.60 - 0.45 l = 83.50 - 2.50</p>																										
				<p>PATRONENLAGER MINIMUM</p> <p>Dimens. Wert Toler.</p> <p>D¹⁾ = 47.70 + 0.10 G = 51.40 + 0.10 T¹⁾ = 2.25 + 0.10 H¹⁾ = 47.70 + 0.10 B¹⁾ = 44.20 + 0.70 alpha¹⁾ = 30° max L¹⁾ = 83.50 + 2.00</p> <table border="0"> <tr> <td></td> <td colspan="3">Energie</td> </tr> <tr> <td></td> <td>Emax</td> <td>EK</td> <td>EE</td> </tr> <tr> <td></td> <td></td> <td colspan="2">Joule</td> </tr> <tr> <td></td> <td>300</td> <td>321</td> <td>330</td> </tr> </table> <p>Verschlussabstand</p> <table border="0"> <tr> <td>Fe</td> <td>= 0.10</td> <td>Messlauf</td> </tr> <tr> <td>Fe¹⁾</td> <td>= 0.20</td> <td>Mit Basküle</td> </tr> <tr> <td>Fe¹⁾</td> <td>= 0.35</td> <td>Automat</td> </tr> </table>			Energie				Emax	EK	EE			Joule			300	321	330	Fe	= 0.10	Messlauf	Fe ¹⁾	= 0.20	Mit Basküle	Fe ¹⁾
	Energie																											
	Emax	EK	EE																									
		Joule																										
	300	321	330																									
Fe	= 0.10	Messlauf																										
Fe ¹⁾	= 0.20	Mit Basküle																										
Fe ¹⁾	= 0.35	Automat																										
<p>Maßstab 1:2</p>																												
<p>Dimensionen in « mm » Dimensionen und Toleranzen für Messläufe: Siehe Anhang CR 4.</p>		<p>Bemerkung: 1) Kontrolle aus Sicherheitsgründen</p>																										

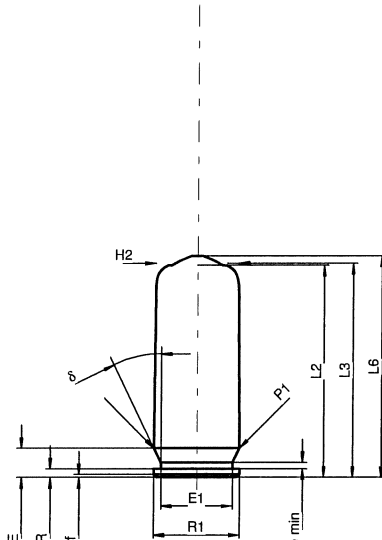
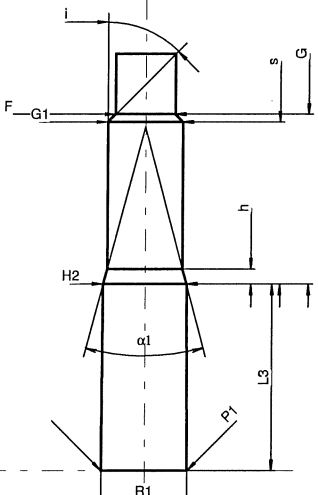
C.I.P.	45 x 30		TAB.	X
	Ursprungsland: RU		Datum	12-05-30
			Revision	
	PATRONE MAXI		PATRONENLAGER MINI	
	Längen L1 = L2 = 29.70 L3 ¹⁾ = 30.00 L4 = L5 = L6 ¹⁾ = 31.00 Hülsenboden R = 1.20 R1 = 12.15 R3 = E = 4.10 E1 = 10.15 e min = 0.90 delta = 26° f = 0.40 beta = Pulverkammer P1 = 12.10 P2 = Schulterkonus alpha = S = r1 min = r2 = Hülsenhals H1 = H2 ¹⁾ = 11.80 Geschoss G1 = G2 = F = L3+G = 53.86 Drücke (Energien) Mech. elektr. Wandler Pmax = 1300 bar PK = 1495 bar PE = 1690 bar M = 10.50 Verschiedene Daten Fe = delta L =		Längen L1 = L2 = L3 ¹⁾ = 26.15 Stoßboden R = R1 = 12.15 R2 = R3 = r = Pulverkammer E = P1 ¹⁾ = 12.15 P2 = Schulterkonus alpha = S = r1 max = r2 = Hülsenhals H1 = H2 ¹⁾ = 11.84 Geschossübergang G1 = 10.70 G = 23.86 alpha1 = 30° h = 2.13 s = 22.76 i = 45° w = Lauf F = 8.50 Z = Züge b = N = u = Q = 56.75 mm ²	
				
Maßstab 1:1				
Maße in << mm >> Maße und Toleranzen für Messläufe siehe Anhang CR 1.		Bemerkungen: 1) Kontrolle aus Sicherheitsgründen		

C.I.P.	45 Rubber Ursprungsland: RU	TAB. X
		Datum 09-05-05
		Revision
	PATRONE MAXI	PATRONENLAGER MINI
	<p>Längen</p> <p>L1 =</p> <p>L2 = 22.50</p> <p>L3 ¹⁾ = 22.81</p> <p>L4 =</p> <p>L5 =</p> <p>L6 ¹⁾ = 23.50</p> <p>Hülsenboden</p> <p>R = 1.24</p> <p>R1 = 12.19</p> <p>R3 =</p> <p>E = 4.11</p> <p>E1 = 10.16</p> <p>e min = 0.89</p> <p>δ = 26°</p> <p>f = 0.38</p> <p>β = 35°</p> <p>Pulverkammer</p> <p>P1 = 12.09</p> <p>P2 =</p> <p>Schulterkonus</p> <p>α =</p> <p>S =</p> <p>r1 min =</p> <p>r2 =</p> <p>Hülsenhals</p> <p>H1 =</p> <p>H2 ¹⁾ = 12.01</p> <p>Geschoss</p> <p>G1 =</p> <p>G2 =</p> <p>F =</p> <p>L3+G =</p> <p>Drücke (Energien)</p> <p>Mech. elektr. Wandler</p> <p>Pmax = 600 bar</p> <p>PK = 690 bar</p> <p>PE = 780 bar</p> <p>M = 12.50</p> <p>Verschiedene Daten</p> <p>Fe =</p> <p>delta L =</p>	<p>Längen</p> <p>L1 =</p> <p>L2 =</p> <p>L3 ¹⁾ = 19.97</p> <p>Stoßboden</p> <p>R =</p> <p>R1 = 12.21</p> <p>R2 =</p> <p>R3 =</p> <p>r =</p> <p>Pulverkammer</p> <p>E = 3.75</p> <p>P1 ¹⁾ = 12.18</p> <p>P2 =</p> <p>Schulterkonus</p> <p>α =</p> <p>S =</p> <p>r1 max =</p> <p>r2 =</p> <p>Hülsenhals</p> <p>H1 =</p> <p>H2 ¹⁾ = 12.03</p> <p>Geschossübergang</p> <p>G1 = 10.00</p> <p>G =</p> <p>α1 = 60°</p> <p>h = 1.76</p> <p>s =</p> <p>i =</p> <p>w =</p> <p>Lauf</p> <p>F = 10.00</p> <p>Z =</p> <p>Züge</p> <p>b =</p> <p>N =</p> <p>u =</p> <p>Q = 78.54 mm²</p>
<p>Maßstab 1:1</p> <p style="text-align: center;">Maße in << mm >> Maße und Toleranzen für Messläufe siehe Anhang CR 5.</p>	<p>Bemerkungen: 1) Kontrolle aus Sicherheitsgründen</p>	

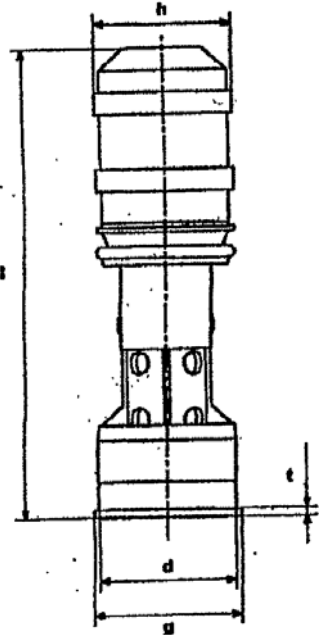
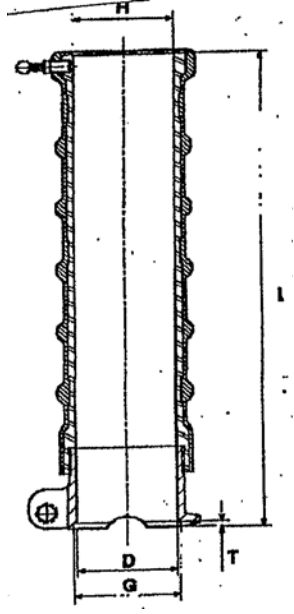
C.I.P.	56 Cougar Ursprungsland: FR	TAB.	X																	
		Date	07-05-14																	
		Révision																		
	PATRONE MAXIMUM																			
	<table border="1"> <thead> <tr> <th>Dimension</th> <th>Wert</th> <th>Toleranzen</th> </tr> </thead> <tbody> <tr> <td>g</td> <td>60</td> <td>-0,1</td> </tr> <tr> <td>d*</td> <td>56,3</td> <td>-0,3</td> </tr> <tr> <td>t*</td> <td>3,5</td> <td>-0,1</td> </tr> <tr> <td>l</td> <td>210,5</td> <td>-1,0</td> </tr> <tr> <td>h</td> <td>55,5</td> <td>-1,0</td> </tr> </tbody> </table>	Dimension	Wert	Toleranzen	g	60	-0,1	d*	56,3	-0,3	t*	3,5	-0,1	l	210,5	-1,0	h	55,5	-1,0	
Dimension	Wert	Toleranzen																		
g	60	-0,1																		
d*	56,3	-0,3																		
t*	3,5	-0,1																		
l	210,5	-1,0																		
h	55,5	-1,0																		
	PATRONENLAGER MINIMUM																			
	<table border="1"> <thead> <tr> <th>Dimension</th> <th>Wert</th> <th>Toleranzen</th> </tr> </thead> <tbody> <tr> <td>G*</td> <td>60</td> <td>+0,2</td> </tr> <tr> <td>D*</td> <td>56,8</td> <td>+0,1</td> </tr> <tr> <td>T*</td> <td>3,6</td> <td>+0,05</td> </tr> <tr> <td>L*</td> <td>291</td> <td>+2,0</td> </tr> <tr> <td>H*</td> <td>56,7</td> <td>+0,1</td> </tr> </tbody> </table>	Dimension	Wert	Toleranzen	G*	60	+0,2	D*	56,8	+0,1	T*	3,6	+0,05	L*	291	+2,0	H*	56,7	+0,1	
Dimension	Wert	Toleranzen																		
G*	60	+0,2																		
D*	56,8	+0,1																		
T*	3,6	+0,05																		
L*	291	+2,0																		
H*	56,7	+0,1																		
		<table border="1"> <thead> <tr> <th>Energie (Joules)</th> <th>E nominale</th> <th>E max (+10%)</th> </tr> </thead> <tbody> <tr> <td></td> <td>475</td> <td>500</td> </tr> </tbody> </table> <p>Verschussabstand Fe = 0,15 max (manomètre à bascule automatique)</p>		Energie (Joules)	E nominale	E max (+10%)		475	500											
Energie (Joules)	E nominale	E max (+10%)																		
	475	500																		
Dimensionen in « mm » Dimensionen und Toleranzen für Messläufe : Annexe CR4		Bemerkung : 1) Kontrolle aus Sicherheitsgründen																		

